

300-S

ALTO-SHAAM

Low-Temperature Hot-Food Holding Cabinet

CE

Keeping food that has been cooked to perfection hot and fresh until the moment it is served demands the gentle precision of Alto-Shaam's exclusive Halo Heat® technology. With controlled temperatures and a closed environment free from forced air, harsh heating elements, and added humidity, food is kept warm and flavorful, just as intended.

Standard features

- Simple and intuitive pushbutton control that commands all appliance functions with easily identifiable icons
- Halo Heat—a controlled, uniform heat source that gently surrounds food for better appearance, taste, and longer holding life
- Stainless steel interior resists corrosion
- Digital control senses temperature drops faster, providing quick heat recovery time
- Close temperature tolerance and even heat application maintain ideal serving temperature throughout the cabinet
- Antimicrobial handle retards the growth of illness-causing pathogens
- Door venting holds crispy food better



300-S



TEMPERATURE

Temperature range: 16°C to 93°C



CAPACITY

- 3** Three full-size or GN 1/1 pans 65mm deep, six half-size pans 65mm deep
 - 2** Two full-size or GN 1/1 pans 100mm deep, four half-size pans 100mm deep
 - 2** Two side racks with five pan positions spaced on 38mm centers
- 16 kg product maximum
28,5 L volume maximum

Configurations (select one)

Door swing

- Right hinged, standard
- Left hinged, optional

Electrical

- 230V, 1 ph

Cord and Plug Options

- CEE 7/7
- CH2-16p
- BS 1363 (U.K. only)

Accessories (select all that apply)

- Carving holder, prime rib (HL-2635)
- Drip pan without drain (PN-2122)
- Shelf, chrome wire (SH-2107)

Additional Features

- Stackable design—300-S Hot Holding Cabinet can be stacked with an identical cabinet or 300-TH/III Cook & Hold



300-S

DIMENSIONS

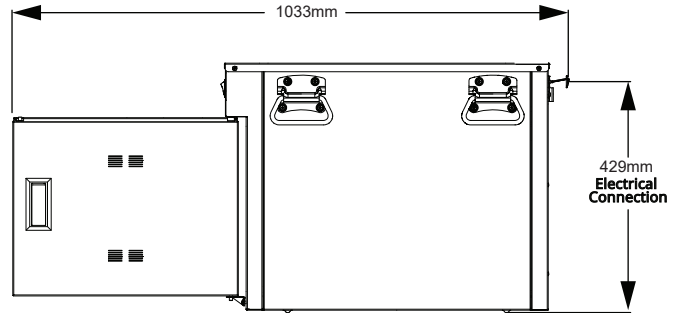
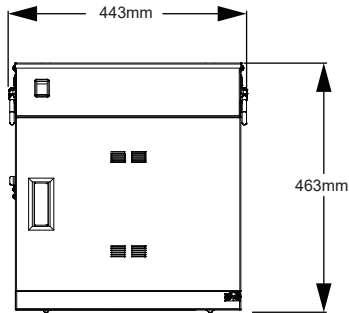
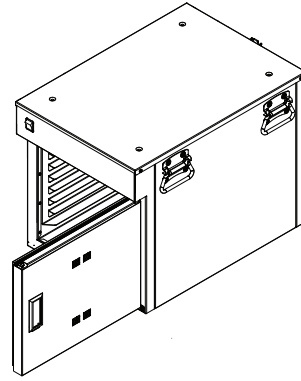
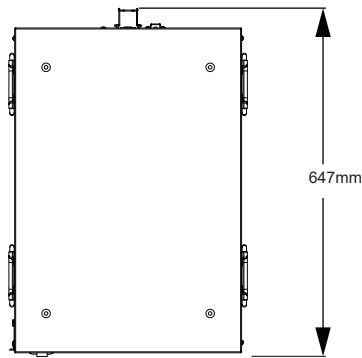

DIMENSIONS

Model	Exterior (H x W x D)	Interior (H x W x D)		
300-S	466mm x 443mm x 645mm	305mm x 348mm x 546mm		
	Ship Dimensions (L x W x H)*	Ship Weight*	Net Weight	
300-S	914mm x 610mm x 711mm	57 kg	29 kg	

*Domestic ground shipping information. Contact factory for export weight and dimensions.



REQUIREMENTS

- Appliance must be installed level.
- Appliance must not be installed in any area where it may be affected by steam, grease, dripping water, extreme temperatures, or any other severely adverse conditions.
- Appliances with casters and no cord or plug must be secured to the building structure with a flexible connector. Not factory supplied.



CLEARANCE

- Top: 51mm
- Left: 25mm
- Right: 25mm
- Back: 76mm



ELECTRIC

300-S	V	Ph	Hz	A	kW	Cord & Plug
230V	230	1	50/60	3.9	.80	CEE 7/7 Plug rated 250V CH2-16p Plug rated 250V BS 1363 (U.K. only) Plug rated 250V



HEAT

Heat of rejection		
300-S	Heat Gain qs, BTU/hr	Heat Gain qs, kW
	162	0.05

CONTACT US

W164 N9221 Water Street | Menomonee Falls, Wisconsin 53051 | U.S.A.
 Phone: 262.251.3800 | 800.558.8744 U.S.A./Canada | Fax: 262.251.7067 | alto-shaam.com