



CS-200 with Breath Guard



CS-100 with Breath Guard

### Models:

**CS-100**

**CS-200**

- **Installation**
- **Operation**
- **Maintenance**

W164 N9221 Water Street • P.O. Box 450  
Menomonee Falls, Wisconsin 53052-0450 U.S.A.

PHONE: 262.251.3800 • 800.558.8744 U.S.A. / CANADA  
FAX: 262.251.7067 • 800.329.8744 U.S.A. ONLY  
[www.alto-shaam.com](http://www.alto-shaam.com)



Consult instructions  
for operation and use.



## Manufacturer's Information

### Copyright

© Copyright 07/25 by Alto-Shaam, Inc.

All rights reserved.

This manual or any portion thereof may not be reproduced or used in any manner whatsoever without the express written permission of Alto-Shaam, Inc.

### Trademarks

All trademarks referenced in this documentation are the property of their respective owners.

### Manufacturer

Alto-Shaam, Inc.

P.O. Box 450

W164 N9221 Water Street

Menomonee Falls, WI 53052

### Original Instructions

The content in this manual is written in American English.

Warranty and Service Information ..... 4  
Delivery ..... 5  
Unpacking ..... 6  
Safety Procedures ..... 7  
Labels ..... 9  
Installation ..... 10  
Electrical Connection ..... 12  
Operation ..... 13  
Cleaning and Preventative Maintenance ..... 14  
Wire Diagrams ..... 15  
Warranty ..... 16

## Warranty and Service Information

---

### Extend Your Manufacturer's Warranty

---

**Register**

Register your Alto-Shaam appliance online, and you will automatically be entered into a monthly drawing to win an additional year extended warranty! Registering your appliance ensures prompt service in the event of a warranty claim.

Your personal information will not be shared with any other company.

[www.alto-shaam.com/warranty](http://www.alto-shaam.com/warranty)

### Alto-Shaam 24/7 Emergency Repair Service

---

**Call**

Call 800-558-8744 to reach our 24-hour emergency service call center for immediate access to local authorized service agencies outside standard business hours. The emergency service access is provided exclusively for Alto-Shaam equipment and is available throughout the United States through Alto-Shaam's toll free number.

**Availability**

Emergency service access is available seven days a week, including holidays.

This Alto-Shaam appliance has been thoroughly tested and inspected to ensure only the highest quality appliance is provided. Upon receipt, check for any possible shipping damage and report it at once to the delivering carrier.

This appliance, including unattached items and accessories, may be delivered in one or more packages. Ensure all standard items and options have been received with each appliance as ordered. Save all the information included with the appliance. Register the appliance online at [www.alto-shaam.com/en/customer-support/warranty-registration](http://www.alto-shaam.com/en/customer-support/warranty-registration) to ensure prompt service in the event of a warranty parts and labor claim.

This manual must be read and understood by all people using or installing the appliance. Contact the Alto-Shaam Tech Team Service Department if you have any questions concerning installation, operation, or maintenance.

1-800-558-8744; servicedept@alto-shaam.com

**The serial number is required for all inquiries.**

Always include both model and serial number(s) in any correspondence regarding the appliance.

**Model:** \_\_\_\_\_

**Serial number:** \_\_\_\_\_

**Purchased from:** \_\_\_\_\_

**Date installed:** \_\_\_\_\_ **Voltage:** \_\_\_\_\_



**CAUTION**



Appliance and accessories may be heavy. To prevent serious injury, **always** use a sufficient number of trained and experienced workers when moving or leveling appliance and handling accessories.

**Environmental Conditions**

Operational Environmental Conditions

- Before use, appliance must acclimate to room temperature in the environment it is placed — 24 hours is recommended.
- Ambient temperature range of 60°F to 110°F (16°C to 43°C).
- Relative humidity of less than 95% non-condensation.

## Unpacking

---

- Carefully remove the appliance from the carton or crate.

**NOTE:** Do not discard the carton and other packaging material until you have inspected the appliance for hidden damage and tested it for proper operation.

Do not discard this manual. This manual is considered to be part of the appliance and is to be provided to the owner or manager of the business or to the person responsible for training operators. Additional manuals are available from the manufacturer.

- Read all instructions in this manual carefully before installing this appliance, using the appliance or performing routine maintenance. Following procedures other than those indicated in this guide to use and clean the appliance is considered inappropriate and may cause damage, injury or fatal accidents, in addition to voiding the warranty and relieving Alto-Shaam of all liability.
- Remove all protective plastic film, packaging materials, and accessories from the appliance before connecting electrical power. Store any accessories in a convenient place for future use.

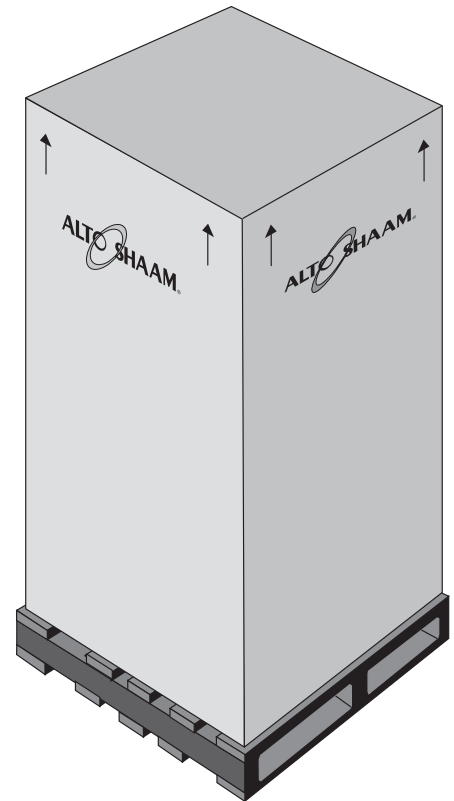

- The appliance is intended to hold hot food while carving. Only carve food meant for human consumption. No other use for this appliance is authorized and is therefore considered hazardous. The appliance must not be used to cook food containing flammable materials (such as food with alcohol). Substances with a low flash point can ignite spontaneously and cause a fire.
- The appliance is intended for use in commercial establishments where all operators are familiar with the purpose, limitations, and associated hazards of this appliance. Operating instructions and warnings must be read and understood by all operators and users. Alto-Shaam recommends regular staff training to avoid the risk of accident or damage to the appliance. Operators must also receive regular safety instructions.
- This appliance is intended to be used for commercial applications, for example in kitchens of restaurants, canteens, hospitals and in commercial enterprises such as bakeries, butcheries, etc., but not for continuous mass production of food.
- This appliance is not intended to be used by laymen in household and similar applications such as: staff kitchen areas in shops, offices, and other working environments; farmhouses, hotels, motels and other residential type environments; bed and breakfast type environments.
- Any troubleshooting guides, component views, and parts lists included in this manual are for general reference only and are intended for use by qualified and trained technicians.
- This manual should be considered a permanent part of this appliance. This manual and all supplied instructions, diagrams, schematics, parts lists, notices, and labels must remain with the appliance if the item is sold or moved to another location.

Knowledge of proper procedures is essential to the safe operation of electrically and/or gas energized equipment. The following signal words and symbols may be used throughout this manual.

## DANGER

Indicates a hazardous situation that, if not avoided, will result in death or serious injury.

## WARNING

Indicates a hazardous situation that, if not avoided, could result in death or serious injury.

## CAUTION

Indicates a hazardous situation that, if not avoided, could result in minor or moderate injury.

**NOTICE:** Indicates information considered important, but not hazard-related (e.g., messages relating to property damage).

**NOTICE:** For equipment delivered for use in any location regulated by the following directive: 2012/19/EC WEEE



**Do not** dispose of electrical or electronic equipment with other municipal waste.

## Safety Procedures

- To prevent serious injury, death or property damage, the appliance should be inspected and serviced at least every twelve (12) months by an authorized service partner or trained technician.
- **Only** allow an authorized service partner or trained technician to service or to repair the appliance. Installation or repairs that are not performed by an authorized service partner or trained technician, or the use of non-factory authorized parts will void the warranty and relieve Alto-Shaam of all liability.
- When working on this appliance, observe precautions in the literature, on tags, on labels attached to or shipped with the appliance, and other safety precautions that may apply.



### WARNING



This appliance must not be used by persons (including children) with reduced physical, sensory or mental capabilities, or lack of experience and knowledge, unless they have been given supervision concerning use of the appliance by person responsible for their safety.

Children should be supervised to ensure that they do not play with the appliance.



Children shall neither clean nor maintain the appliance.



### WARNING



This appliance shall not be installed where the public has access.

	<p>WARNING Electric shock hazard</p>
	<p>Made in U.S.A.</p>

## Installation

### WARNING

Improper installation, alteration, adjustment, service, cleaning, or maintenance could result in property damage, severe injury, or death.

Read and understand the installation, operating and maintenance instructions thoroughly before installing, servicing, or operating this equipment.

### CAUTION



To prevent **personal injury** or **property damage**:

**Always** use hand protection when operating this appliance to avoid burns. Metal parts of this equipment become hot when in operation.

### CAUTION



Appliance and accessories may be heavy. To prevent injury, **always** use a sufficient number of trained and experienced workers when moving or leveling appliance and handling accessories.

### WARNING

Food contamination and cutting hazard.

The heat lamp used in this appliance is coated to resist shattering. A shattered heat lamp could cause personal injury and contaminate the food being served in this appliance.

Use only Alto-Shaam coated heat lamps that meet or exceed the National Sanitation Foundation (NSF) standards in this appliance.

1. The appliance, complete with unattached items and accessories, may be delivered in one or more packages. Check to ensure all accessories ordered have been received.
2. The hot food holding carving station is designed to be mounted directly on top of a Halo Heat® Cook & Hold oven or holding cabinet. The carving station can also be used as a free-standing unit.  
 Heated cabinet mounted carving stations:  
 Remove the 1" (25mm) legs prior to placing the carving station on top of the Halo Heat Cook & Hold oven or holding cabinet. Appliance must be installed on a stable and level surface.  
 Free-standing carving stations:  
 Ensure that the 1" (25mm) legs are in place prior to placing the carving station on a work surface. Failure to operate the carving station without the 1" (25mm) legs prior to heating the carving station could result in damage to the surface on which the carving station is placed, may pose a potential fire hazard, and nullifies the validity of the UL listing mark. The appliance must be installed on a stable and level surface.
3. Do not install this appliance in any area where it may be affected by any adverse conditions such as steam, grease, dripping water, or high temperatures.
4. Do not install the carving station near any cold air source, freezer, air conditioning vents, or in any area where outside air temperature fluctuation can affect performance.
5. This appliance must be kept free and clear of any obstructions blocking access for maintenance or service.
6. Lift the Breath Guard up and slide into place in brackets found in the front of the appliance.  
 A number of adjustments are associated with initial installation and start-up. Installation and start-up adjustments are the responsibility of the dealer or user. These adjustments include but are not limited to leveling, electrical hook-up and installation of lamps.

### Leveling

Level the appliance from side-to-side and front-to-back with the use of a spirit (bubble) level.

**NOTICE:** Failure to properly level this appliance can cause improper function.

See Specification Sheet for dimensions and electrical connections.

CS-100	
CS-200	

### CS-100

<b>Heated product capacity</b>	
Weight, maximum	40 lbs (18 kg)
Meat size	Small steamship round

### CS-200

<b>Heated product capacity</b>	
Weight, maximum	70 lbs (31.7 kg)
Meat size	Large steamship round

# Electrical Connection

**! WARNING**

 To prevent **SERIOUS INJURY, DEATH or PROPERTY DAMAGE:**

All electrical connections must be made by a qualified and trained service technician in accordance with applicable electrical codes.

**! CAUTION**

 Power source must match voltage identified on appliance rating tag. The rating tag provides essential technical information required for any appliance installation, maintenance or repairs. Do not remove, damage or modify the rating tag.

**! WARNING**

Improper installation, alteration, adjustment, service, cleaning, or maintenance could result in property damage, severe injury, or death.

Read and understand the installation, operating and maintenance instructions thoroughly before installing, servicing, or operating this equipment.

1. An identification tag is permanently mounted on the carving station.
2. If necessary, a proper receptacle or outlet configuration as required for this unit, must be installed by a licensed electrician in accordance with applicable, local electrical codes.
3. If a power cord is used for the connection of the product an oil resistant cord like H05RN or H07RN or equivalent must be used.
4. Ground fault or residual current Type B protection device must accommodate a leakage current of 30mA.
5. Plug carving station into a properly grounded receptacle **only**, positioning the unit so the power supply cord is easily accessible in case of an emergency. Arcing will occur when connecting or disconnecting the unit unless all switches are in the Off (O) position.

**NOTICE:** Where local codes and CE regulatory requirements apply, appliances must be connected to an electrical circuit that is protected by an external GFCI outlet.





**! WARNING**





 To prevent serious injury, death, or property damage:

All electrical connections must be made by a qualified and trained service technician in accordance with applicable electrical codes.

 This appliance must be adequately grounded in accordance with local electrical codes or, in the absence of local codes, with the current edition of the National Electrical Code ANSI/NFPA No. 70. In Canada, all electrical connections are to be made in accordance with CSA C22.1, Canadian Electrical Code Part 1 or local codes.

 CE-approved appliances include an equipotential-bonding terminal marked with the symbol shown on the left. Provisions for earthing are to be made in accordance with IEC:2010 60335-1 section 27 or local codes.

Electrical - CS-100							
V	Ph	Hz	A	kW			
120	1	60	4.2	0.5	 NEMA 5-15P 15A - 120V PLUG		
230	1	50/60	2.2	0.5	PLUGS RATED 250V		
	CEE 7/7		CH2-16P		BS 1363		AS/NZS 3112

Electrical - CS-200							
V	PH	Hz	A	kW			
120	1	60	6.3	0.75	 NEMA 5-15P 15A - 120V PLUG		
230	1	50/60	3.26	0.75	PLUGS RATED 250V		
	CEE 7/7		CH2-16P		BS 1363		AS/NZS 3112

Wire diagrams are located on the bottom of the unit.

**⚠ WARNING**

Electric shock hazard.

Perform lockout/tagout procedures before cleaning or servicing this appliance.

Before initial use or after removing the appliance from storage:

1. Remove all packing material from the appliance.
2. Remove and wash any detachable items such as the cutting board and breath guard with hot, soapy water. Dry with a clean, damp lint-free cloth.
3. Remove all visible grease or oil from the appliance.
4. Clean the exterior of the appliance with a mild soap and water solution. Apply the solution with a clean, damp cloth. Do not use commercial or household cleaners that contain ammonia. Wipe with a clean, damp cloth to remove all detergent residue. Dry with a clean, lint-free cloth.
5. Clean the appliance glass with glass cleaner or distilled vinegar.
6. Install cutting board (a) and breath guard (b).

**NOTICE:** Do not use knives or utensils on the heated metal surface. Install cutting board before using.

The appliance is now ready for operation.

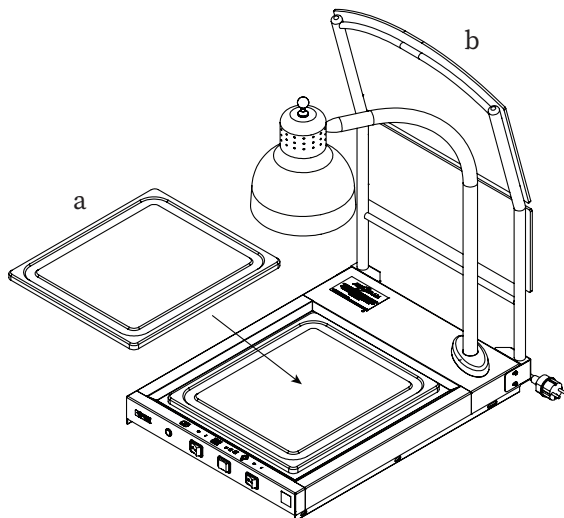

## Operating procedures

### 1. Set rocker switches

Set rocker switch for heated surface to the On (I) position. Set 3-way rocker switch to the desired holding temperature (low/medium/high). Set rocker switch for the lamp(s) to the On (I) position.

### 2. Preheat the carving station

Preheat the carving station for a minimum of 30 minutes.

### 3. Transfer hot foods to the carving station

The hot food product must be at the proper internal temperature before transferring food to the cutting board. Use a thermometer to check the internal temperature of the food being held. Adjust the carving station temperature to give the best overall setting based on the internal product temperature. If any food product is not at the proper serving temperature, use an Alto-Shaam oven to bring the product within the correct temperature range.

### 4. Check food temperature

Since proper temperature range depends on the type of products and the quantities being held, it is necessary to periodically use a thermometer to check each item to ensure that the correct temperatures are being maintained. Check local health regulations for minimum serving temperatures.

#### Average Heated Surface Temperature

Setting	Temperature
Low	127°F (53°C)
Medium	160°F (71°C)
High	180°F (82°C)

## Cleaning and Preventative Maintenance

### Equipment Care

The cleanliness and appearance of this equipment will contribute considerably to operating efficiency and savory, appetizing food. Equipment that is kept clean works better and lasts longer.

### Thoroughly clean the appliance after each use

1. Remove the food from the carving station.
2. Set the heated surface rocker switch and the lamp switch to the Off (O) position. Disconnect the appliance from the power source. Allow the appliance to cool.
3. Remove and wash the cutting board after each use. Sanitize the cutting board following applicable state or local health sanitation ordinances. Allow the cutting board to air dry while lying on a clean, flat surface to prevent warping. If the board becomes warped, heating will restore flexibility to facilitate flattening.
4. Clean the exterior of the appliance with a mild soap and water solution. Apply the solution with a clean, damp cloth. Do not use commercial or household cleaners that contain ammonia. Wipe with a clean, damp cloth to remove all detergent residue. Dry with a clean, lint-free cloth.

**NOTICE:** Avoid the use of abrasive cleaning, compounds, chloride based cleaners, or cleaners containing quaternary salts. Never use hydrochloric acid (muriatic acid) on stainless steel.

5. Wipe surfaces with a sanitizing solution after cleaning and rinsing. This solution must be approved for use on stainless steel food contact surfaces.
6. Clean the appliance glass with glass cleaner or distilled vinegar.

Always follow appropriate state or local health (hygiene) regulations regarding all applicable cleaning and sanitation requirements for foodservice equipment.

### WARNING



To prevent serious personal injury, death, or property damage:

**Do not** steam clean, hose down or flood the interior or exterior with water or liquid solution of any kind. **Do not** use water jet to clean. Failure to observe this precaution will void the warranty.

For the most current wire diagrams, use the QR code or click link.

<b>77168</b> CS-100, CS-200 120V 60Hz		
<b>77207</b> CS-100, CS-200 230V 50/60Hz		

# Warranty

---

<b>Introduction</b>	Alto-Shaam, Inc. warrants to the original purchaser only, that any original part found to be defective in material or workmanship will be replaced with a new or rebuilt part at Alto-Shaam's option, subject to provisions hereinafter stated.
<b>Warranty Period</b>	<p>The original parts warranty period is as follows:</p> <ul style="list-style-type: none"> <li>• For all other original parts, one (1) year from the date of installation of appliance or fifteen (15) months from the shipping date, whichever occurs first.</li> <li>• The labor warranty period is one (1) year from the date of installation or fifteen (15) months from the shipping date, whichever occurs first.</li> <li>• Alto-Shaam will bear normal labor charges performed during standard business hours, excluding overtime, holiday rates or any additional fees.</li> <li>• For the refrigeration compressor, if installed, the warranty period is five (5) years from the date of original installation of the appliance.</li> <li>• For heating elements on Halo Heat® Cook and Hold ovens, the warranty period is for as long as the original owner owns the oven. This warranty period applies to units sold after 2/1/2009 and excludes holding-only ovens.</li> <li>• To be valid, a warranty claim must be asserted during the applicable warranty period. This warranty is not transferable.</li> </ul>
<b>Exclusions</b>	<p>This warranty does not apply to:</p> <ul style="list-style-type: none"> <li>• Calibration.</li> <li>• Replacement of light bulbs, rubber gaskets, grease filters, air filters, racks, jet plates, and/ or the replacement of glass due to damage of any kind.</li> <li>• Equipment damage caused by accident, shipping, improper installation or alteration.</li> <li>• Equipment used under conditions of abuse, misuse, carelessness or abnormal conditions, including but not limited to, equipment subjected to harsh or inappropriate chemicals, including but not limited to, compounds containing chloride or quaternary salts, poor water quality, or equipment with missing or altered serial numbers.</li> <li>• Equipment damage caused by use of any cleaning agents other than those recommended by Alto-Shaam, including but not limited to damage due to chlorine or other harmful chemicals.</li> <li>• Any losses or damage resulting from malfunction, including loss of food product, revenue, or consequential or incidental damages of any kind.</li> <li>• Equipment modified in any manner from original model, substitution of parts other than factory authorized parts, unauthorized removal of any parts including legs, or unauthorized addition of any parts.</li> <li>• Equipment damage incurred as a direct result of poor water quality*, inadequate maintenance of steam generators and/or surfaces affected by water. Water quality and required maintenance of steam generating equipment is the responsibility of the owner/ operator.</li> <li>• Equipment damage incurred as a result of not following the required maintenance schedule published in the manuals for the equipment.</li> </ul>
<b>Conclusion</b>	<p>This warranty is exclusive and is in lieu of all other warranties, express or implied, including the implied warranties of merchantability and fitness for a particular purpose. No person except an officer of Alto-Shaam, Inc. is authorized to modify this warranty or to incur on behalf of Alto-Shaam any other obligation or liability in connection with Alto-Shaam equipment.</p> <p><i>*Refer to the product spec sheet for water quality standards.</i></p>









# ALTO-SHAAM.

Menomonee Falls, WI U.S.A.

Phone 800-558-8744 | +1-262-251-3800 | [alto-shaam.com](http://alto-shaam.com)

## ASIA

Shanghai, China  
Phone +86-21-6173-0336

## AUSTRALIA

Brisbane, Queensland  
Phone 800-558-8744

## CANADA

Concord, Ontario Canada  
Toll Free Phone 866-577-4484  
Phone +1-905-660-6781

## FRANCE

Aix en Provence, France  
Phone +33(0)4-88-78-21-73

## GMBH

Bochum, Germany  
Phone +49 [0]234 298798-0

## ITALY

Padua, Italy  
Phone +39 3319273313

## INDIA

Pune, India  
Phone +91 9657516999

## MEXICO

Phone 262-251-3800 Ext. 6506

## MIDDLE EAST & AFRICA

Dubai, UAE  
Phone +971-4-321-9712

## CENTRAL & SOUTH AMERICA

Miami, FL USA  
Phone 262-251-3800 Ext. 6506