



BEVERAGE-AIR®

PROJECT: _____
 ITEM # _____ QTY: _____
 MODEL # _____
 AIA # _____ SIS # _____
 APPROVED: _____

VISTA® BOTTOM MOUNT REACH-IN REFRIGERATOR

Model: RB49HC-1G

GLASS DOORS

VISTA® BOTTOM MOUNT REACH-IN REFRIGERATOR



7 YEAR WARRANTY Parts, Labor, and Compressor

CABINET CONSTRUCTION

- Stainless steel front and grille, gray painted sides
- Gray painted aluminum interior
- Full electronic control
- LED lighting
- Self-closing door with 120° stay-open feature, on spring-loaded hinges
- One-piece grille allow easy removal/installation for preventative maintenance
- Six (6) heavy duty epoxy coated wire shelves standard
- 6" Casters standard with (2) brakes



OPTIONS & ACCESSORIES

- Epoxy shelves (5 max per section)
- Shelf clips
- 3" Casters or 6" legs
- 6" Flanged/seismic feet
- Door lock
- Remote option* (see note on back page)

REFRIGERATION SYSTEM

- Epoxy shelves (5 max per section)
- Shelf clips
- 3" Casters or 6" legs
- 6" Flanged/seismic feet
- Door lock
- Remote option* (see note on back page)



BEVERAGE-AIR®

Vista® Bottom Mount Refrigerator

Model: RB49HC-1G

PLAN VIEW

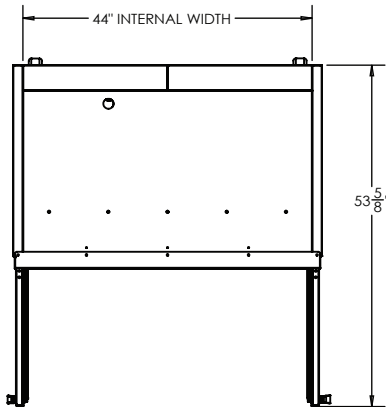

ELEVATION VIEW

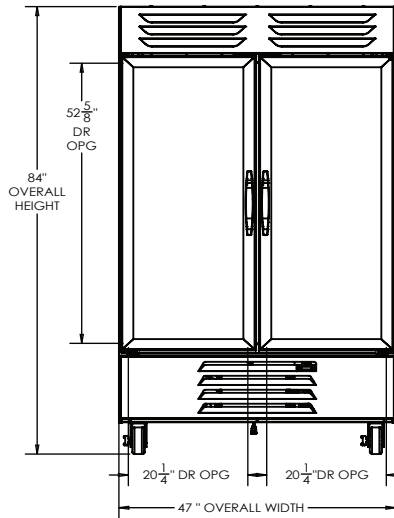

SIDE VIEW

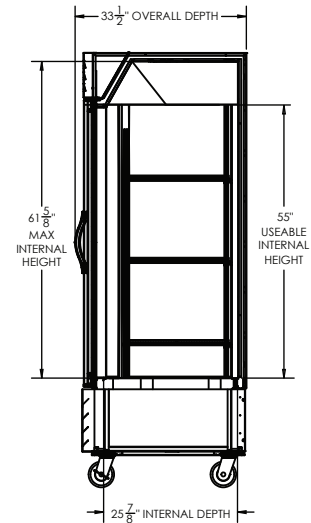

EXTERNAL DIMENSIONAL DATA	
Width Overall (in)	52"
Depth Overall (in)	33 1/2"
Height Overall (in)	84 1/4"
Number of Doors	2
Depth with Door open 90° (in)	56"
Door Openings (in)	22 5/8" x 52 5/8"
INTERNAL DIMENSIONAL DATA	
NET Capacity (cubic ft.)	46.15
Internal Width Useable (in)	49"
Internal Depth Overall (in)	26"
Internal Height Overall (in)	61 5/8"
Number of Shelves	6

ELECTRICAL DATA	
Full Load Amps	3.9
Voltage	115/60/1
Nema Plug (8' cord)	5-15P
REFRIGERATION DATA	
Horsepower	1/3
Capacity (BTU/Hr)	2291
Heat Rejection (BTU/Hr)	3436.5
Charge (lbs/grams/ounces)	0.2425 / 110 / 3.88
SHIPPING DATA	
Gross Weight - Crated	566 lbs.
Height - Crated (in)	85"
Width - Crated (in)	54"
Depth - Crated (in)	36"

*NOTE: Remote units are field wired and come with 6" legs. Refrigerant must be specified at time of order.

We reserve the right to change specifications and product design without notice. Such revisions do not entitle the buyer to corresponding changes, improvements, additions or replacements for previously purchased equipment. Dimensional tolerances +/- 1/4". Metric dimensions (MM).

ELECTRICAL CONNECTION



115/60/1
5-15P

Unit pre-wired at factory and include 8' long cord and plug set.

3779 Champion Blvd., Winston-Salem, NC 27105 | 888-845-9800 | Fax: 336-245-6453 | Beverage-Air.com | Sales@bevair.com

Date Issued 9/25 | Printed in U.S.A.