

Converge[®]

Deluxe Control

CMC-H2H

CMC-H3H



Structured Air Technology™

MN-47239-EN

REV.09
02/26

EN

For the most current manual, visit alto-shaam.com
Die neueste Fassung des Handbuchs finden Sie auf alto-shaam.com
Pour la dernière version du manuel, visiter alto-shaam.com
Para obtener el manual más actual, visite alto-shaam.com
Ga voor de meest recente handleiding naar alto-shaam.com



Manufacturer's Information

Copyright

© Copyright 2/26 by Alto-Shaam, Inc.

All rights reserved.

This manual or any portion thereof may not be reproduced or used in any manner whatsoever without the express written permission of Alto-Shaam, Inc.

Trademarks

All trademarks referenced in this documentation are the property of their respective owners.

Manufacturer

Alto-Shaam, Inc.

P.O. Box 450

W164 N9221 Water Street

Menomonee Falls, WI 53052

Original instructions

The content in this manual is written in American English.

Software and manual updates

The information in this manual was current at the time of production. See www.alto-shaam.com for the latest software and manual.

Enjoy your Alto-Shaam Converge Oven!

Structured Air Technology™

The Alto-Shaam Converge Oven features Structured Air Technology, giving you two or three ovens in one. It combines the flexibility of a multi-cook oven and the versatility of combi cooking in each oven chamber. Two or three independent ovens in one give you the freedom to steam, air fry, bake, grill, and more at the same time without flavor transfer—all in a ventless, self-cleaning design. It provides the ability to control temperature, fan speed, humidity level, and cook time in each individual oven chamber.

Extend Your Manufacturer's Warranty

Register

Register your Alto-Shaam appliance online. Registering your appliance ensures prompt service in the event of a warranty claim.

Your personal information will not be shared with any other company.

alto-shaam.com/warranty

Alto-Shaam 24/7 Emergency Repair Service

Call

Call 800-558-8744 to reach our 24-hour emergency service call center for immediate access to local authorized service agencies outside standard business hours. The emergency service access is provided exclusively for Alto-Shaam equipment and is available throughout the United States through Alto-Shaam's toll free number.

Availability

Emergency service access is available seven days a week, including holidays.

This page is intentionally left blank.

Manufacturer’s Information 2

Foreword 3

 Enjoy your Alto-Shaam Converge Oven! 3

 Extend Your Manufacturer’s Warranty 3

 Alto-Shaam 24/7 Emergency Repair Service 3

Table of Contents 5

Safety 7

 The Meaning of Signal Words 7

 Appliance Description and Intended Use. 8

 Safety Precautions. 9

Labels 13

 Label Locations 13

Installation 21

 Dimension Drawings 21

 How to Unpack the Oven 23

 ChefLinc Installation Checklist 24

 How to Install the Water Supply and Drain. 26

 How to Install the Oven (60 Hz Cord and Plug Models). 32

 How to Install the Oven (50 Hz Models Without Cord or Plug). 35

 How to Install the Oven on a Stand 40

 How to Install Ovens that have Hoods 46

 How to Install the Jet Plates 47

 How to View and Set up WiFi Connection. 50

 How to Set up an Ethernet Connection 53

Operation 57

 How to Turn On and Turn Off the Oven 57

 How to Preheat the Oven. 58

 How to Preheat the Oven with Multiple Preheat Setpoints. 61

 How to Cook with Programmed Recipes 65

 How to Cook in Manual Mode 67

 How to Cook in Professional Mode 71

 How to Use the Dual Timers 74

 How to Lock and Unlock the Screen. 78

 How to Cool Down the Oven. 79

 How to Create a Recipe. 80

 How to Modify, Duplicate, or Delete a Recipe 85

 How to Create a Category 87

 How to Backup or Restore Settings with a USB Drive. 90

 How to Backup Recipes to a USB Drive 92

How to Restore Recipes from a USB Drive	94
How to Import Images from a USB Drive	96
How to Update Software with a USB Drive	98
How to Check for and Download Available Software Updates	101
How to Temporarily Change Languages	103
How to Temporarily Change Temperature Units	104
How to Change the Home Screen	105
How to Change the Temperature Scale	107
How to Change the Cooking Complete Notification Sound	109
How to Enable/Disable Automatic Preheat	111
How to Enable/Disable “Press and Hold” Cook Cancel function.	112
How to Enable and Use the Replay Function	113
How to Lock Recipe Editing, Manual Cooking, or the Settings Screen	115
How to View Oven Information	117
How to Download HACCP Data	118
How to Calibrate the Temperature Probe	120
Maintenance	123
Maintenance Schedule	123
How to Clean the Oven.	125
How to Descale the Catalyst.	129
How to View the Cleaning Log	132
How to Set the Cleaning Frequency	133
How to Set Up Visible Cleanings	135
How to Set Up Cleaning Lockout	137
How to Winterize the Oven	139
Troubleshooting	141
Error Codes	141
What to do if the Fan Indicator Light Illuminates	144
What to do if the High Limit Screen Displays	145
Cheflincv2.alto-shaam.com/# is Not Available on Your Device	146
Cannot Connect to cheflincv2.alto-shaam.com/#.	147
The Oven is not Displayed on the Dashboard	148
Unable to Assign Recipes from the Dashboard to Ovens in the Field	149
Notifications	151
Notifications.	151
Conditions for Ovens Installed in New York City	154
Warranty	155
Warranty.	155
Declaration of Conformity	157

The Meaning of Signal Words

This manual contains signal words where needed. These signal words must be obeyed to reduce the risk of death, personal injury, or equipment damage. The meaning of these signal words is explained below.

**DANGER**

Danger indicates a hazardous situation which, if not avoided, will result in serious injury or death.

**WARNING**

Warning indicates a hazardous situation which, if not avoided, could result in serious injury or death.

**CAUTION**

Caution indicates a hazardous situation which, if not avoided, could result in minor or moderate injury.

NOTICE

Notice indicates a situation which, if not avoided, could result in property damage.



NOTE: Note indicates additional information that is important to a concept or procedure.

Appliance Description and Intended Use

Structured Air Technology®

Alto-Shaam Structured Air Technology system allows for multiple, unique cooking chambers within the same oven. Air is delivered by a blower located in the rear of each cooking chamber. Air travels vertically through the jet plates into each chamber. The food product is blown with hot air from above and below. Structured Air plates at the top and bottom of the oven complete the upper and lower cooking chambers. Each cooking chamber is independent from the other and includes its own blower and heat source. The operator can select the optimal cooking temperature, air velocity, humidity level, and cook time for each chamber either manually or through programmed recipes.

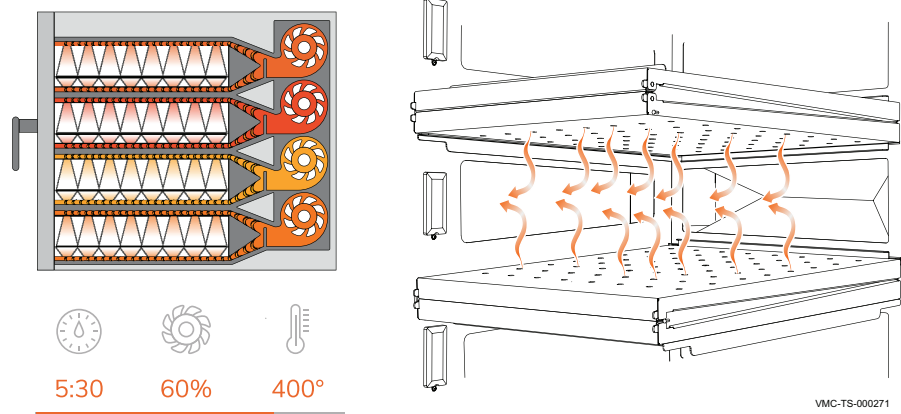

Nomenclature

CMC-H2H means Combi Multi-Cook, half-size, two-chamber, and hotel pans.
CMC-H3H means Combi Multi-Cook, half-size, three-chamber, and hotel pans.

Configurations

Converge is available in two configurations: two- and three-chamber.

Intended use

Converge ovens are intended to cook and steam food only. Any other use is prohibited. This appliance is intended to be used for commercial applications, for example in kitchens of restaurants, canteens, hospitals and in commercial enterprises such as bakeries, butcheries, etc., but not for continuous mass production of food.

Residual risks

This oven is manufactured using ISO-certified processes. The oven is designed with maximum safety in mind; however, there are residual risks to operators of this oven. Residual risks include exposure to heat and exposure to hot food products.

Possible misuse

Misuse of this oven includes loading the oven with anything other than a food product. Misuse also includes heating or cooking any food product that contains alcohol or other flammable substance.

Safety Precautions

Before you begin

Read and understand all instructions in this manual.

Electrical precautions

Obey these electrical precautions when using the appliance:

- Connect the appliance to a properly grounded outlet. Do not use the appliance if it is not properly grounded. Consult an electrician if there is any doubt that the outlet used is properly grounded.
 - Keep the cord away from hot surfaces.
 - Do not attempt to service the appliance or its cord and plug.
 - Do not operate the appliance if it has a damaged cord or plug.
 - Do not immerse the cord or plug in water.
 - Do not let the cord hang over the edge of a table or counter.
 - Do not use an extension cord.
-

Usage precautions

Obey these usage precautions when using the appliance:

- Only use this appliance for its intended use of heating or cooking.
 - Always keep liquids, or foods that can become liquid when heated, level and at or below eye level where they can be seen.
 - Use utensils and protective clothing such as dry oven mitts when loading and unloading the appliance.
 - Use caution when using the appliance. Floors adjacent to the appliance may become slippery.
 - Do not cover or block any of the openings of this appliance.
 - Do not cover racks or any other part of this appliance with metal foil.
 - Do not keep anything underneath the oven. Cooling air circulates through the bottom for the electronics.
 - Do not use this appliance near water such as a sink, in a wet location, near a swimming pool, or similar locations.
 - Do not unplug or disconnect the appliance immediately after cooking. The cooling fans must stay on to protect electrical components.
-

Maintenance precautions

Obey these maintenance precautions when maintaining the appliance:

- Obey precautions in the manual, on tags, and on labels attached to or shipped with the appliance.
- Do not store the appliance outdoors.
- Do not clean the appliance with metal scouring pads.
- Do not use corrosive chemicals when cleaning the appliance.
- Do not use a hose, water jet, or steam cleaner to clean the exterior of the appliance.
- Do not use the appliance cavity for storage.
- Do not leave flammable materials, cooking utensils, or food inside the appliance when it is not in use.
- Do not remove the top cover or side panels. There are no user-serviceable components inside.

Operator training

All personnel using the appliance must have proper operator training. Before using the appliance:

- Read and understand the operating instructions contained in all the documentation delivered with the appliance.
- Know the location and proper use of all controls.
- Keep this manual and all supplied instructions, diagrams, schematics, parts lists, notices, and labels with the appliance if the appliance is sold or moved to another location.
- Contact Alto-Shaam for additional training if needed.

Operator qualifications

Only trained personnel with the following operator qualifications are permitted to use the appliance:

- Have received proper instruction on how to use the appliance.
- Have demonstrated their ability with commercial kitchens and commercial appliances.

The appliance must not be used by:

- Persons (including children) with reduced physical, sensory or mental capabilities, or lack of experience and knowledge, unless they have been given supervision concerning use of the appliance by person responsible for their safety.
- People impaired by drugs or alcohol.

- Children should be supervised to ensure that they do not play with the appliance.
- Children shall neither clean nor maintain the appliance.

Condition of appliance

Only use the appliance when:

- All controls operate correctly.
- The appliance is installed correctly.
- The appliance is clean.
- The appliance labels are legible.

Servicing the appliance

- Only trained personnel are permitted to service or repair the appliance. Repairs that are not performed by an authorized service partner or trained technician will void the warranty and relieve Alto-Shaam of all liability. Original manufacturer's replacement parts may be substituted; however, these parts must be of equal quality and specifications as those provided by Alto-Shaam.
- To prevent serious injury, death or property damage, have the appliance inspected and serviced at least every twelve (12) months by an authorized service partner or trained technician.
- Contact Alto-Shaam for the authorized service partner in your area.

Sound power

The A-weighted sound pressure level is below 70 dB(A).

Personal Protective Equipment (PPE)

Wear the following Personal Protective Equipment (PPE) while cleaning the appliance:

- Protective gloves
 - Protective clothing
 - Eye protection
 - Face protection
-

Use of restraining devices

A restraining device (tether) must be installed to any appliance that is hard-wired and mounted on casters. The tether must:

- Be secured to the building's structure.
- Limit the movement of the appliance so that no stress is transmitted to the electrical conduit.

A connection point for the tether is located on the back of the appliance.

A tether is not supplied by nor available from the manufacturer.

This page is intentionally left blank.



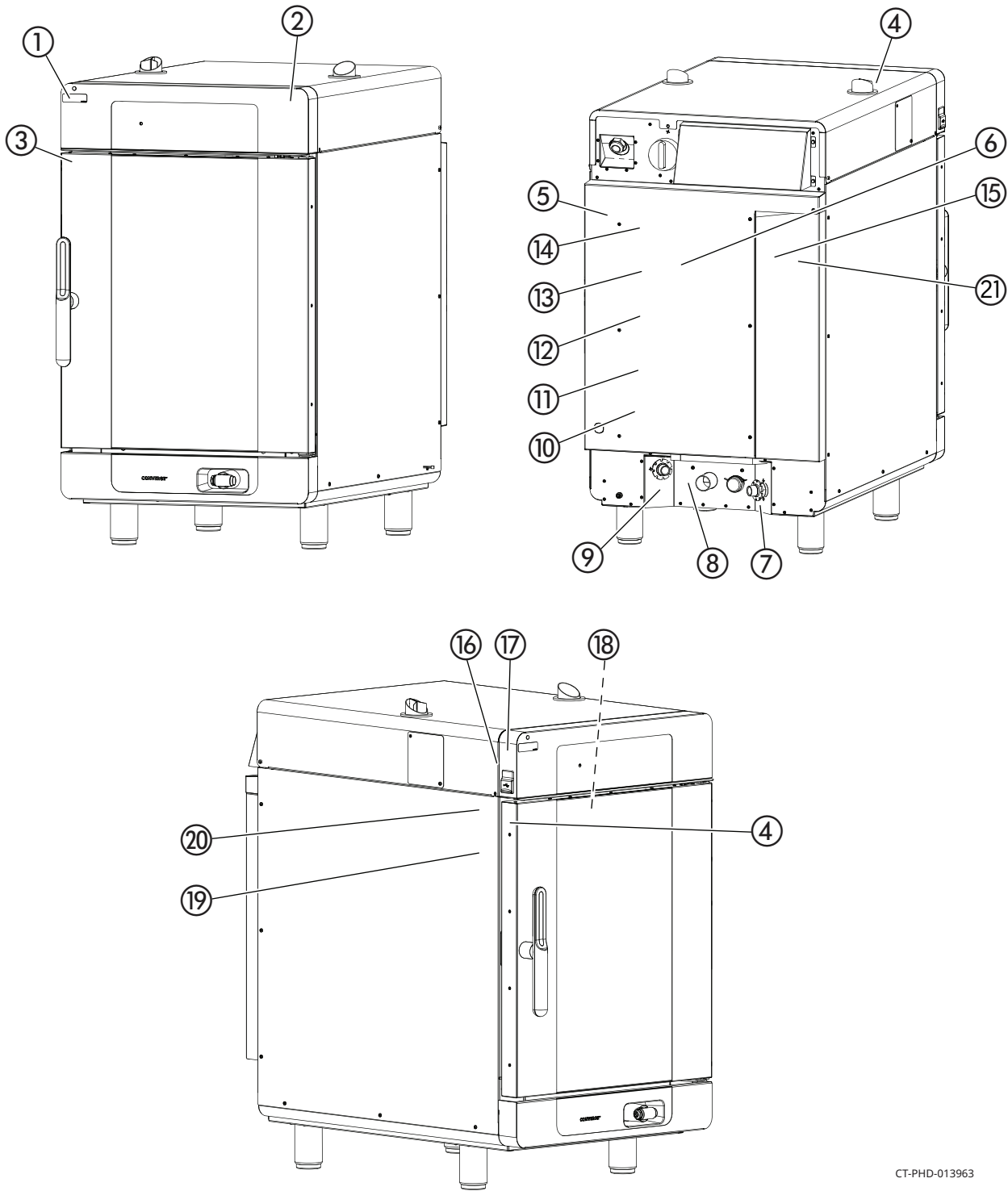

Label Locations



CT-PHD-013963

LABELS

LABELS

<p>1</p>	<div data-bbox="259 216 639 338" style="border: 1px solid black; border-radius: 10px; padding: 5px;"> <p>Check fans Compruebe los ventiladores Vérifiez les ventilateurs</p> <p style="text-align: right; font-size: small;">LA-39033</p> </div> <div data-bbox="259 371 639 493" style="border: 1px solid black; border-radius: 10px; padding: 5px; margin-top: 10px;">  <p style="text-align: right; font-size: small;">LA-39280</p> </div>	<p>Check fans</p>
<p>2</p>		<p>Made in U.S.A.</p>
<p>3</p>		<p>WARNING Steam. Open door carefully.</p>
<p>4</p>		<p>WARNING Hot surface</p>
<p>5</p>	<div data-bbox="259 1098 639 1318" style="border: 1px solid black; border-radius: 10px; padding: 10px;"> <p style="text-align: center;">ALTO-SHAAM.</p> <p>Every Alto-Shaam product is precision calibrated prior to release from the factory to ensure accurate temperature control.</p> <p style="text-align: center;">CALIBRATION TECHNICIAN _____</p> <p style="font-size: x-small;">LA-26378</p> </div>	<p>Every Alto-Shaam product is precision calibrated prior to release from the factory to ensure accurate temperature control.</p>

6

**WARNING
ADVERTENCIA
AVERTISSEMENT**

Failure to follow cleaning instructions can cause injury or equipment damage. Clean oven only with Alto-Shaam cleaning tablets. Avoid contact with skin or eyes. Wear PPE. Read and understand the safety data sheet and the operator's manual before cleaning.

Si no se siguen las instrucciones de limpieza, puede sufrir lesiones o daños en el equipo. Limpie el horno solo con las pastillas de limpieza de Alto-Shaam. Evite el contacto con la piel o los ojos. Use equipo de protección personal (Personal Protective Equipment, PPE). Lea completamente la hoja de datos de seguridad y el manual del operador antes de realizar la limpieza.

Pour écarter les risques de blessures ou de dégâts matériels, veillez à respecter les instructions de nettoyage. Nettoyer le four uniquement avec les pastilles nettoyantes Alto-Shaam. Éviter le contact avec la peau et les yeux. Porter un EPI. Lire et comprendre la fiche de données de sécurité et le manuel de l'utilisateur avant de nettoyer.

LA-48004

LA-39149

WARNING

Failure to follow cleaning instructions can cause injury or equipment damage. Clean oven only with Alto-Shaam concentrated cleaning tablets. Cleaner is caustic. Avoid contact with skin or eyes. Wear PPE. Read and understand the safety data sheet and the operator's manual before cleaning.

7

LA-38909

Treated, drinkable water connection point.

8

LA-38911

Drain water connection point.

9

LA-38910

Untreated, drinkable water connection point.

10

⚠ WARNING/ADVERTENCIA/AVERTISSEMENT

Electric Shock Hazard
Appliances with permanent electrical connection that are mounted on casters must be secured to building structure. Read installation instructions.

Peligro de descarga eléctrica
Los equipos con una conexión eléctrica permanente que estén montados sobre ruedas deben estar fijos a la estructura del edificio. Lea las instrucciones de instalación.

Risque d'électrocution
Les appareils à branchement électrique fixe qui sont montés sur roulettes doivent être attachés à la structure du bâtiment. Lire les instructions d'installation.

LA-38912

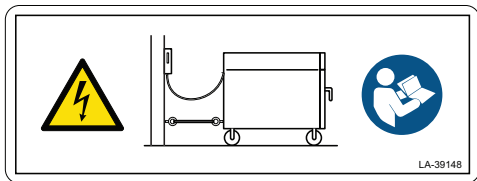

WARNING

Electric shock hazard

Appliances with permanent electrical connections that are mounted on casters must be secured to building structure. Read installation instructions.

11

⚠ WARNING/ADVERTENCIA/AVERTISSEMENT

Fire Hazard
This appliance is only for use with factory-supplied legs, casters, or base.

Peligro de incendio
Este aparato solo se puede usar con patas, ruedas o base proporcionadas por la fábrica.

Risque d'incendie
Ce appareil est destiné à être utilisé uniquement avec les pieds, les roulettes ou le socle fournis par le fabricant.

LA-39335

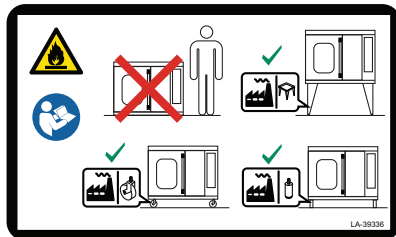

WARNING

Fire hazard

This oven is only for use with factory-supplied legs, casters, or base.

12

⚠ WARNING/ADVERTENCIA/AVERTISSEMENT

Fire Hazard
For use only on noncombustible surfaces. Maintain the correct clearances to combustibles.

Peligro de incendio
Solo para uso en superficies no combustibles. Mantenga las distancias correctas de elementos combustibles.

Risque d'incendie
Utilisation sur des surfaces non combustibles seulement. Maintenir des dégagements corrects par rapport aux matières combustibles.

	Combustibles	Non-combustibles
Top/lope/haut	2" (51mm)	2" (51mm)
Left/izquierda/gauche	2" (51mm)	2" (51mm)
Right/derecho/droite	2" (51mm)	2" (51mm)
Rear/posterior/arrière	2" (51mm)	2" (51mm)



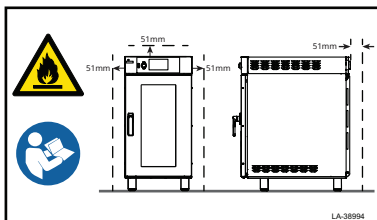

LA-39090

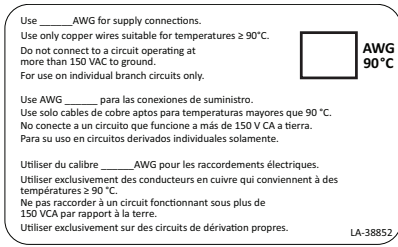
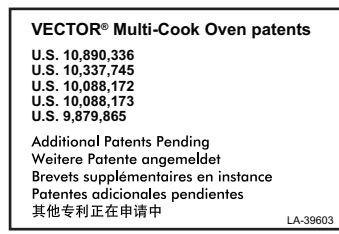

WARNING

Fire hazard

For use only on noncombustible surfaces. Maintain the correct clearances to combustibles.

<p>13</p>	 	<p>WARNING</p> <p>Electric shock hazard</p> <p>To reduce the risk of electric shock, do not remove or open cover. No user-serviceable parts inside. Refer servicing to qualified personnel.</p> <p>Qualified personnel: Disconnect power before servicing.</p>
<p>14</p>		<p>Note: This label is only used on UL-certified appliances that have 120V to ground wiring.</p> <p>Use _____ AWG for supply connections.</p> <p>Use only copper wires suitable for temperature less than or equal to 90°C.</p> <p>Do not connect to a circuit operating at more than 150 VAC to ground.</p> <p>For use on individual branch circuits only.</p>
<p>15</p>		<p>Vector Multi-Cook Oven Patents</p>
<p>16</p>		<p>Certificate of Approval number, Fire Department - City of New York.</p>
<p>17</p>		<p>Security seal</p>

18

⚠ WARNING / ADVERTENCIA / AVERTISSEMENT

Burn hazard. Always load liquids, or foods that can become liquid when heated, at an eye level where they can be seen.

Peligro de quemaduras. Siempre coloque líquidos, o alimentos que se puedan volver líquidos cuando se calientan, a nivel de los ojos donde se puedan ver.

Risque de brûlure. Toujours charger les liquides, ou les aliments qui deviennent liquides au chauffage, à hauteur des yeux où ils peuvent être vus.

LA-39123



WARNING

Burn hazard

Always load liquids, or foods that can become liquid when heated, at an eye level where they can be seen.

19

	Σ kg max.	Σ liter max.	Σ GN 1/1
CMC-2	16	10.88	2
CMC-3	24	16.32	3

LA-47321

Retherm maximum capacity

20

For use on individual branch circuit only.

Utiliser exclusivement sur un propre circuit de dérivation séparé.

Nur zum Anschluss an einen Einzelstromkreis geeignet.

Para su uso en circuitos derivados individuales solamente.

禁止和其他任何电器设备共用供电回路。必须独立分配一路给该设备

LA-3088

For use on individual branch circuit only.

21



Alto-Shaam technical service QR code

<p>—</p>		<p>Press and release the high limit temperature reset button(s).</p>
<p>—</p>		<p>Equipotential terminal</p>
<p>—</p>		<p>Consult instructions for operation and use.</p>

This page is intentionally left blank.

Dimension Drawings

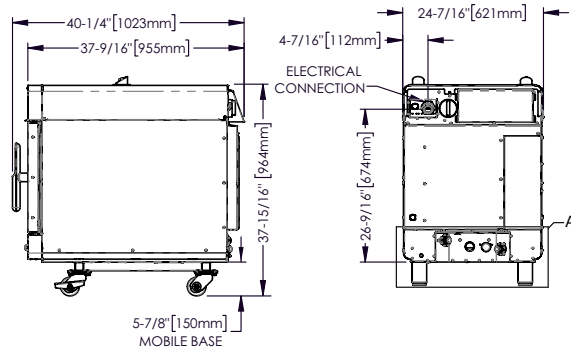
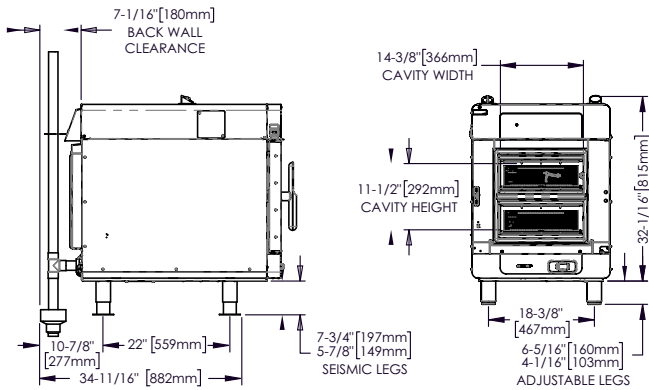
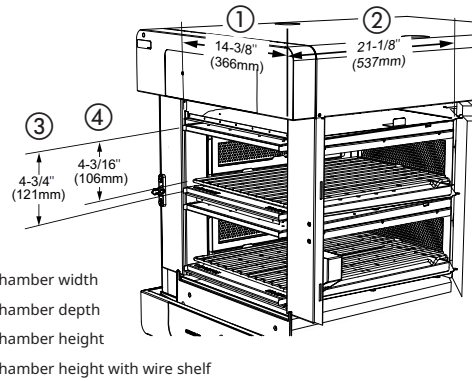
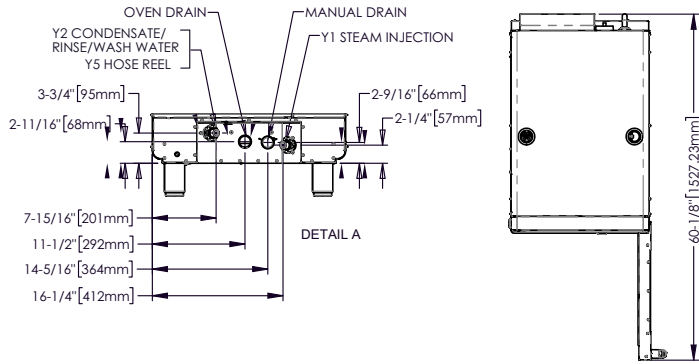

Continued on next page

INSTALLATION

Continued from previous page

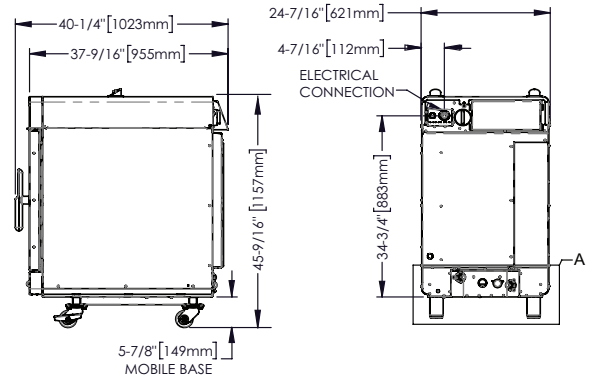
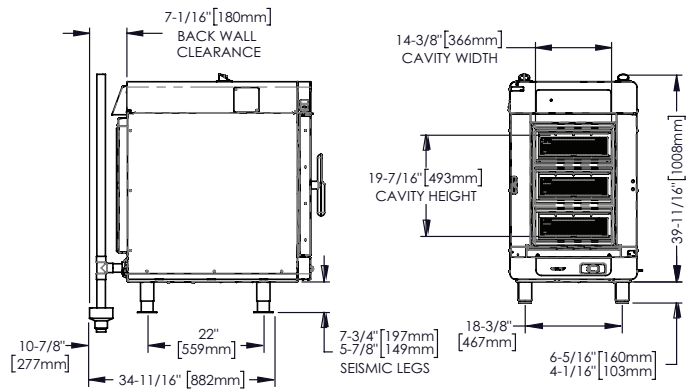
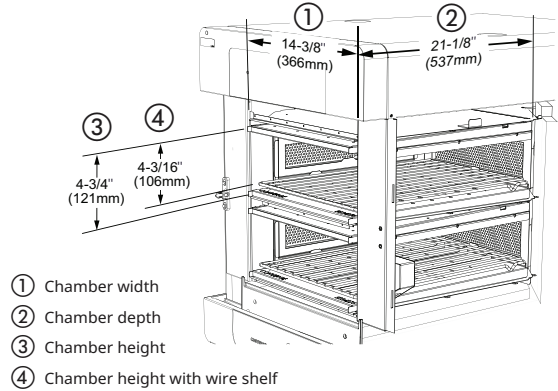
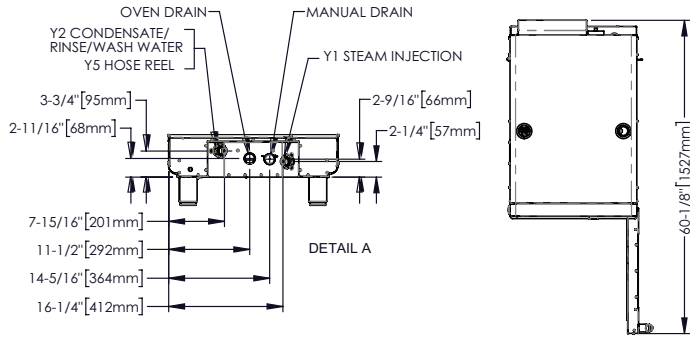

How to Unpack the Oven

Before you begin

Make sure you have:

- An appropriate lifting device and enough personnel to safely move and position the weight of the oven.
 - CMC-H2H: 304 lb (138 kg)
 - CMC-H3H: 394 lb (179 kg)
- Cutting tools to remove the packaging.

Unpack the oven

To unpack the oven, do the following.

Step	Action
1.	Remove the box. Save all packing materials for inspection by the carrier.
	<div style="border: 1px solid black; padding: 5px;"> <p> NOTE: Examine the appliance for damage. If the appliance has been damaged, do not use the appliance until it has been inspected by an authorized service provider. Contact your carrier or Alto-Shaam customer service.</p> </div>
2.	Remove the shrink wrap.
3.	Cut the restraining straps.
4.	Remove the probe from the foam block.
5.	Remove the foam from each chamber.
6.	Remove the oven from the pallet.
7.	Remove the protective paper from the outside of the oven.

Result

The oven is now unpacked.

ChefLinc Installation Checklist

Place this form with the oven's records.

Connectivity Pre-Installation Checklist

Will you connect the oven to the Internet using Wi-Fi or Ethernet?	Wi-Fi	Ethernet	Unable to answer
--	-------	----------	------------------

Wi-Fi Connections

Is the Wi-Fi network that is to be used a WPA2 secured network?	Yes	No	Unable to answer
Is this network also used to send and receive point of sale information (credit card data, register receipts)? This is NOT recommended for any installation.	Yes	No	Unable to answer
Have you been provided with the network name (SSID) for the oven to connect to?	Yes	No	Unable to answer
Have you been provided the password for the Wi-Fi network to be used?	Yes	No	Unable to answer
At the final location that the oven will be installed, can you connect to the Wi-Fi system with your phone?	Yes	No	Unable to answer
Using your phones Wi-Fi connection, are you able to connect to alto-shaam.com? You are testing for any additional security on the network to block access to external sites. You will need to turn off your cellular service on your phone to make sure you're using the Wi-Fi network.	Yes	No	Unable to answer

Ethernet Connections

At the final location that the oven will be installed, is there an open Ethernet port conveniently located?	Yes	No	Unable to answer
Is the Ethernet port live (providing Internet access)?	Yes	No	Unable to answer
Is the Ethernet harness accessory ordered with the unit?	Yes	No	Unable to answer

Is there site action required?	Yes	No
--------------------------------	-----	----

Action required:

Continued on next page

Continued from previous page

Connectivity Installation Checklist

Refer to Network Status screen

What is your connection type?	Wi-Fi	Ethernet
What color is the network status icon?	Red Yellow	Green
What is the Internet status?	Connected	Not connected
What is the cloud status?	Connected	Not connected
What is the update server status?	Connected	Not connected
What is the SSID (network name)?		
What is the password?		
What is the IP address?		
What is the Front End (FE) software version number?		
What is the Back End (BE) software version number?		
What is the Control Board (CB) software version number?		
Is this the latest software version?	Yes	No
Validate via: https://www.alto-shaam.com/en/customer-support/software-downloads		

How to Install the Water Supply and Drain

Before you begin



NOTE: Refer to the detailed instructions that come with the installation kit.

NOTICE

Significant damage to the appliance cavity, elements, or heat exchanger could result from improper water quality. Failure to meet the water quality requirements will void the warranty.

NOTICE

Do not install a stacked set of ovens or a floor standing oven directly over a drain. Steam rising from the drain may adversely affect operation and damage electrical components.

Exception:

An oven on a stand that includes a solid bottom or solid shelf may be installed directly over a drain because the shelf or solid bottom will prevent steam from entering the oven.

Make sure:

- The supply lines are flexible to allow the oven to be moved when service or cleaning is needed.
- For units under IEC/EN jurisdiction: This appliance is intended to be permanently connected to the water mains. Comply with local codes when installing this appliance.
- The incoming water supply is shut off when the oven is not being used.

Requirements

Water requirements:

- Two (2) water inlets, drinking quality.
- One treated water inlet: 3/4" NPT male connection. Line pressure 30 psi (200 kPa) minimum dynamic and 145 psi (1000 kPa) maximum static at a minimum flow rate of 0.16 gpm (0.6 L/min).
- One untreated water inlet: 3/4" NPT male connection. Line pressure 30 psi (200 kPa) minimum dynamic and 145 psi (1000 kPa) maximum static at a minimum flow rate of 4.0 gpm (15 L/min).
- Water temperature range: 50°–140°F (10°–60°C)
- One (1) 3/4" ID water supply shut-off valve and back-flow preventer per oven where required by local code.
- Water drain: 1-1/2" No HUB connection with air gap at floor. Materials must withstand temperatures up to 200°F (93°C).
- Drain may not be directly below oven.

Continued on next page

Continued from previous page

It is the responsibility of the operator to make sure the incoming water supply is tested and meets the compliance requirements with the published water quality standards listed below. Non-compliance could damage the oven and void the warranty. Alto-Shaam recommends using OptiPure products to treat the water.

Contaminant	Treated Water	Untreated Water
Free Chlorine	less than 0.1 ppm (mg/L)	less than 0.1 ppm (mg/L)
Hardness	30–70 ppm	30–70 ppm
Chloride	less than 30 ppm (mg/L)	less than 30 ppm (mg/L)
pH	7.0–8.5	7.0–8.5
Silica	less than 12 ppm (mg/L)	less than 12 ppm (mg/L)
Total Dissolved Solids (TDS)	50–125 ppm	50–360 ppm

Requirements for Australia and New Zealand

For Australia, the installation must meet AS/NZ3500.1 and AS/NZ3500.2 specifications. All plumbing must be done by a licensed plumber.

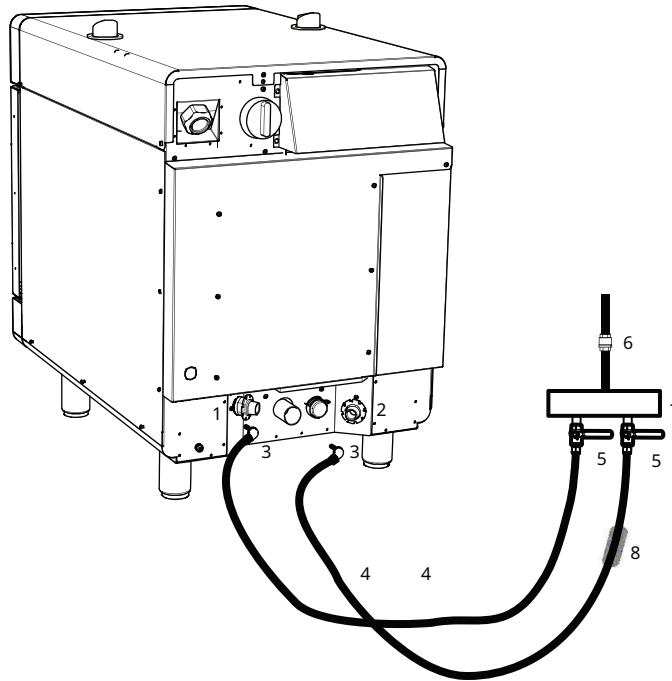

1. Untreated water inlet	5. Shut-off valve
2. Treated water inlet	6. Check Valve (inspect yearly)
3. Install a 90° fitting whenever possible on each water line	7. Manifold
4. Connect a flexible water line to each inlet fitting	8. Filter

Continued on next page

Installing the water supply

Continued from previous page

To install the water supply, do the following.

Step	Action
1.	Flush the water line at the installation site.
2.	Install adequate backflow protection to comply with applicable federal, state, and local codes.
3.	Remove the two adapter fittings on the water inlets.
	
4.	Apply thread sealant to the threads of the adapter fittings. Install the elbow from the kit onto the adapter fitting.
	
5.	Install the adapter fittings and elbows onto the water inlets with slip joint pliers. Tighten the fittings until the elbows have a slight downward angle.
	

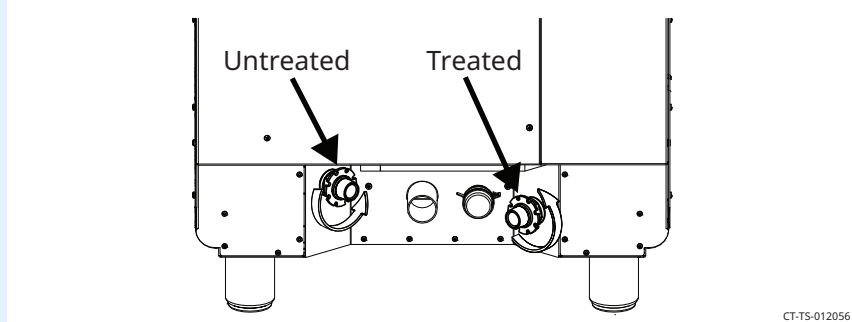

CT-TS-012056

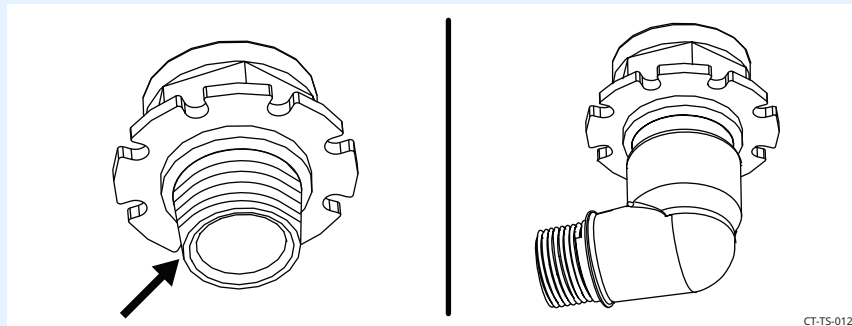

CT-TS-012

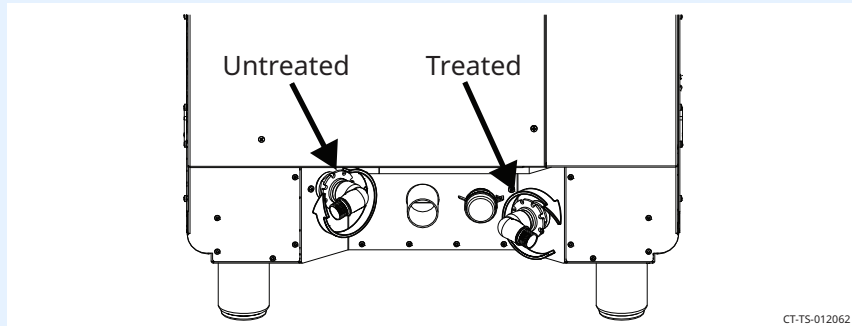

CT-TS-012062

Continued on next page

Continued from previous page

6. **Install** the water hoses onto the elbows.

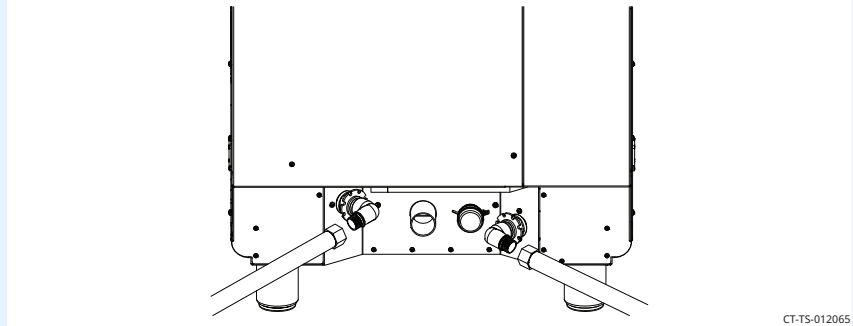

CT-TS-012065

Installing the water drain

Install a 1-1/2" (40mm) diameter connection, drain line and clamp into place. The drain line must always slope downward away from the oven. An end-of-drain air gap may be required by local code. Vertical air vent required.

NOTICE

In the U.S.A., this equipment must be installed to comply with the Basic Plumbing Code of the Building Officials and Code Administrators International, Inc. (BOCA), and the Food Service Sanitation Manual of the Food & Drug Administration (FDA).

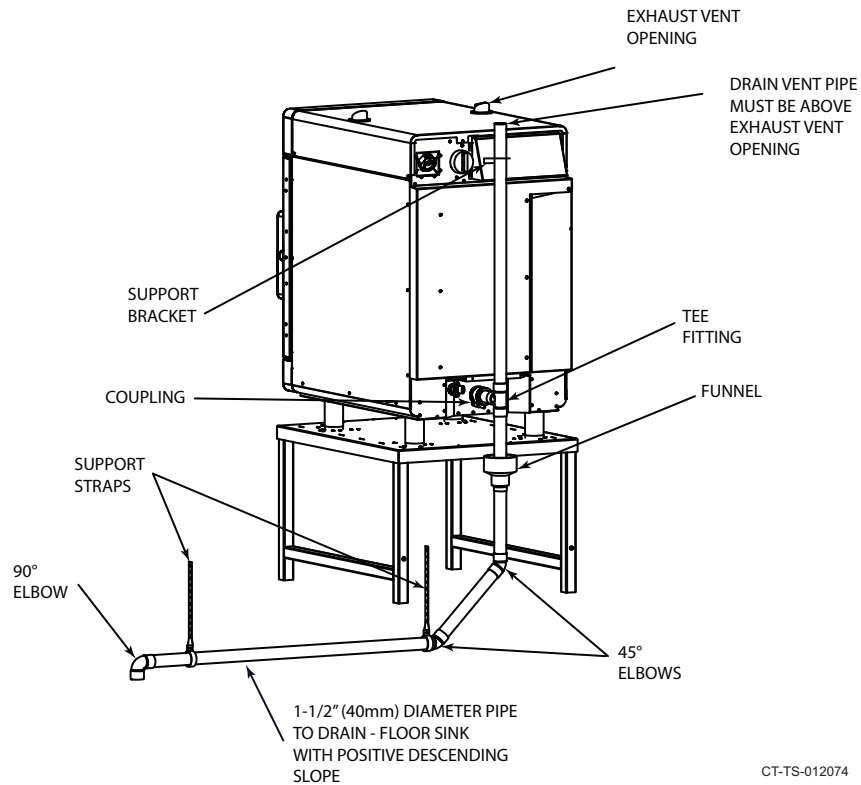

CT-TS-012074

Continued on next page

Continued from previous page

To install the water drain, do the following.

7. **Drill** a hole for the mounting bracket using the dimensions in the image. **Install** a screw into the drilled hole. Drill a hole for the second mounting screw. Install the screw.

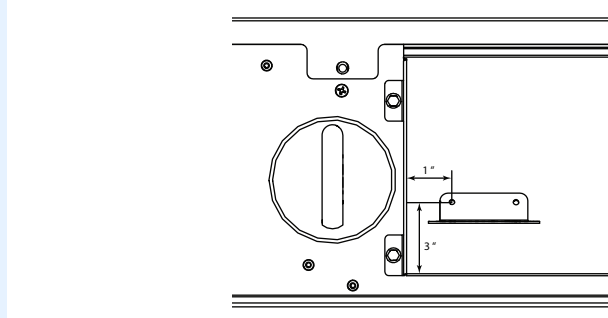

CT-TS-012077

8. **Install** the no hub coupling onto the over drain. **Cut** a short piece of drain pipe. **Install** the pipe into the Tee fitting from the kit. **Install** the pipe and Tee fitting into the no hub coupling.

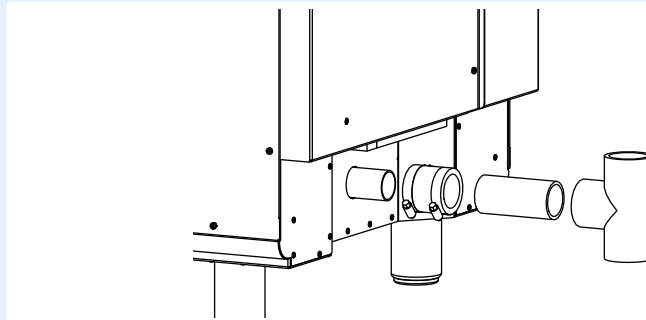

CT-TS-012080

9. **Install** the vent pipe into the Tee fitting.

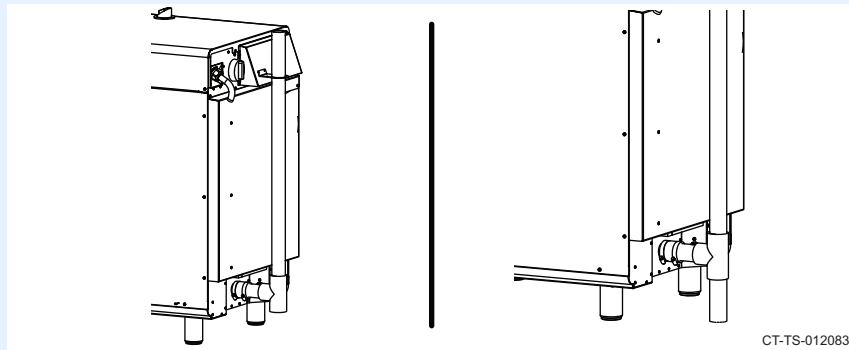

CT-TS-012083

Continued on next page

Continued from previous page

10. **Install** the remaining drain pipe.
Secure the drain with the clamps from the kit.

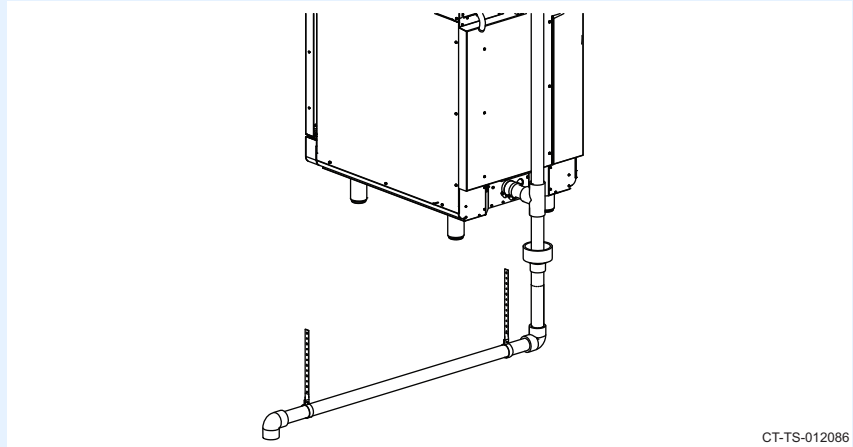

Result

The water supply and drain are now installed.

How to Install the Oven (60 Hz Cord and Plug Models)

Before you begin

Make sure you have:

- An appropriate lifting device, and enough personnel, to safely move and position the weight of the oven.
 - CMC-H2H: 304 lb (138 kg)
 - CMC-H3H: 394 lb (179 kg)

Requirements

- The oven must be installed on a level surface.
- The oven must not be installed in any area where it may be affected by steam, grease, dripping water, high temperature, or any other severely adverse conditions.
- The oven is not intended for built-in installation.

Voltages

	V	Ph	Hz	A	Breaker*	kW	Plug Configuration**
CMC-H2H	208	1	60	32	50	6.7	NEMA 6-50P
	240	1	60	37	50	8.9	NEMA 6-50P
	208	3	60	19	30	6.7	NEMA 15-30
	240	3	60	22	30	8.9	NEMA 15-30
CMC-H3H	208	3	60	28	50	10.1	
	240	3	60	32	50	13.4	

*Electrical connections must meet all applicable federal, state, and local codes.

**For use on individual circuit branch only.

Continued on next page

Continued from previous page

Position the oven

To position the oven, do the following.

Step	Action
1.	<p>Make sure that:</p> <ul style="list-style-type: none"> ■ The location where the oven is being installed is rated to support the weight of the oven; ■ The oven is within five feet (1.5m) of the appropriate electrical outlet; ■ You follow the oven clearance guidelines.
	
2.	<p>Move the oven to the installation location and onto the final resting surface.</p>

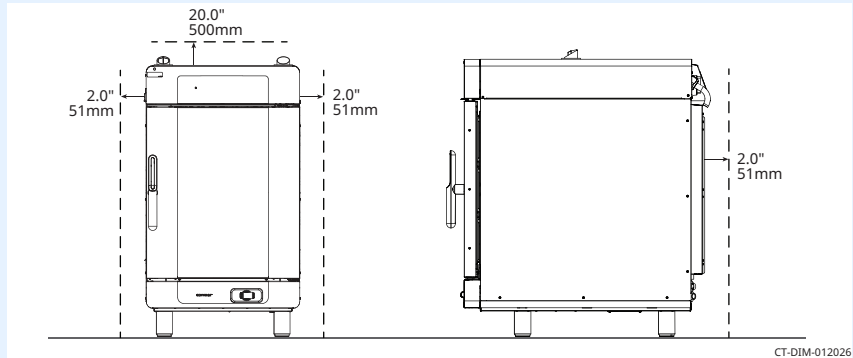

CT-DIM-012026

The oven is now correctly positioned.

Level the oven

To level the oven, do the following.

3. **Check** the level of the oven using a spirit (bubble) level. Check front to back and side to side.

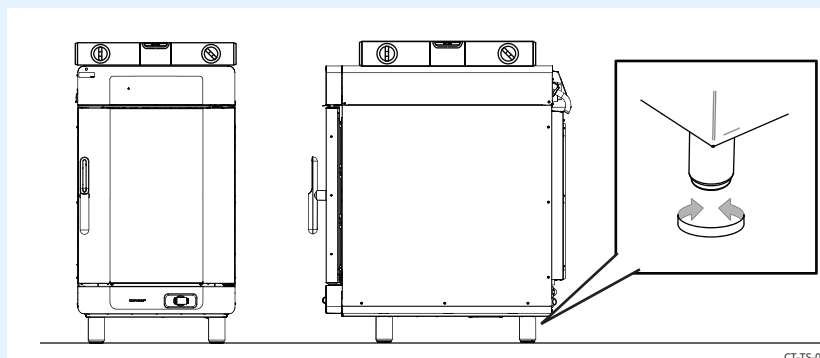

CT-TS-012029

Adjust the legs, if necessary, to achieve levelness.

The oven is now correctly positioned.

Continued on next page

Continued from previous page

Connect power

To connect electric power to the oven, do the following.

4. **Set** the main disconnect switch ① to the OFF position.

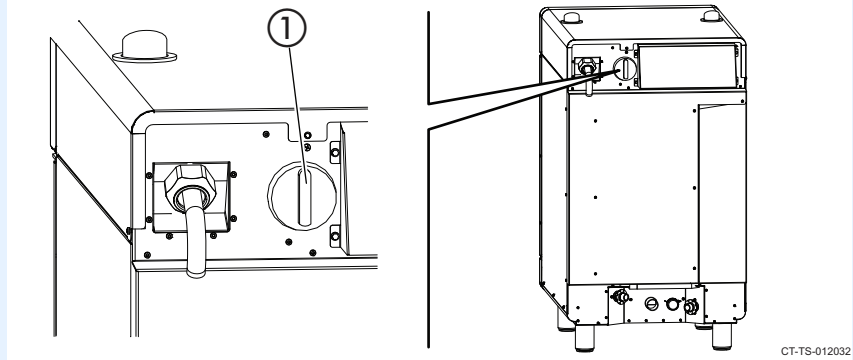

5. **Connect** the plug to the electrical outlet.

Press reset button(s)

6. **Press and release** the high limit temperature reset button(s) ②.

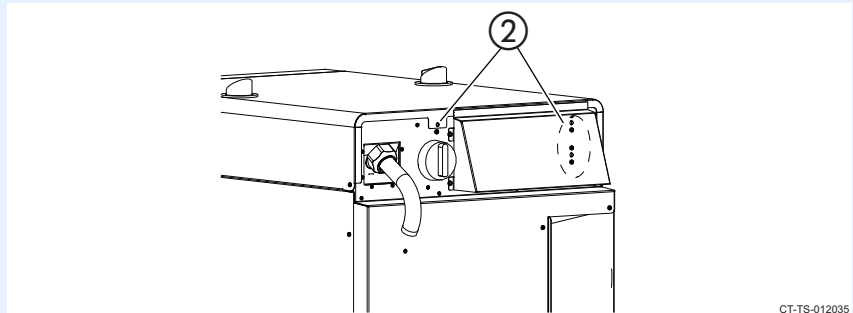

Result

The oven is now installed and ready to be used.

How to Install the Oven

(50 Hz Models Without Cord or Plug)

Before you begin

Make sure you have:

- An appropriate lifting device, and enough personnel, to safely move and position the weight of the oven.
 - CMC-H2H: 304 lb (138 kg)
 - CMC-H3H: 394 lb (179 kg)

Requirements

- The oven must be installed on a level surface.
- The oven must not be installed in any area where it may be affected by steam, grease, dripping water, high temperature, or any other severely adverse conditions.
- The oven is not intended for built-in installation.
- For 3-phase applications, an RCD Type B protection device must be installed. The device must accommodate a leakage current that may exceed 10 mA.
- If a power cord is used for the connection of the product, an oil resistant cord like H05RN or H07RN or equivalent must be used.

Voltages

	V	Ph	Hz	A	Breaker*	kW
CMC-H2H	380	3	50	11	30	7.5
	415	3	50	12	30	8.9
CMC-H3H	380	3	50	17	50	11.3
	415	3	50	19	50	13.4

*Electrical connections must meet all applicable federal, state, and local codes.

Continued on next page

Continued from previous page

Wire sizes

60335-1 IEC:2010

Rated current of appliance A	Nominal cross-sectional area mm ²
>0.2 - ≤3	0.5
>3 - ≤0	0.75
>6 - ≤10	1.0
>10 - ≤16	1.5
>16 - ≤25	2.5
>25 - ≤32	4
>32 - ≤40	6
>40 - ≤63	10

Position the oven

To position the oven, do the following.

Step	Action
1.	<p>Make sure that:</p> <ul style="list-style-type: none"> ■ The location where the oven is being installed is rated to support the weight of the oven; ■ The oven is within five feet (1.5m) of the appropriate electrical outlet; ■ You follow the oven clearance guidelines.
	<p style="text-align: right; font-size: small;">CT-DIM-012026</p>
2.	<p>Move the oven to the installation location and onto the final resting surface.</p>

The oven is now correctly positioned.

Continued on next page

Continued from previous page

Level the oven

To level the oven, do the following.

3. **Check** the level of the oven using a spirit (bubble) level. Check front to back and side to side.

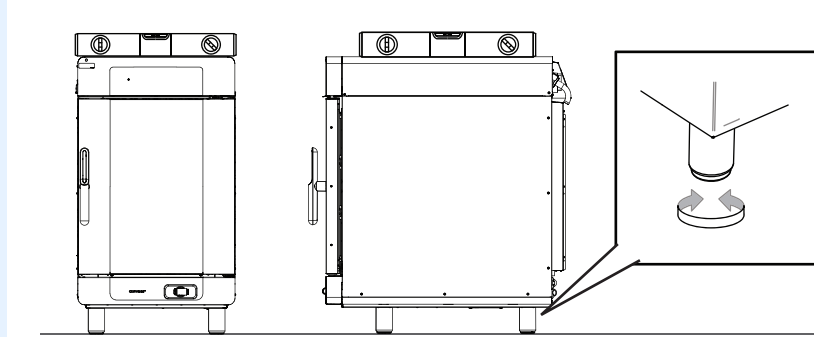

CT-TS-012029

Adjust the legs, if necessary, to achieve levelness.

The oven is now correctly positioned.

Connect the wiring

To connect the wiring, do the following.

4. **Remove** the pivot screws. **Remove** the top cover ①.



WARNING: Electric shock hazard.

Make sure the supply cord is not connected to a power supply.

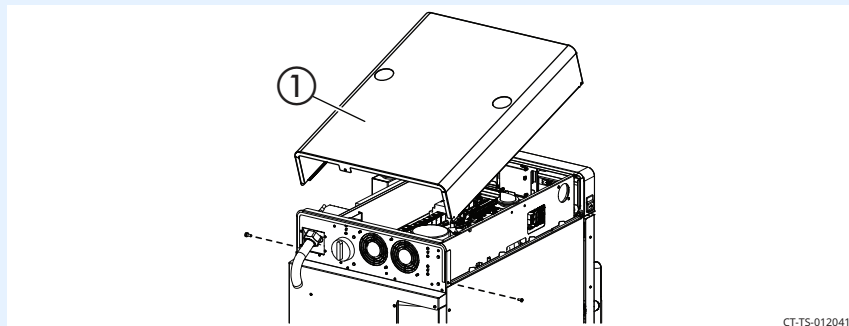

CT-TS-012041

Continued on next page

Continued from previous page

5. **Remove** the bottom 3 screws ② from the mounting bracket.
Remove the main disconnect switch ③ from the mounting bracket.

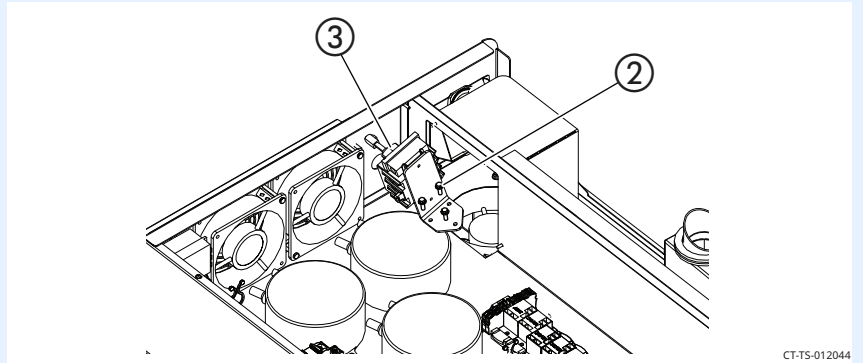

6. **Install** the cord ④ through the cord grip ⑤ and install in the oven.
- Install** the lock nut onto the cord grip.

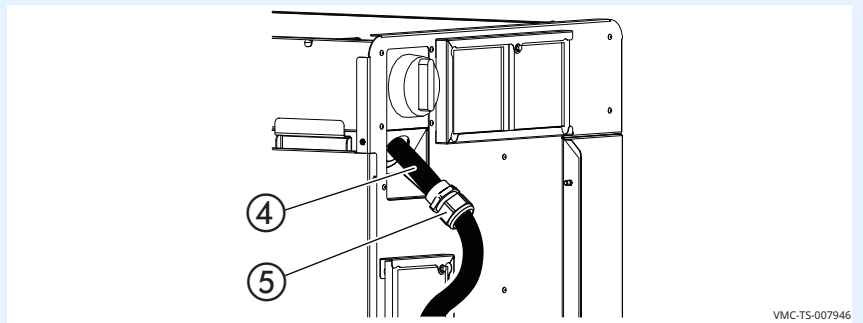

Continued on next page

Continued from previous page

7. **Connect** the supply cord to the appropriate terminals (L1, L2, L3, etc.) in accordance with local codes and regulations.

Install the ground wire ⑥.

Leave an extra loop ⑦ so that current-carrying conductors become taut before the ground wire if the cord is accidentally pulled. Follow applicable regulations.

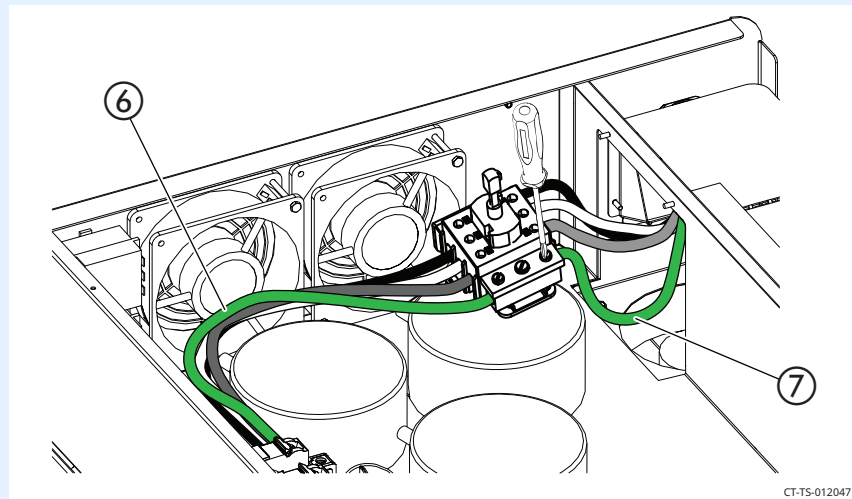

8. **Re-install** the main disconnect switch.
9. **Re-install** the mounting bracket.
10. **Re-install** the top cover.

Press reset button(s)

11. **Press and release** the high limit temperature reset button(s) ⑧.

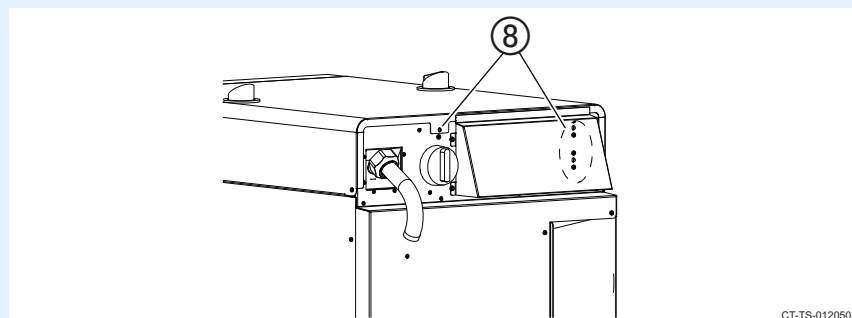

Result

The oven is now installed and ready to be used.

How to Install the Oven on a Stand

Before you begin

Make sure you have:

- The appropriate stand for your oven
- Regulation UL 197, 91.8
- A pop rivet gun and rivets
- An appropriate lifting device, and enough personnel, to safely move and position the weight of the oven.
 - CMC-H2H: 304 lb (138 kg)
 - CMC-H3H: 394 lb (179 kg)

Procedure

To install the ovens on a stand, do the following.

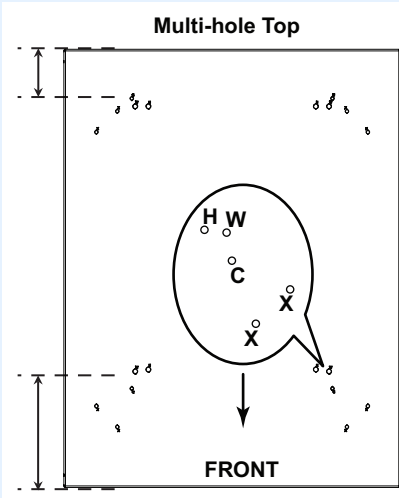
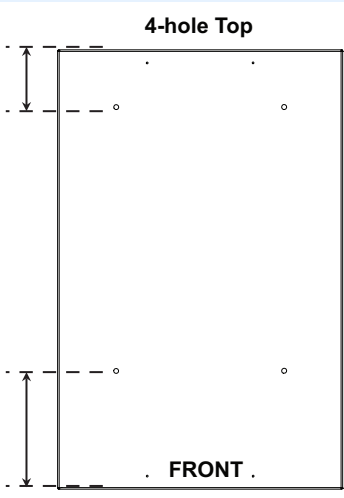
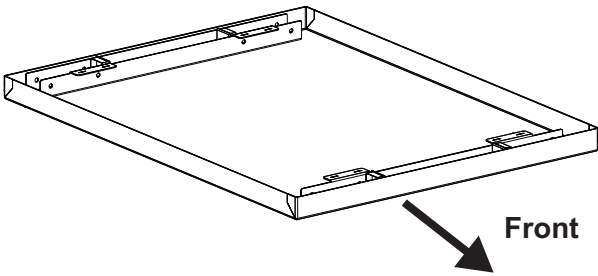
Step	Action
1.	<p>Locate the front of the top panel.</p> <div style="display: flex; justify-content: space-around;"> <div style="text-align: center;"> <p>Multi-hole Top</p>  </div> <div style="text-align: center;"> <p>4-hole Top</p>  </div> </div> <p style="text-align: right; font-size: small;">VMC-TS-012917</p>
2.	<p>Put the top upside down on a flat surface.</p> <div style="text-align: center;">  </div> <p style="text-align: right; font-size: small;">VMC-TS-012920</p>

Continued on next page

Continued from previous page

3. **Install** the leg assembly into the top panel.

Attach the leg assembly to the top panel with bolts and lock washers.

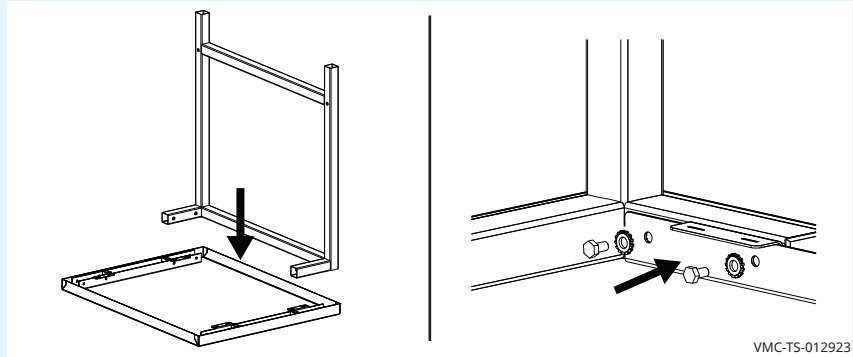

4. **Install** the second leg assembly into the top panel.

Attach the leg assembly to the top panel with bolts and lock washers.

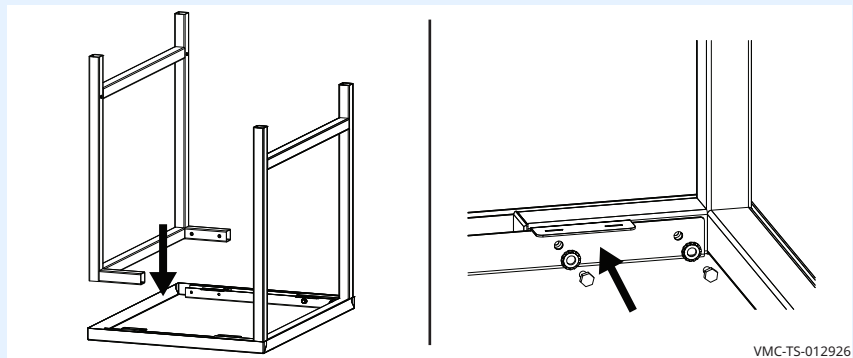

5. **Install** the casters or the feet assemblies into the legs.

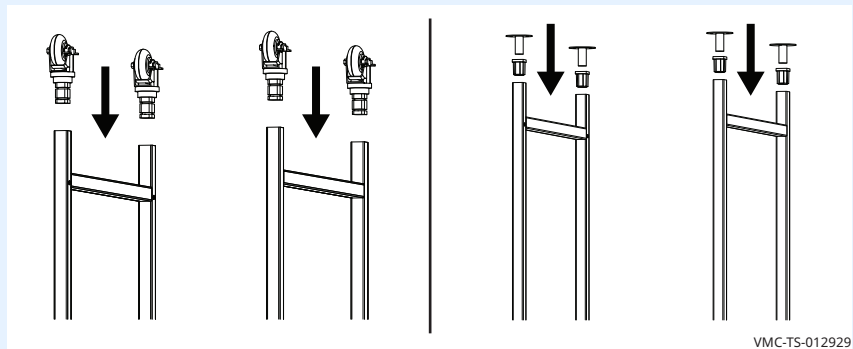

Continued on next page

Continued from previous page

Installing the shelf (optional)

6. **Determine** which way the slots are to be oriented.

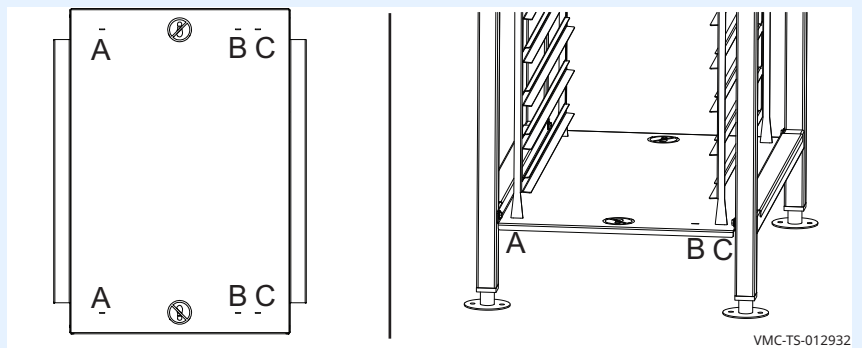

7. **Install** the shelf onto the leg assemblies.
Attach the shelf to the leg assemblies with bolts and lock washers.

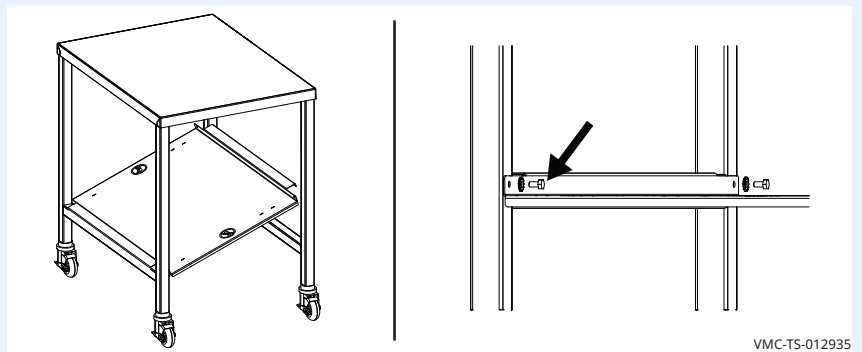

Installing the racks (optional)

8. **Install** the rack into the slots on the underside of the top.

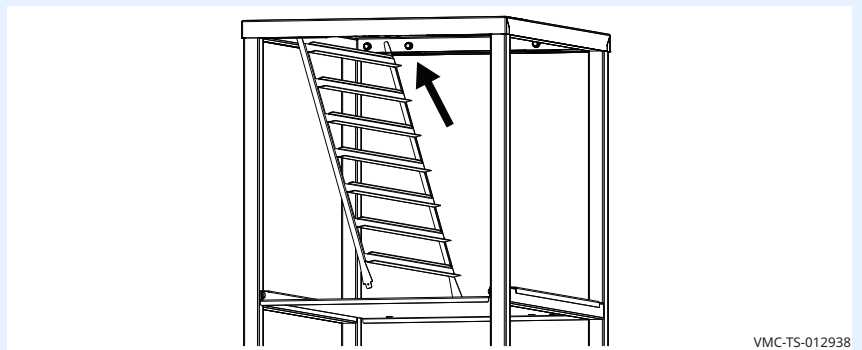

Continued on next page

Continued from previous page

9. **Rotate** the rack and lower it into the slots on the shelf.
Attach the rack to the shelf with cotter pins.



NOTE: Expand the cotter pin after inserting it through the hole.

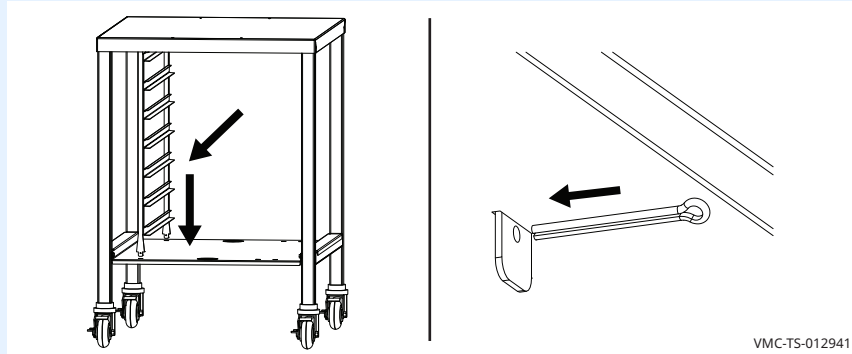

VMC-TS-012941

10. **Repeat** the process for the other rack.

11. **Locate** the holes in the top of the stand with the letter "C" etched next to them.

Installing the support channels

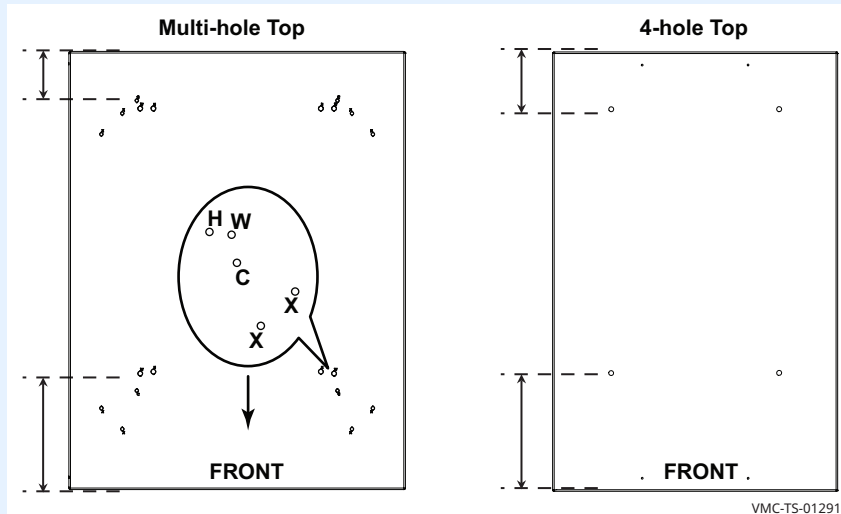

VMC-TS-012917

Continued on next page

Continued from previous page

12. **Place** the support channels onto the top of the stand. Line up the holes in the channels with the holes in the top of the stand.

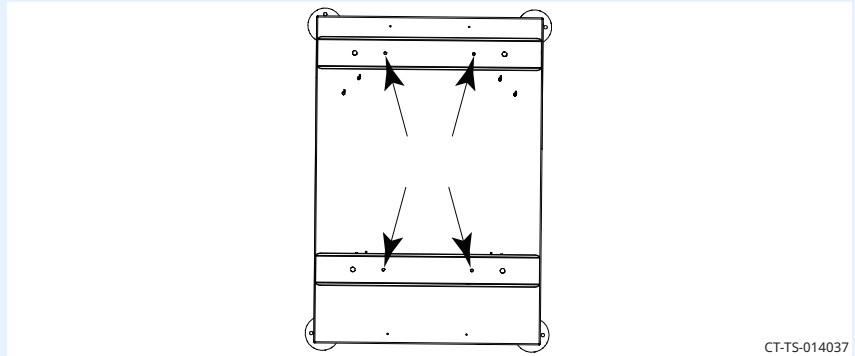

CT-TS-014037

13. **Rivet** the channels to the top of the stand.

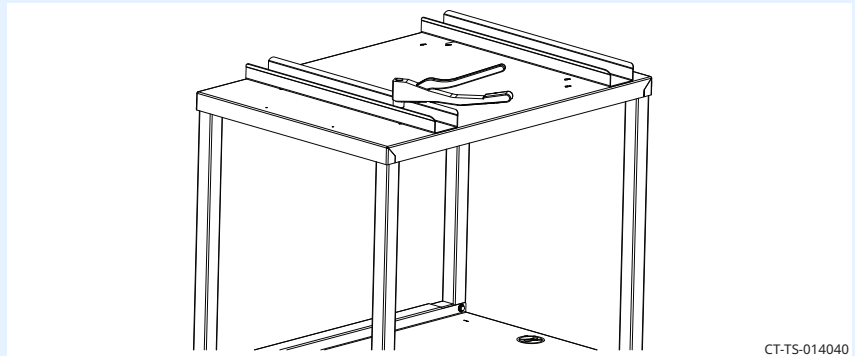

CT-TS-014040

14. **Install** the pins through the channels and the top of the stand. **Secure** the pins with nuts.

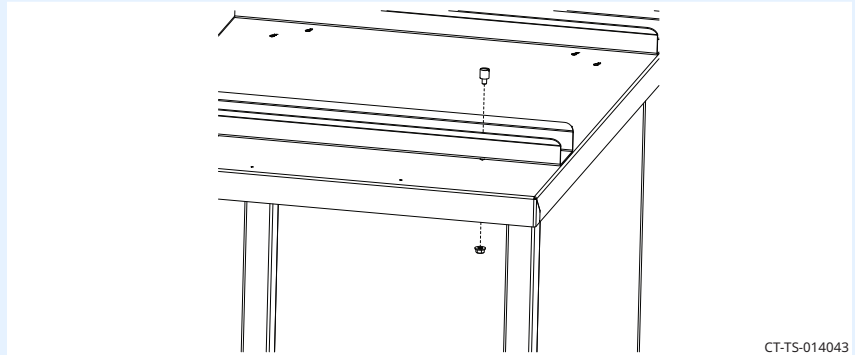

CT-TS-014043

Continued on next page

Continued from previous page

Installing the oven on a stand

15. **Lift** the oven using an appropriate lifting device.

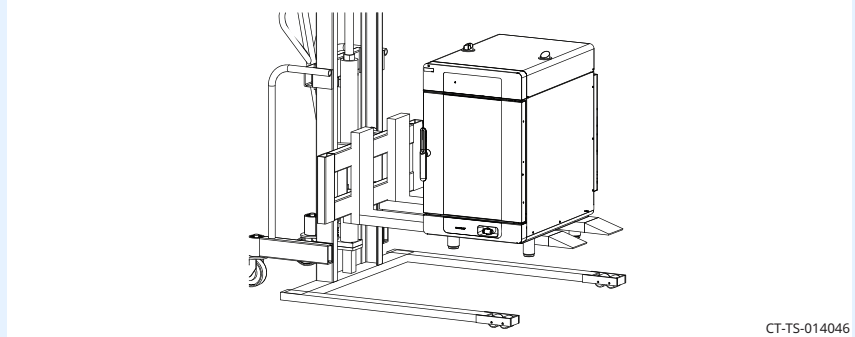

16. **Place** the oven on the stand. Position legs on the outside of the pins.

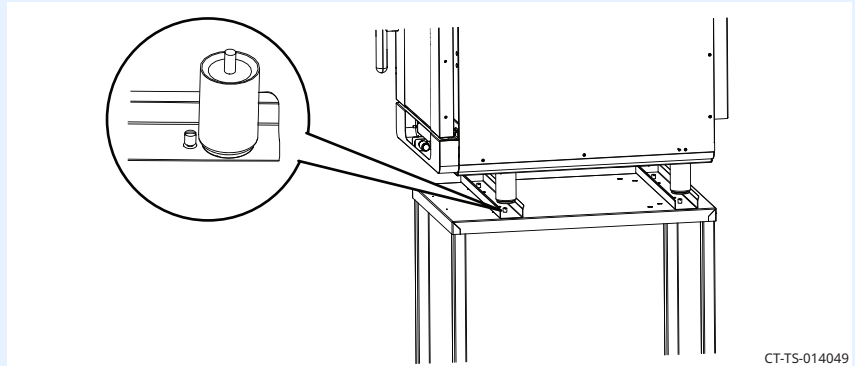

Result

The oven is now installed to the stand.

How to Install Ovens that have Hoods

Background

Ovens that have hoods must be installed on a counter top, on a stand designed for this application, or on a stand that is attached to the building's floor.

Before you begin

Make sure you have:

- The appropriate stand for your oven.
- The appropriate screws to attach the oven to the supporting surface.

Warning



WARNING: Crush hazard.

Converge ovens that have hoods may tip if installed on incorrect stands or on a stand that is not attached to the building's floor.

When installing Converge ovens that have hoods obey the limitations below.

Do not install Converge ovens that have hoods onto stands that have casters.

All IEC/EN certified Converge ovens that have hoods must be attached to the supporting surface.

Limitations

When installing Converge ovens that have hoods obey the limitations below.

- Do not install Converge ovens that have hoods onto stands that have casters.
- Only use stands that have feet supplied by Alto-Shaam.

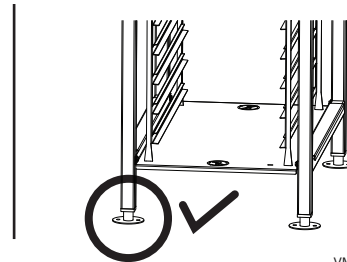
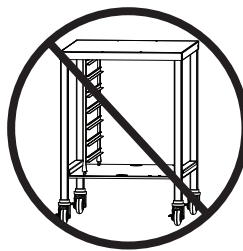

VMC-TS-017398

Permitted stands

The permitted stands are the following:

Stand Width	Maximum height without needing to be attached to floor (All other must be attached to building's floor.)
23" (584mm)	20.5" (521mm)
25.5" (648mm)	30.75" (781mm)
29.5" (749mm)	37.75" (958mm)

How to Install the Jet Plates

Background

Each jet plate assembly consists of one inner panel and one outer panel. There are two unique jet plate assemblies used on the Converge oven. The difference is in the outer panel used. One type (5034275) is used on the lower section of each chamber. The other type (5029717) is used on the upper section of each chamber. The inner panels used are the same for both types of assemblies.

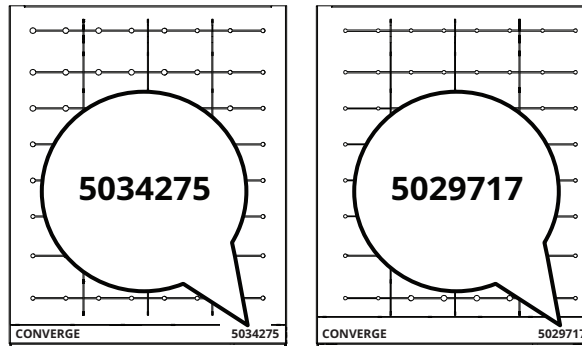

CT-TS-016595

Procedure

To install the jet plates, do the following.

Step	Action
1.	Each outer panel has the part number etched into the right corner. Locate the part number on all outer panels. Place an outer panel on a table with the part number facing up.

CT-TS-016599

Continued on next page

Continued from previous page

2. **Place** an inner panel on the table with the air deflector up.

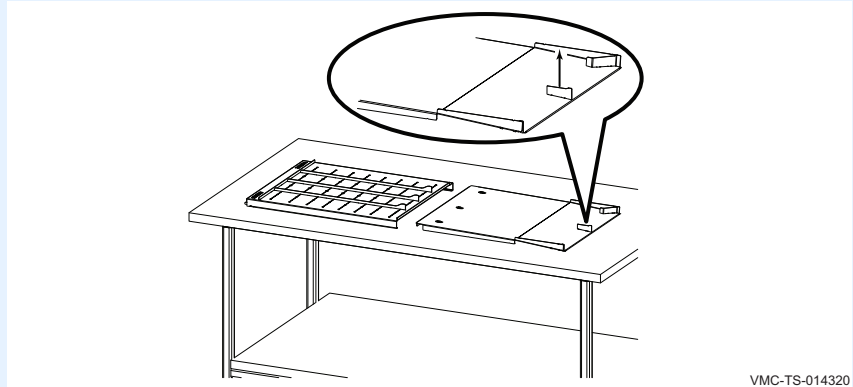

3. **Insert** the inner panel into the outer panel. **Push** the inner panel into the outer panel until it is fully inserted.

Assemble all jet plates in a similar fashion.

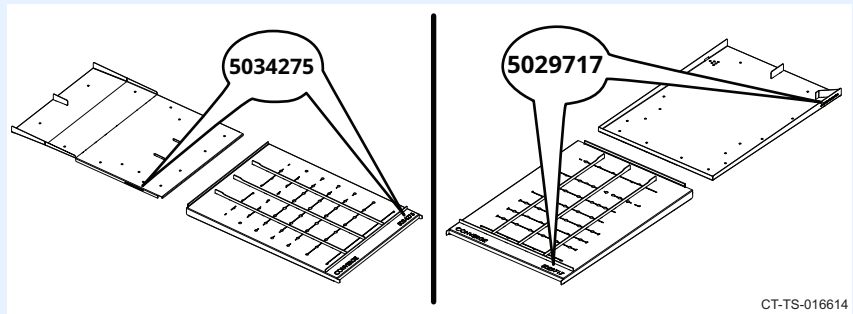

Continued on next page

Continued from previous page

4. **Install** jet plates 5034275 in the lower section of each chamber with the part number facing up. **Install** jet plates 5029717 in the upper section of each chamber with the part number facing down.

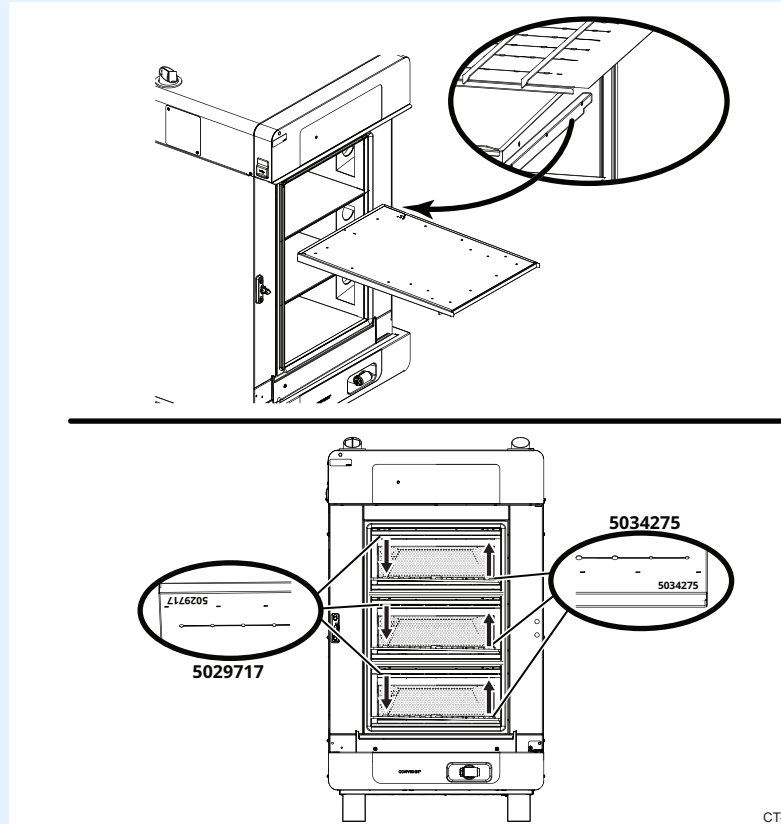

CT-TS-016603

Result

The jet plates are now installed.

How to View and Set up WiFi Connection

Before you begin

- The facility must have WiFi.
- Do not connect to a guest network.

Procedure

To set up WiFi, do the following.

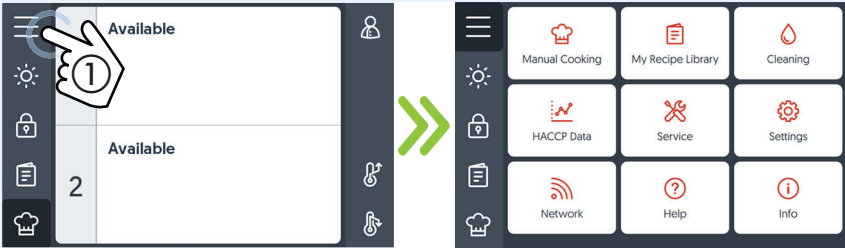
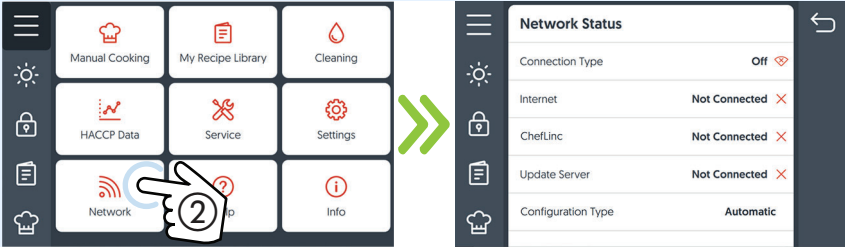
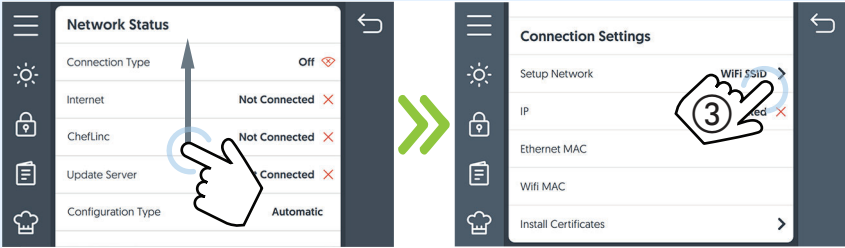
Step	Action
1.	<p>Touch the menu icon ①. The menu screen displays.</p>  <p style="text-align: right; font-size: small;">CT-TS-013849</p>
2.	<p>Touch the “Network” icon ②. The “Network Status” screen displays.</p>  <p style="text-align: right; font-size: small;">CT-TS-013912</p>
3.	<p>Scroll to “Connection Settings”. Touch the “Setup Network” setting ③.</p>  <p style="text-align: right; font-size: small;">CT-TS-013915</p>

Continued on next page

Continued from previous page

4. **Touch** the “WiFi” icon ④.

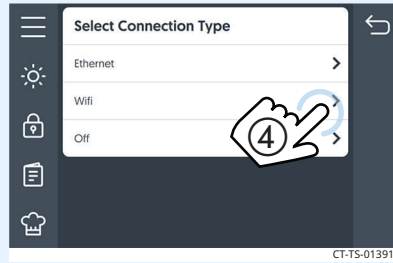

The available networks will show on the screen. The color of the network icon indicates the strength of the signal for each network.

Green = strong
 Yellow = medium
 Red = weak

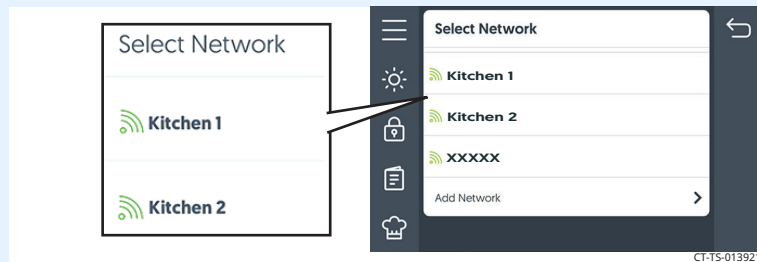

5. If the network is not displayed, **touch** the “Add Network” setting ⑤.

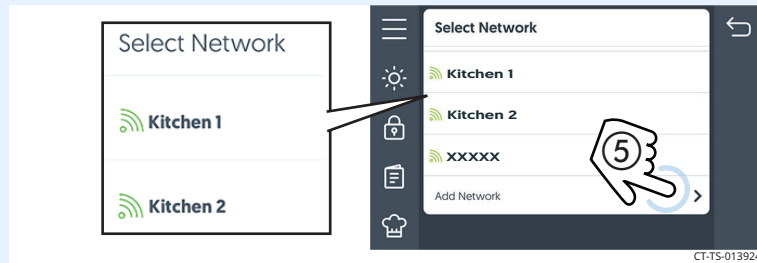

Enter the SSID using the keypad. Then, **touch** the check mark.

Select the security type.

Enter the password using the keypad. Then, **touch** the check mark.

Continued on next page

Continued from previous page

Automatic IP configuration

6. For automatic IP configuration, **touch** the check mark ⑥.

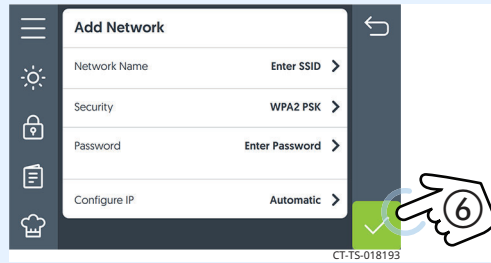

Manual IP configuration

7. For manual IP configuration, **touch** the “Configure IP” setting ⑦. **Touch** “Manual” ⑧ and follow the prompts.

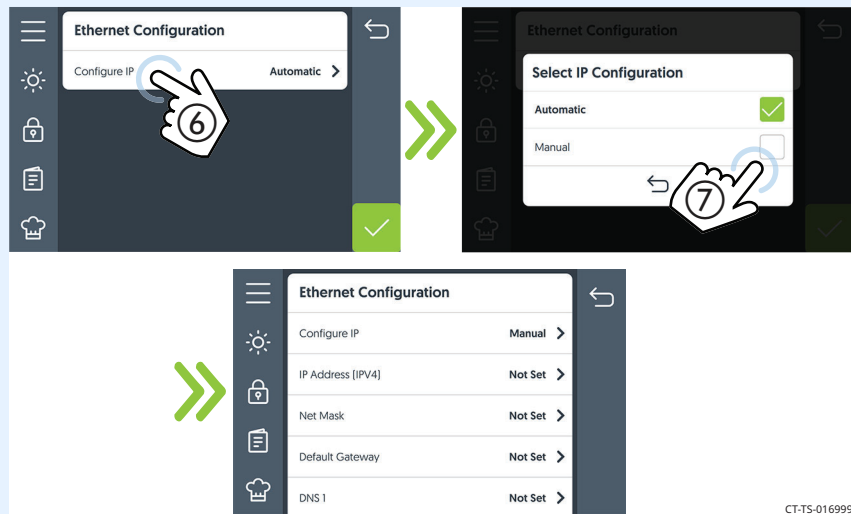

8. **Touch** the check mark when finished.

NOTE: If there are connection problems, touch the “ChefLinc” setting to address ChefLinc connectivity. For server connection issues, touch the “Update Server” setting.

Result

The procedure is now complete.

How to Set up an Ethernet Connection

Before you begin

- The facility must have an Ethernet port.
- You will need an Ethernet cable.

Procedure

To set up an Ethernet connection, do the following.

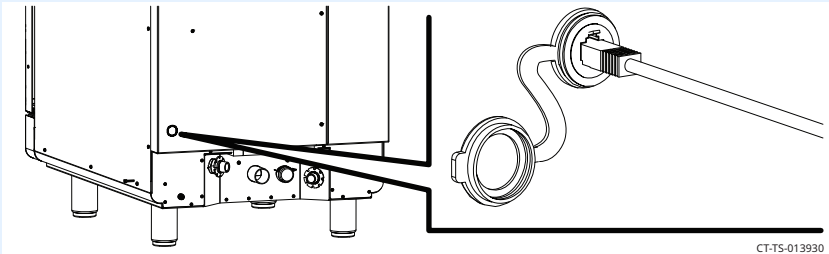
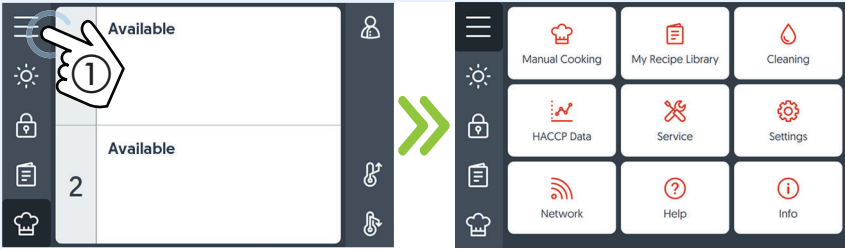
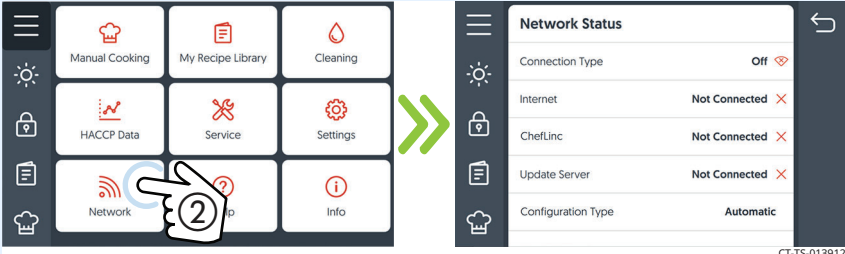
Step	Action
1.	<p>Plug the Ethernet cord into the Ethernet port on the oven and the wall outlet.</p>  <p style="text-align: right; font-size: small;">CT-TS-013930</p>
2.	<p>Touch the menu icon ①. The menu screen displays.</p>  <p style="text-align: right; font-size: small;">CT-TS-013849</p>
3.	<p>Touch the "Network" icon ②. The "Network Status" screen displays.</p>  <p style="text-align: right; font-size: small;">CT-TS-013912</p>

Continued on next page

Continued from previous page

4. **Scroll** to “Connection Settings”. **Touch** the “Setup Network” setting ③.

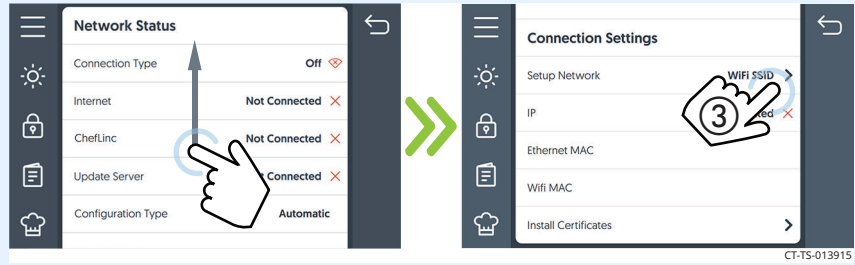

5. **Touch** the “Ethernet” setting ④. The “Ethernet Configuration” screen displays.

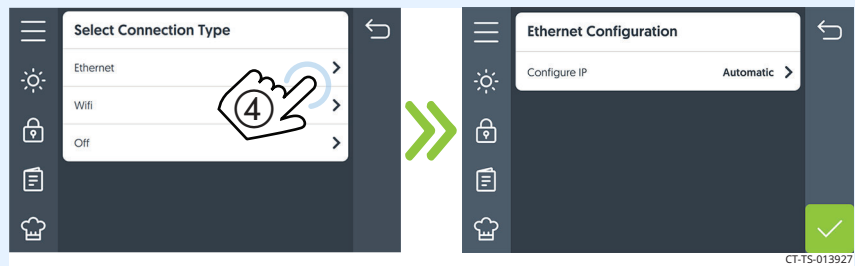

Automatic IP configuration

6. For automatic IP configuration, **touch** the check mark ⑤.

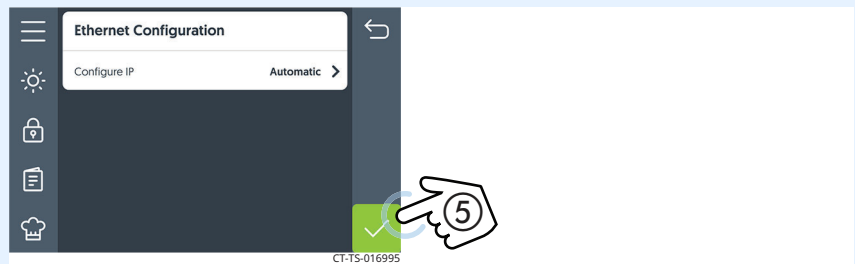

Continued on next page

Continued from previous page

Manual IP configuration

- For manual IP configuration, **touch** the “Configure IP” setting ⑥. **Touch** “Manual” ⑦ and follow the prompts.

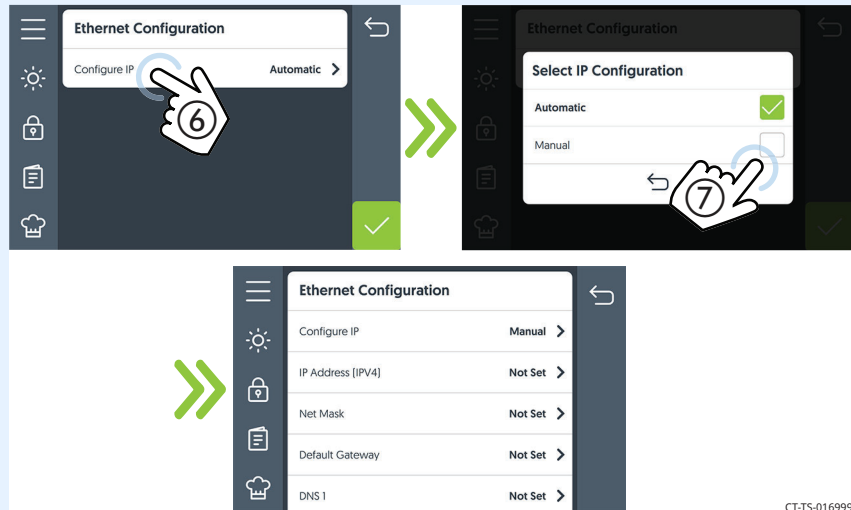

- Touch** the check mark when finished.

NOTE: If there are connection problems, touch the “ChefLinc” setting to address ChefLinc connectivity. For server connection issues, touch the “Update Server” setting.

Result

The Ethernet connection is now set up.

This page is intentionally left blank.

How to Turn On and Turn Off the Oven

Before you begin

The oven must be connected to electric power.

Turning on the oven

To turn on the oven, do the following.

Step	Action
1.	<p>Set the main disconnect switch ① to the ON position.</p> <p>Touch the ON/OFF button ②.</p> <div data-bbox="613 621 1273 711" data-label="Text"> <p>NOTE: The main disconnect switch is meant to be used during service operations. For every day operation, it may be left in the ON position.</p> </div> <div data-bbox="537 739 1385 1083" data-label="Image"> <p>The diagram shows two views of the oven. The left view shows the main disconnect switch (1) on the side panel. The right view shows the ON/OFF button (2) on the control panel, which is an LED button with a power symbol. The reference code CT-TS-011206 is located at the bottom right of the image.</p> </div>
2.	<p>Touch and hold the ON/OFF button ② until the “Shut Down Options” screen displays. Touch “Shut down” ③. The oven activates the blowers for the cool-down process. The cool-down process is complete when the oven deactivates the blowers and the display screen turns off.</p> <div data-bbox="537 1430 1385 1749" data-label="Image"> <p>The diagram shows the control panel of the oven. The ON/OFF button (2) is an LED button with a power symbol. The Shut down button (3) is a button with a power symbol and the text 'Shut down'. A hand is shown touching the Shut down button. The Restart button is also visible. The reference code CT-TS-014018 is located at the bottom right of the image.</p> </div>

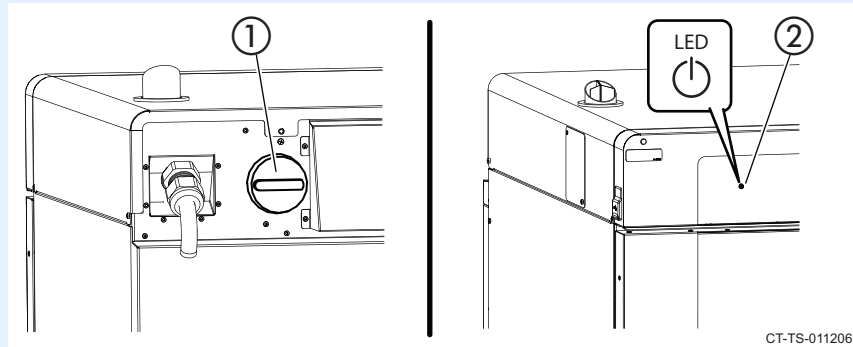

The oven is now on.

Turning off the oven

To turn off the oven, do the following.

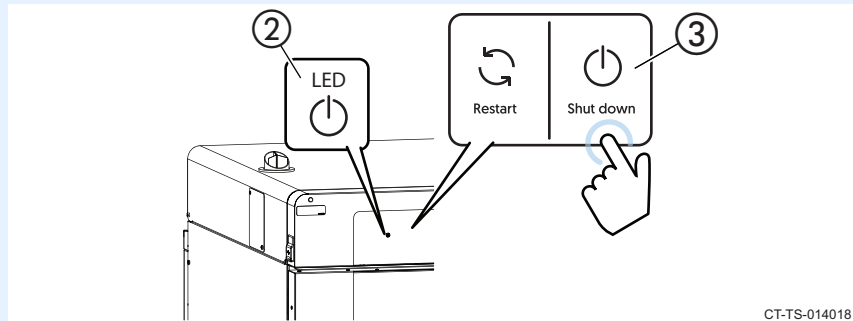

The oven is now off.

How to Preheat the Oven

Before you begin

Make sure:

- The oven is turned on.
- The oven door is closed.

Procedure

To preheat the oven, do the following.

Step	Action
1.	<p>Touch the menu icon ①. The menu screen displays.</p>  <p style="text-align: right; font-size: small;">CT-TS-013849</p>
2.	<p>Touch the “Settings” icon ②. The “General Settings” screen displays.</p>  <p style="text-align: right; font-size: small;">CT-TS-013852</p>
3.	<p>Scroll to the “Temperature Settings.”</p> <p>Touch the “Default Preheat Temps” icon ③. The “Set Preheat Temps” screen displays.</p>  <p style="text-align: right; font-size: small;">CT-TS-012011</p>

Continued on next page

Continued from previous page

4. **Touch** the preheat chamber setting for the chamber to be used ④. **Enter** the preheat temperature using the number pad. **Touch** the check mark. **Repeat** with remaining chambers



CT-TS-018565

5. **Touch** the check mark ⑤. **Touch** the check mark ⑥ to return to the menu screen.

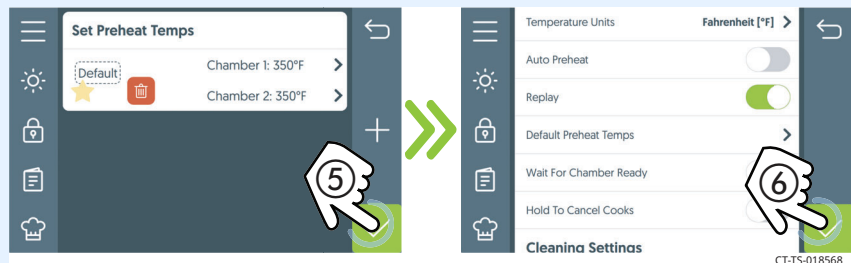

CT-TS-018568

6. **Touch** the manual cook icon ⑦. The manual cook screen displays.



CT-TS-018571

7. **Touch** the preheat icon ⑧. The preheat confirmation screen displays. **Touch** "Preheat" ⑨. All chambers start to preheat to their preset temperatures.

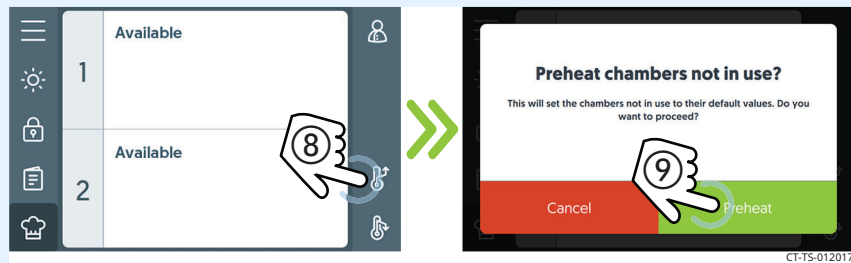

CT-TS-012017

Continued on next page

Continued from previous page

Screen loading bars

Loading bars indicate each chamber's progress towards reaching its set temperature.

If necessary, touch the cancel icon **10** to cancel the preheating process before the individual chamber reaches its preset preheat temperature. Each chamber must be canceled individually.

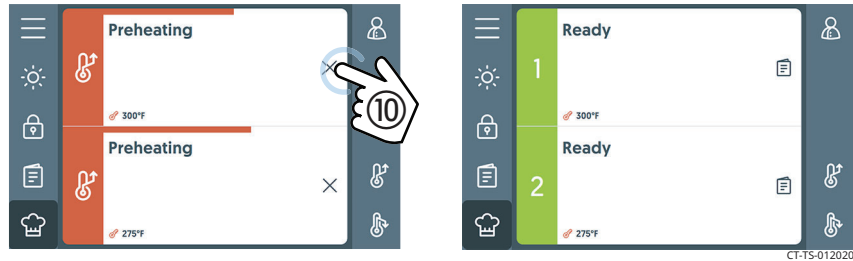

Result

The oven is preheating. When the preheat process is complete, the screen displays "Ready" for each chamber.

How to Preheat the Oven with Multiple Preheat Setpoints

Before you begin

Make sure:

- The oven is turned on.
- The oven door is closed.

Procedure

To preheat the oven with multiple preheat setpoints, do the following.

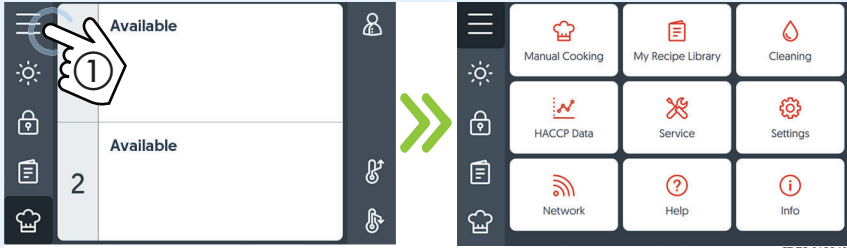
Step	Action
1.	<p>Touch the menu icon ①. The menu screen displays.</p>  <p style="text-align: right;"><small>CT-TS-013849</small></p>
2.	<p>Touch the “Settings” icon ②. The “General Settings” screen displays.</p>  <p style="text-align: right;"><small>CT-TS-013852</small></p>
3.	<p>Scroll to the “Temperature Settings.”</p> <p>Touch the “Default Preheat Temps” icon ③. The “Set Preheat Temps” screen displays.</p>  <p style="text-align: right;"><small>CT-TS-012011</small></p>

Continued on next page

Continued from previous page

Preset group 1

4. **Touch** the preheat chamber setting for the chamber to be used **④**. **Enter** the preheat temperature using the number pad. **Touch** the check mark. **Repeat** for remaining chambers.

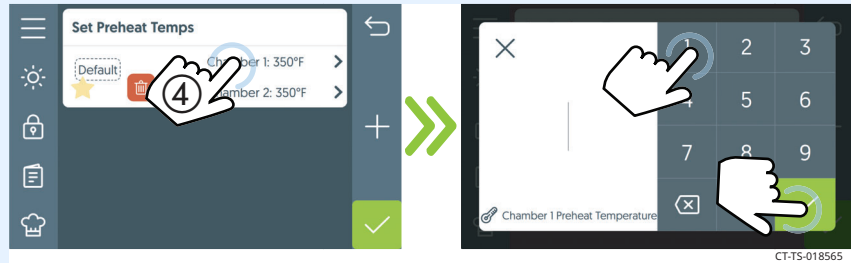

CT-TS-018565

5. **Touch** the plus sign icon **⑤**. **Enter** a new name for the preset by using the keypad. **Touch** the check mark.



CT-TS-018657

Preset group 2

6. **Touch** the preheat chamber setting for the chamber to be used **⑥**. **Enter** the preheat temperature using the number pad. **Touch** the check mark. **Repeat** for remaining chambers.

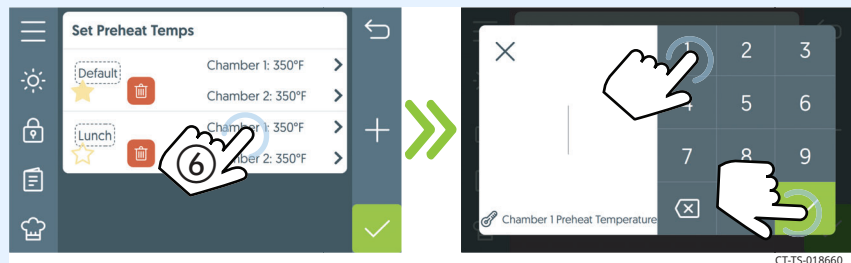

CT-TS-018660

Continued on next page

Continued from previous page

7. **Touch** the “default” icon ⑦.

Enter a new name for the preset by using the keypad. **Touch** the check mark.

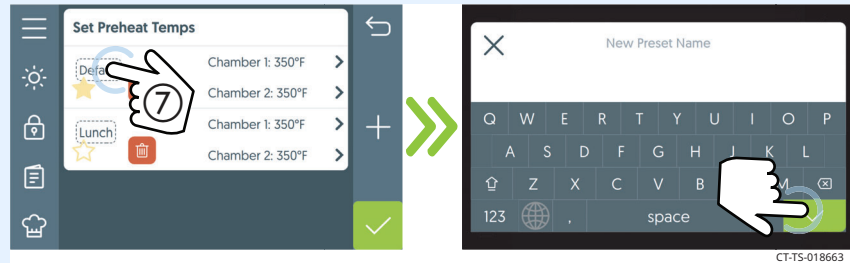

CT-TS-018663

8. **Repeat** steps 5 and 6 if a third group of preheat presets is needed. A maximum of three preset groups can be used.

9. **Touch** the star icon ⑧ of the preset you want to set as the default for auto preheat.

Touch the check mark ⑨.

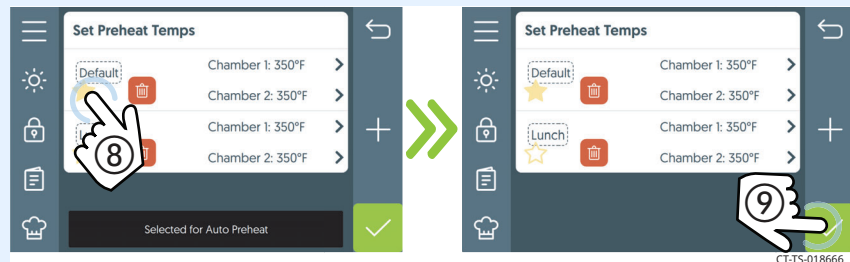

CT-TS-018666

10. **Touch** the check mark ⑩.

Touch the manual cook icon ⑪ to return to the manual cook screen.



CT-TS-018669

Continued on next page

Continued from previous page

11. **Touch** the preheat icon ⑫. The “Select Preheat Temperatures” screen displays.

Touch desired preheat setting ⑬. All chambers start to preheat to their preset temperatures.

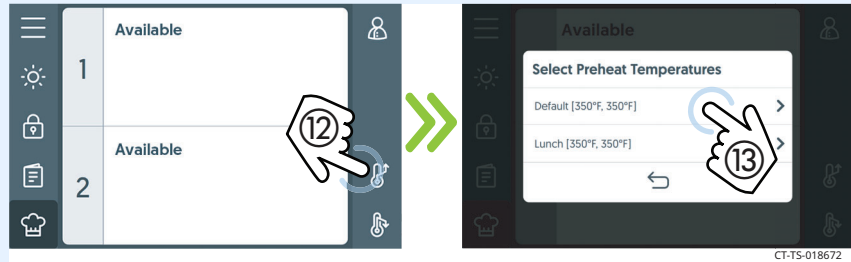

CT-TS-018672

Screen loading bars

Loading bars indicate each chamber’s progress towards reaching its set temperature.

If necessary, touch the cancel icon ⑭ to cancel the preheating process before the individual chamber reaches its preset preheat temperature. Each chamber must be canceled individually.

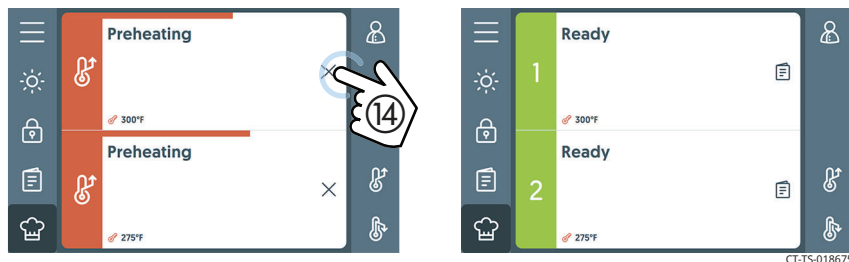

CT-TS-018675

Result

The oven is preheating. When the preheat process is complete, the screen displays “Ready” for each chamber.

How to Cook with Programmed Recipes

Before you begin

Make sure:

- The oven is preheated.
- Your food is prepared and ready to cook.

Procedure

To cook using a programmed recipe, do the following.

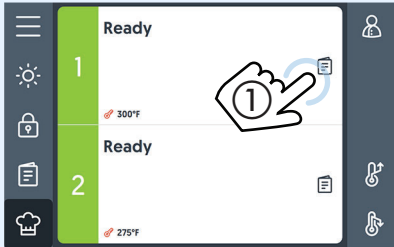
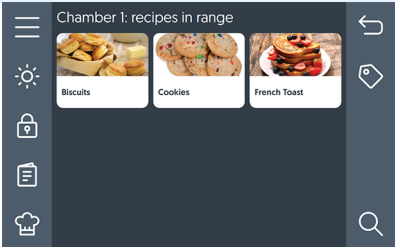
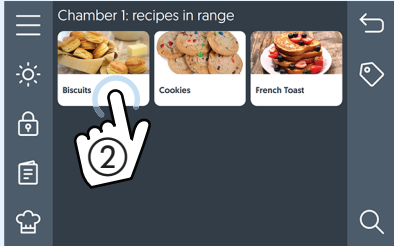
Step	Action
1.	<p>Touch the recipe book icon ① for the desired chamber to cook in. The “Chamber 1: recipes in range” screen displays.</p>   <p style="text-align: right; font-size: small;">CT-TS-018050</p>
2.	<p>Navigate to the recipe. Touch the recipe ②.</p>  <p style="text-align: right; font-size: small;">CT-TS-013982</p>
3.	<p>Open the door and load the food into the chamber. Close the door.</p>

Continued on next page

Continued from previous page

During the cooking process

The cooking status screen displays the details on the current cook setting.

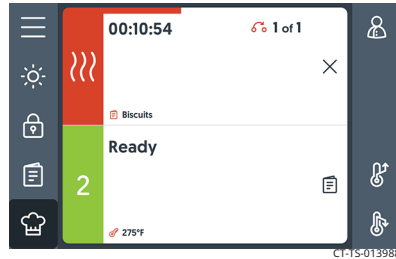

During the cooking process:

Action	Result
Touch the hand icon  when action is required...	to continue the cooking process.
Touch the chamber...	to show the recipe details.
Touch and hold the chamber number...	to show the current chamber temperature.
Touch "X"...	to cancel the cooking process.

Result

At the end of the cooking process, the oven sounds an alert, and the chamber light flashes. Remove the cooked food.

 **NOTE:** Be sure to remove the cooked food after the cooking process is complete. The oven will revert back to the preheat temperature. If left inside the oven, the food will continue to cook.

How to Cook in Manual Mode

Before you begin

Make sure:

- The oven is preheated.
- Your food is prepared and ready to cook.

Background

This procedure consists of:

- setting the food loading action;
- and setting the cooking stage parameters (temperature, time, humidity, and fan speed).

Procedure

To cook in manual mode, do the following.

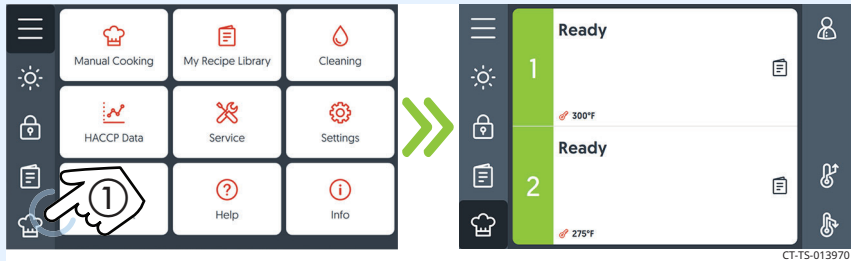
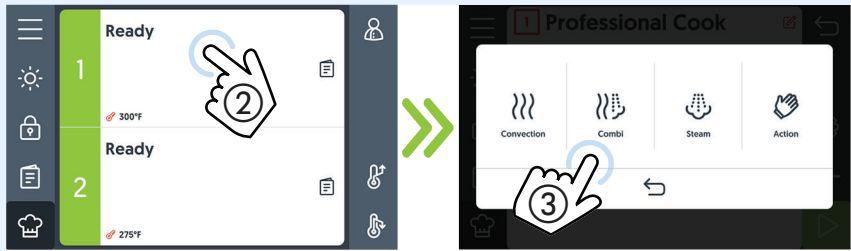
Step	Action
1.	<p>Touch the manual cook icon ①. The available chambers are displayed.</p>  <p>CT-TS-013970</p>
2.	<p>Touch any available chamber ②.</p> <p>Touch a cooking mode or an action step icon ③ to choose the step type.</p>  <p>CT-TS-013991</p>
	<p>NOTE: Touching "Action" adds an action step to the recipe. An action adds manual tasks to be completed during the recipe such as loading the food or adding an ingredient.</p>

Continued on next page

Continued from previous page

- The "Manual Cook" screen displays. The upcoming steps set the parameters for this screen.

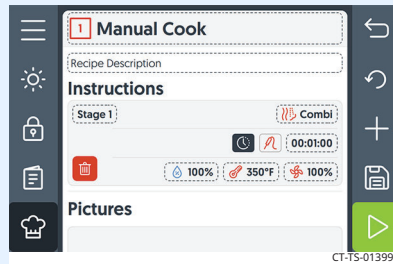

Cooking by time

- If cooking by time, **touch** the cook by time icon (4). Then, **touch** the cooking time (5). **Enter** the cooking time using the key pad. **Touch** the check mark.

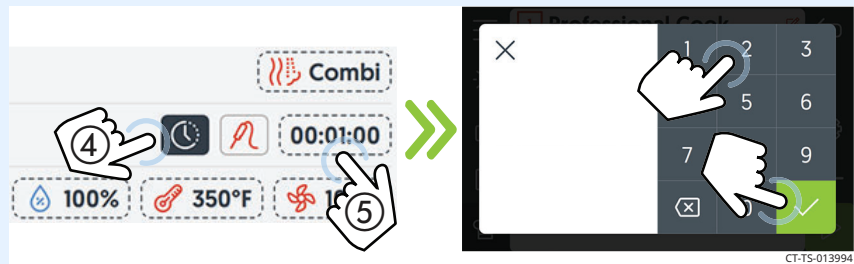

Cooking by probe

- If cooking by probe, **touch** the cook by probe icon (6). Then, **touch** the probe temperature (7). **Enter** the probe temperature set-point using the key pad. **Touch** the check mark.



Continued on next page

Continued from previous page

6. **Touch** the cooking temperature icon ⑧. **Enter** the cooking temperature using the key pad. **Touch** the check mark.
- Touch** the humidity percentage icon ⑨. **Enter** the humidity percentage using the key pad. **Touch** the check mark.
- Touch** the fan speed icon ⑩. **Enter** the fan speed using the key pad. The fan speed can be set in increments of five percent. **Touch** the check mark.

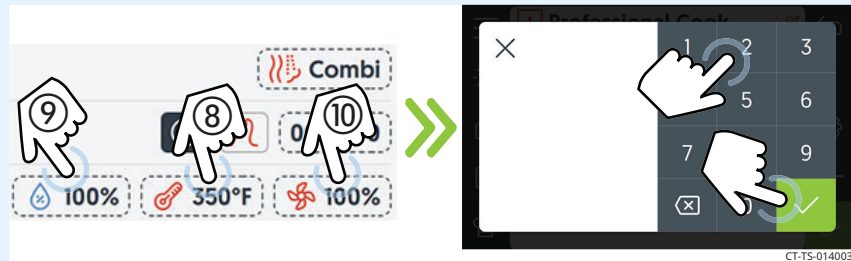

7. **Touch** the plus (+) icon ⑪ to add an additional step or action, if needed.
8. **Load** the food into the appropriate chamber.
9. **Touch** the start icon ⑫. The cooking process timer starts to count down.

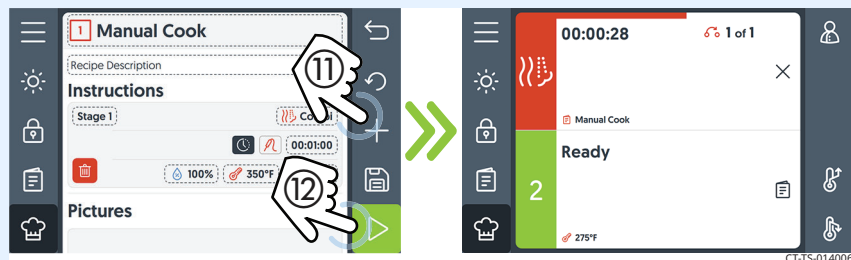

During the cooking process

Action	Result
Touch the hand icon  when action is required...	to continue the cooking process.
Touch the chamber...	to show the recipe details.
Touch and hold the chamber number...	to show the current chamber temperature.
Touch "X"...	to cancel the cooking process.

Continued on next page

Continued from previous page

10. At the end of the cooking process, the oven sounds an alert, and the chamber light flashes.

11. **Open** the door and remove the hot food.



NOTE: Be sure to remove the cooked food after the cooking process is complete. The oven will revert back to the preheat temperature. If left inside the oven, the food will continue to cook.

Result

The food is now cooked.

How to Cook in Professional Mode

Before you begin

Make sure:

- The oven is preheated.
- Your food is prepared and ready to cook.

Background

This procedure consists of:

- setting the food loading action;
- and setting the cooking stage parameters (temperature, time, humidity, and fan speed).

Procedure

To cook in professional mode, do the following.

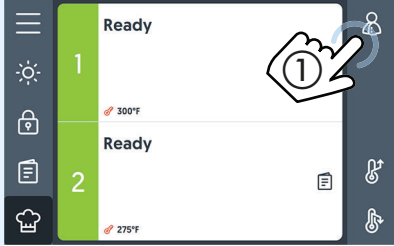
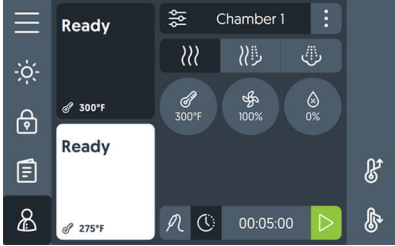
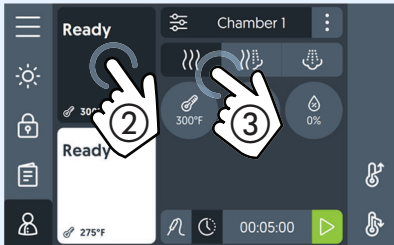
Step	Action
1.	From the manual cooking screen, touch the professional cook icon ①. The available chambers are displayed.
	 
2.	Touch any available chamber ②. Touch a cooking mode ③.
	

Continued on next page

Continued from previous page

Cooking by time

3. If cooking by time, **touch** the cook by time icon ④. Then, **touch** the cooking time ⑤. **Enter** the cooking time using the key pad. **Touch** the check mark.



Continuous cooking

4. To set an indefinite cooking timer, **touch** the continuous cook icon ⑥. **Touch** the check mark.



Cooking by probe

5. If cooking by probe, **touch** the cook by probe icon ⑦. Then, **touch** the probe temperature ⑧. **Enter** the probe temperature set-point using the key pad. **Touch** the check mark.

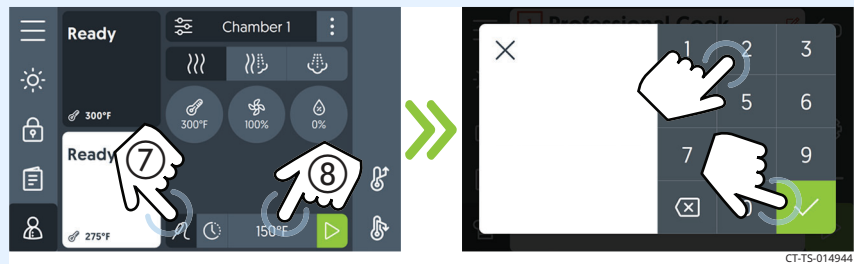

Continued on next page

Continued from previous page

6. **Touch** the cooking temperature ⑨. **Enter** the cooking temperature using the key pad. **Touch** the check mark.
Touch the humidity percentage ⑩. **Enter** the humidity percentage using the key pad. **Touch** the check mark.
Touch the fan speed ⑪. **Enter** the fan speed using the key pad. **Touch** the check mark.



7. **Load** the food into the appropriate chamber.
8. **Touch** the start icon ⑫. The cooking stage timer starts to count down.

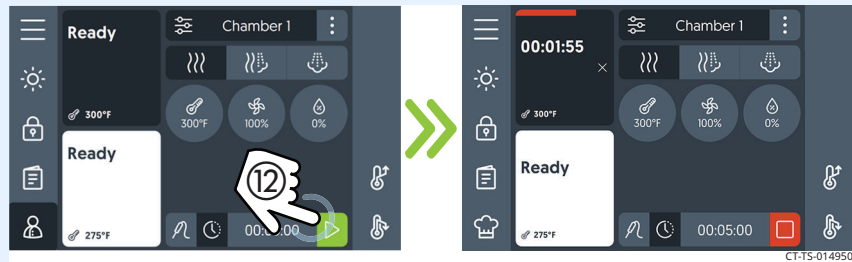

During the cooking process

Action	Result
Touch "X"...	to cancel the cooking process.

9. At the end of the cooking process, the oven sounds an alert, and the chamber light flashes.
10. **Open** the door and remove the hot food.

NOTE: Be sure to remove the cooked food after the cooking process is complete. The oven will revert back to the preheat temperature. If left inside the oven, the food will continue to cook.

Result

The food is now cooked.

How to Use the Dual Timers

Before you begin

Make sure:

- The oven is preheated.
- Your food is prepared and ready to cook.

Background

There may be times when you will want to use the same chamber to cook two pans of food at the same time, but at different intervals. The dual timer function allows you to do so.

Procedure

To cook using the dual timers, do the following.

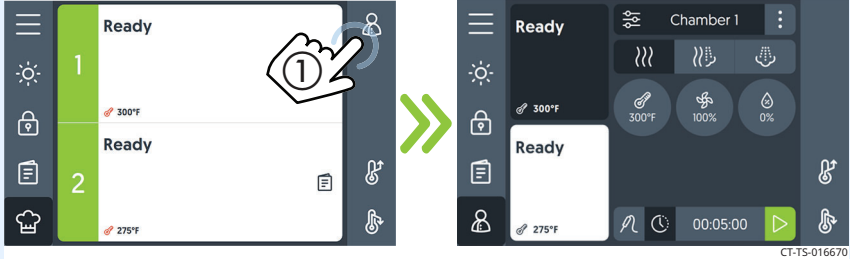
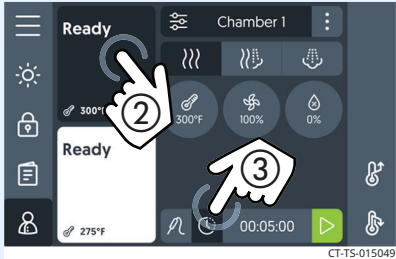
Step	Action
1.	From the manual cooking screen, touch the professional cook icon ①. The available chambers are displayed.
	
2.	Touch any available chamber ②. Touch the cook by time icon ③.
	

Continued on next page

Continued from previous page

3. **Touch** the chamber options icon (4). Then, **touch** the chamber multiple shelf icon (5).

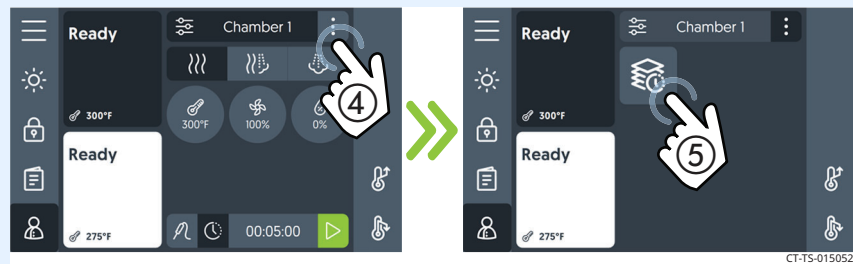

4. **Touch** the cooking time (6) for pan 1. **Enter** the cooking time using the key pad. **Touch** the check mark.

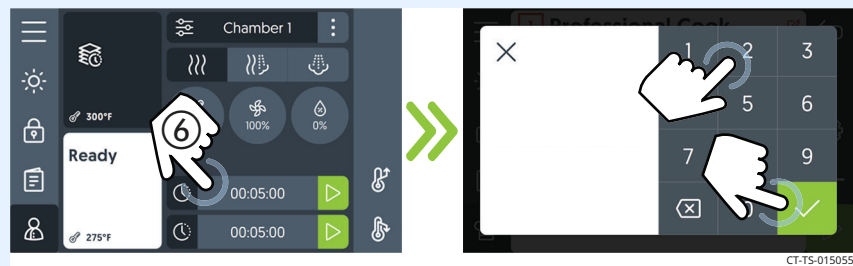

5. **Touch** the cooking time (7) for pan 2. **Enter** the cooking time using the key pad. **Touch** the check mark.

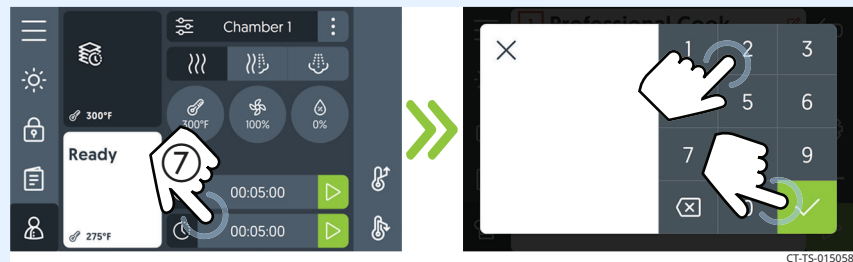

Continued on next page

Continued from previous page

6. **Touch** the cooking temperature ⑧. **Enter** the cooking temperature using the key pad. **Touch** the check mark.

Touch the humidity percentage ⑨. **Enter** the humidity percentage using the key pad. **Touch** the check mark.

Touch the fan speed ⑩. **Enter** the fan speed using the key pad. **Touch** the check mark.

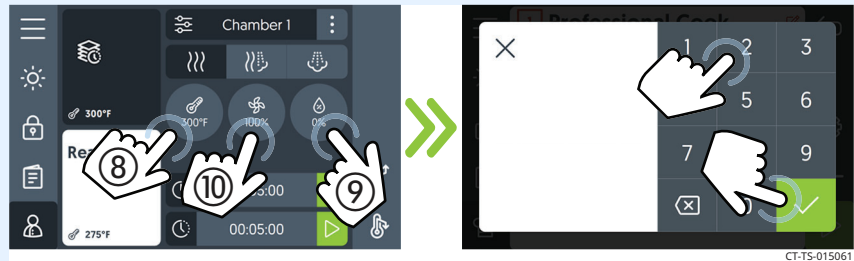

7. **Load** pan 1 into the appropriate chamber.

Touch the start icon ⑪.

The cooking stage timer starts to count down for pan 1.

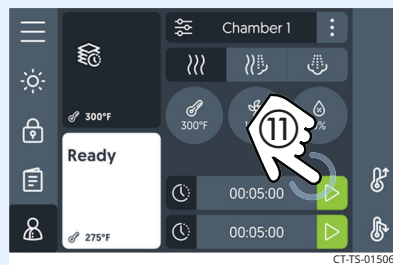

8. **Load** pan 2 into the appropriate chamber.

Touch the start icon ⑫.

The cooking stage timer starts to count down for pan 2.

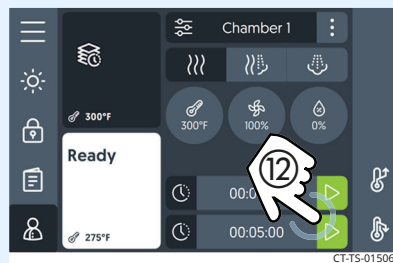

At the end of the cooking process, the oven sounds an alert, and the chamber light flashes.

Continued on next page

Continued from previous page

9. **Open** the door and remove the hot food.



NOTE: Be sure to remove the cooked food after the cooking process is complete. The oven will revert back to the preheat temperature. If left inside the oven, the food will continue to cook.

Result

The food is now cooked.

How to Lock and Unlock the Screen

Before you begin



The oven is turned on.

Background

The screen can be locked to prevent changes being made during the cooking process.

Procedure

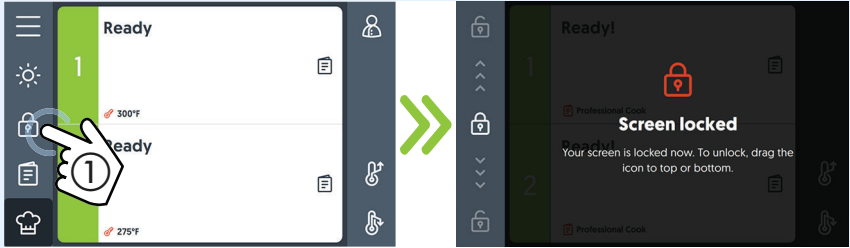
To lock and unlock the screen, do the following.

Step	Action
1.	<p>Touch the lock icon ①. The screen is now locked.</p>  <p>CT-TS-013948</p>
2.	<p>To unlock the screen, touch and hold the lock icon ① and drag it to the top or bottom of the screen.</p>  <p>CT-TS-013951</p>



Result

The screen is now locked or unlocked.

How to Cool Down the Oven

Procedure

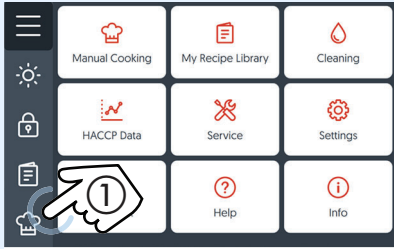
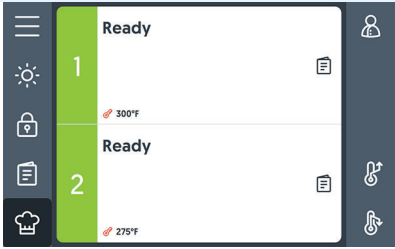
To cool down the oven, do the following.

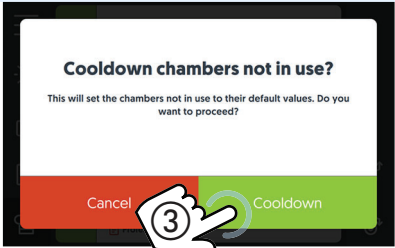
Step	Action
1.	<p>Touch the manual cook icon ①.</p>  
2.	<p>Touch the cool down icon ②. The cool down confirmation screen displays.</p> <p>Touch "Cooldown" ③. Open the door.</p> <p>NOTE: The oven activates the blowers for the cool down process. The oven deactivates the blowers when the cool down process is complete.</p>  

Cooling down progress bars

Progress bars indicate each chamber's progress towards reaching its cool down temperature.

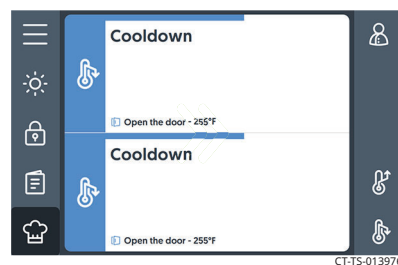

Result

The oven is now cooled down.

How to Create a Recipe



Background

Creating a recipe consists of:

- Setting the cooking stage(s) parameters (temperature, time, humidity percentage, and fan speed);
- setting an action step if desired such as adding an ingredient;
- naming the recipe;
- adding a description to the recipe;
- adding a photo to the recipe;
- and adding the recipe to a category.

Procedure

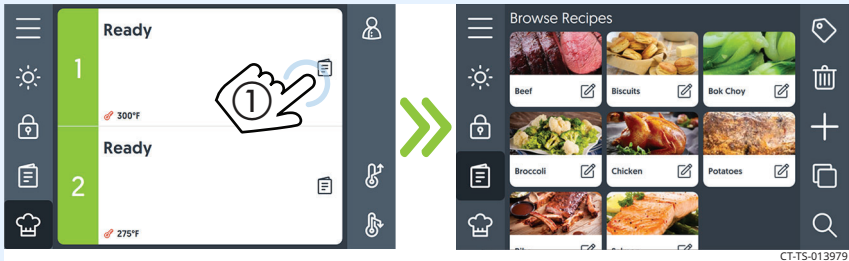
To create a recipe, do the following.

Step	Action
1.	<p>Touch the recipe book icon ①. The “Browse Recipes” screen displays.</p>  <p>The first screenshot shows a recipe book icon with a circled '1' and a hand cursor. A green arrow points to the second screenshot, which shows the 'Browse Recipes' screen with various recipe thumbnails like Beef, Biscuits, Bok Choy, Broccoli, Chicken, and Potatoes.</p> <p style="text-align: right; font-size: small;">CT-TS-013979</p>
2.	<p>Touch the plus icon ②. The step type screen displays.</p>  <p>The second screenshot shows the 'Browse Recipes' screen with a plus icon circled '2' and a hand cursor. A green arrow points to the third screenshot, which shows the 'Professional Cook' step type screen with options for Convection, Combi, Steam, and Action.</p> <p style="text-align: right; font-size: small;">CT-TS-014052</p>

Continued on next page

Continued from previous page

3. **Touch** a cooking mode or an action step icon ③ to choose the step type.

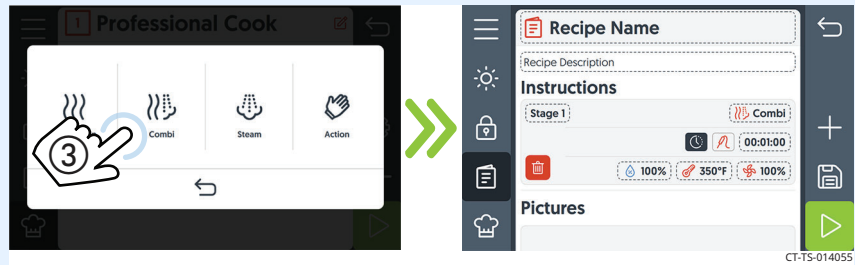

NOTE: Touching "Action" adds an action step to the recipe. An action adds manual tasks to be completed during the recipe such as loading the food or adding an ingredient.

4. **Touch** "Recipe Name" ④. The "Recipe name" screen displays.



5. **Enter** the recipe name. **Touch** the check mark ⑤ to return to the create recipe screen.

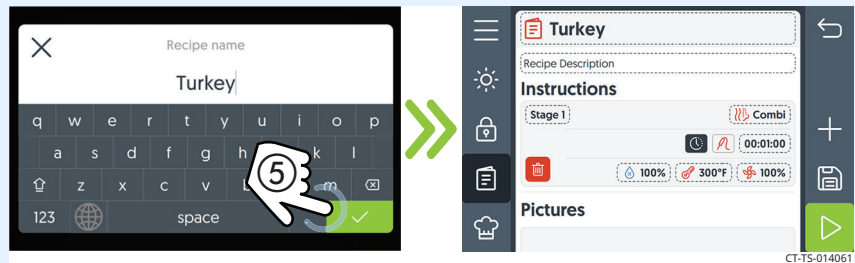

Continued on next page

Continued from previous page

6. **Touch** "Recipe Description" ⑥. The recipe description screen displays. **Enter** the recipe description. **Touch** the check mark to return to the create recipe screen.



7. **Touch** the cook by time icon or cook by probe icon ⑦. **Touch** the cooking time or probe set-point temperature ⑧. **Enter** the cooking time or probe temperature using the key pad. **Touch** the check mark.



8. **Touch** the humidity icon ⑨. **Enter** the humidity percentage using the key pad. **Touch** the check mark.

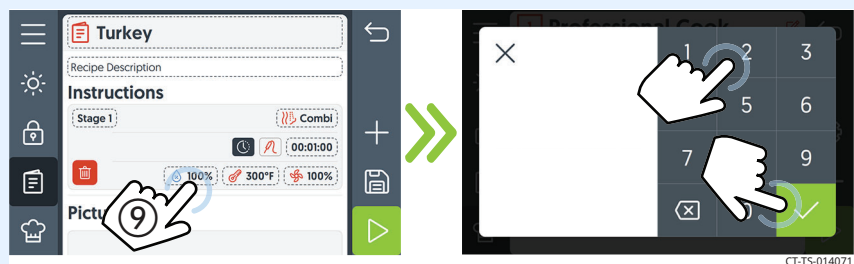

Continued on next page

Continued from previous page

9. **Touch** the chamber temperature set-point icon ⑩. **Enter** the chamber temperature set-point using the key pad. **Touch** the check mark.

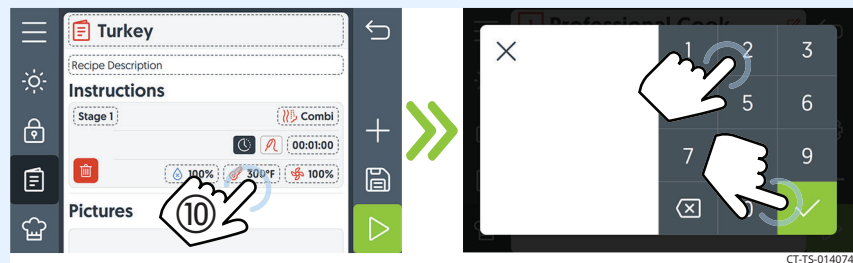

CT-TS-014074

10. **Touch** the fan speed icon ⑪ to set the fan speed. **Enter** the fan speed using the key pad. **Touch** the check mark.

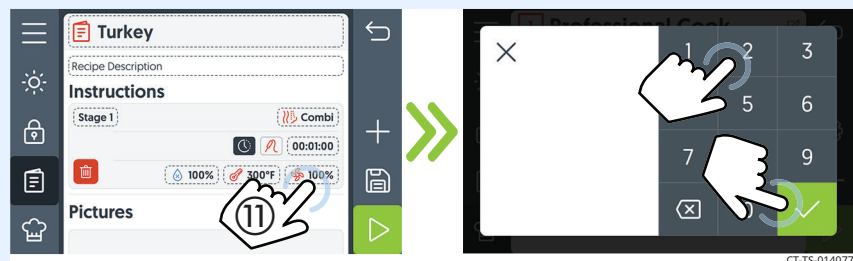

CT-TS-014077

11. **Touch** the plus icon ⑫ to add an additional stage or action. **Touch** the delete icon ⑬ to delete a stage or action.



CT-TS-014081

12. **Scroll** to "Pictures" to add a photo to the recipe.

13. **Scroll** to "Categories" to add the recipe to a category.

Continued on next page

Continued from previous page

14. **Touch** the save icon ⑭ when finished to save the recipe.

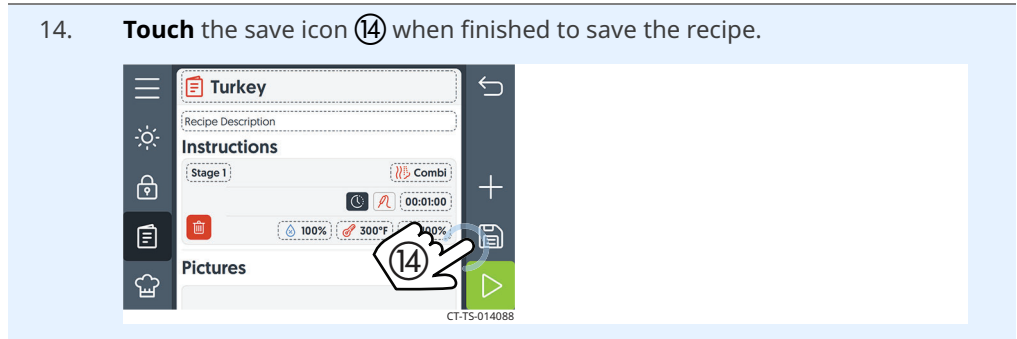

Result

A new recipe has been created.

How to Modify, Duplicate, or Delete a Recipe

Procedure

To modify, duplicate, or delete a recipe, do the following.

Step	Action
1.	Touch the recipe book icon ①. The “Browse Recipes” screen displays.
	
2.	To modify a recipe, touch the recipe edit icon ② of the desired recipe.
	

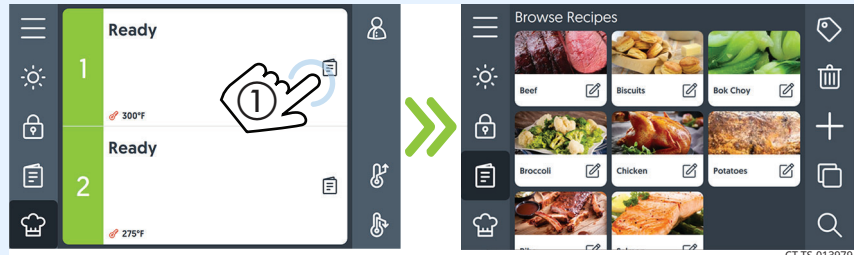

CT-TS-013979

Modifying

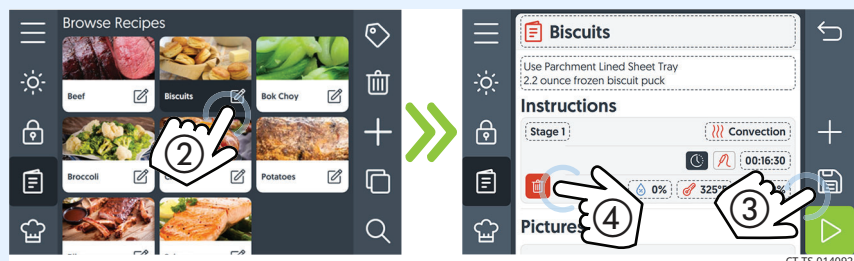

CT-TS-014092

The first stage of the recipe displays. There will be a screen for each stage. Scroll to the stage you want to modify.

- **Touch** the cook by time or cook by probe icon then modify the value using the key pad.
- **Touch** the humidity icon to modify the humidity percentage.
- **Touch** the chamber set-point icon to modify the chamber temperature.
- **Touch** the fan speed icon to modify the fan speed.

Touch the save icon ③ when finished.

Touch the trash icon ④ to delete the stage, if desired.

Continued on next page

Continued from previous page

Duplicating

- To duplicate a recipe, **touch** the duplicate recipe icon ④ of the desired recipe.

Touch the recipe to copy it. The recipe copy will display next to the recipe. Edit the copied recipe as desired.

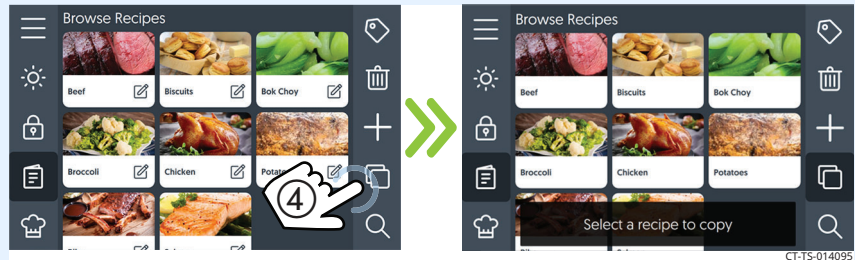

Deleting

- To delete a recipe, **touch** the delete icon ⑤.

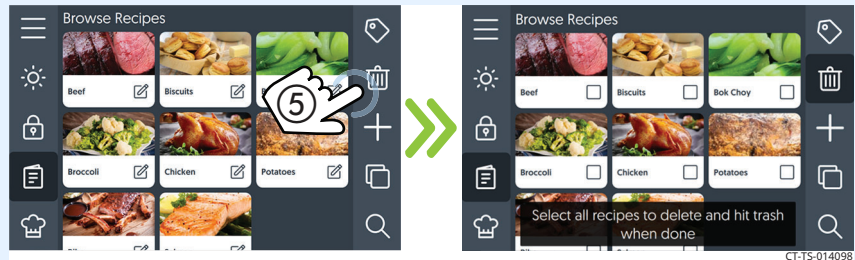

Select the recipe(s) that you want to delete. **Touch** the delete icon ⑤ again.

Touch "Continue" ⑥ to confirm that you want to delete the recipe(s).

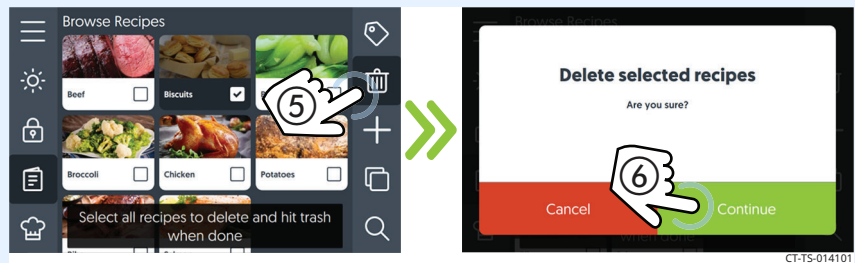

Result

The procedure is now complete.

How to Create a Category

Background

A category allows the user to label and group recipes together. When viewing a recipe, the user can add a recipe to a category by touching the check mark next to the desired category. The categories can be viewed at the bottom of an existing recipe screen.

A recipe can be assigned to multiple categories.

Procedure

To create a category, do the following.

Step	Action
1.	<p>Touch the recipe book icon ①. The “Browse Recipes” screen displays.</p>  <p>CT-TS-013979</p>
2.	<p>Touch the categories icon ②. The “Browse Categories” screen displays.</p>  <p>CT-TS-016752</p>
3.	<p>Touch the plus icon ③ to add a category. The “Create a Category” screen displays.</p>  <p>CT-TS-016755</p>

Continued on next page

Continued from previous page

4. **Enter** the category name. **Touch** the check mark ④. The category has been created.



CT-TS-014115

Duplicating

5. To duplicate a category, **touch** the duplicate category icon ⑤ of the desired category. **Touch** the category to copy it. The category copy will display next to the category.

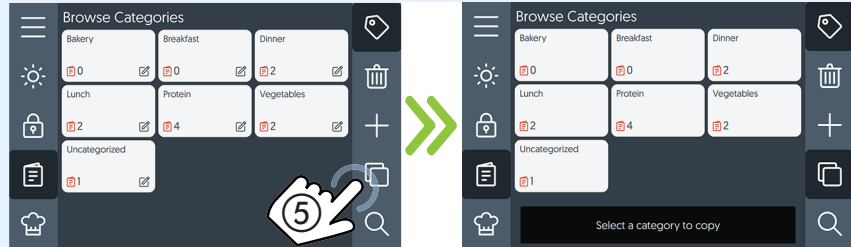

CT-TS-016758

Continued on next page

Continued from previous page

Deleting

6. To delete a category, **touch** the delete icon ⑥.

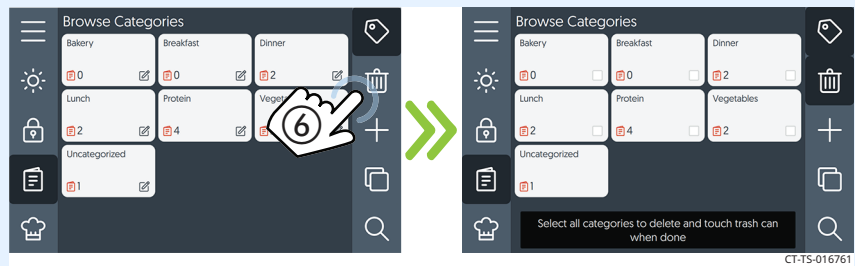

Select the category that you want to delete. **Touch** the delete icon ⑥ again.

Touch "Delete" ⑦ to confirm that you want to delete the category.



Result

The procedure is now complete.

How to Backup or Restore Settings with a USB Drive

Before you begin

You will need a USB drive.

Procedure

To backup or restore settings with a USB drive, do the following.

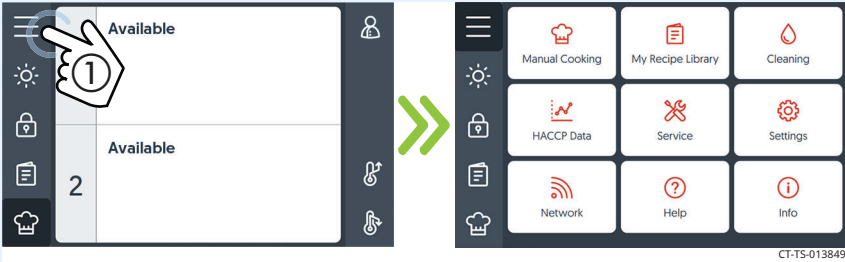
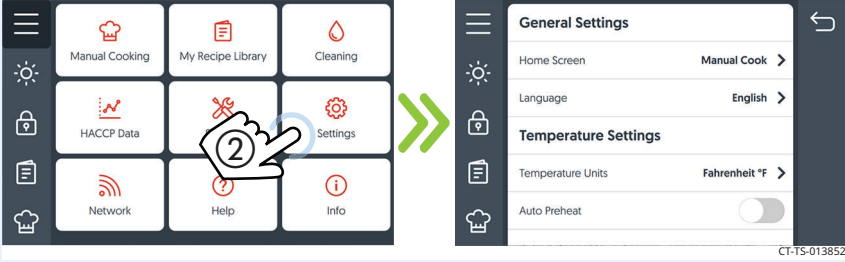
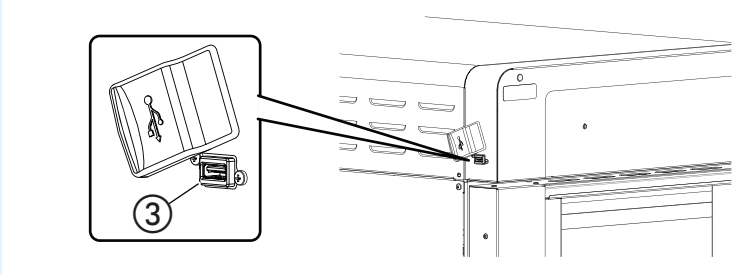
Step	Action
1.	<p>Touch the menu icon ①. The menu screen displays.</p>  <p style="text-align: right; font-size: small;">CT-TS-013849</p>
2.	<p>Touch the “Settings” icon ②. The “General Settings” screen displays.</p>  <p style="text-align: right; font-size: small;">CT-TS-013852</p>
3.	<p>Plug the USB drive ③ into the port.</p>  <p style="text-align: right; font-size: small;">VMC-TS-007852</p>

Continued on next page

Continued from previous page

4. **Scroll** to “System Backup & Update.”

Touch “Backup Settings to USB” or “Restore Settings from USB” ④. The USB screen displays.

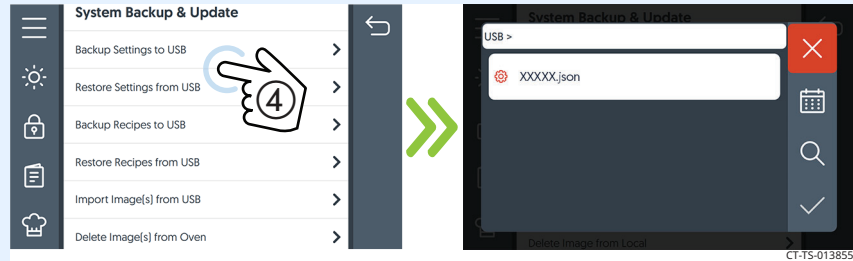

5. **Select** the settings file ⑤.

Touch the check mark ⑥.

NOTE: Subfolders can be set up on the USB drive from your computer. To import settings from a subfolder, touch a subfolder, select the settings file, then touch the check mark.



Loading the recipes

The oven downloads or restores the settings. When the process is complete, **touch** the check mark ⑦ to return to the general settings screen. **Remove** the USB drive.

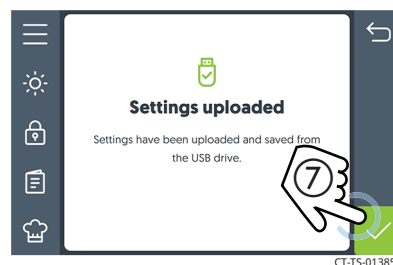

Result

The settings have now been saved to the USB drive or restored from the USB drive.

How to Backup Recipes to a USB Drive

Before you begin

You will need a USB drive.

Procedure

To backup recipes from the oven to a USB drive, do the following.

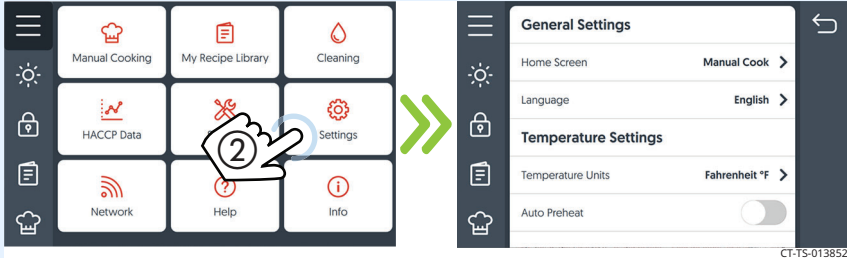
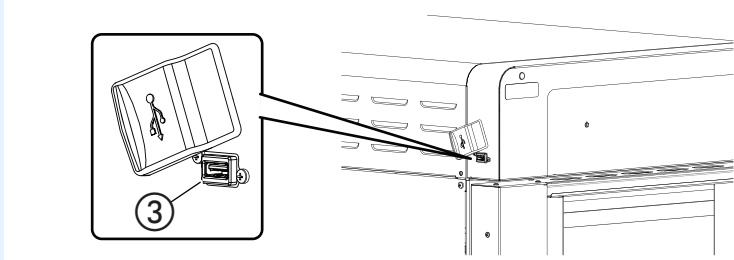
Step	Action
1.	<p>Touch the menu icon ①. The menu screen displays.</p>  <p style="text-align: right; font-size: small;">CT-TS-013849</p>
2.	<p>Touch the "Settings" icon ②. The "General Settings" screen displays.</p>  <p style="text-align: right; font-size: small;">CT-TS-013852</p>
3.	<p>Plug the USB drive ③ into the port.</p>  <p style="text-align: right; font-size: small;">VMC-TS-007852</p>

Continued on next page

Continued from previous page

4. **Scroll** to “System Backup & Update.”

Touch the “Backup Recipes to USB” ④ setting. The USB screen displays.

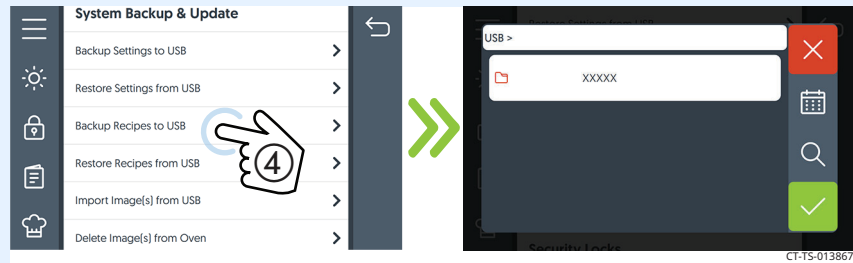

5. **Touch** the check mark ⑤ to save the recipes to the top level of the USB drive.

NOTE: Subfolders can be set up on the USB drive from your computer. To save a file to a subfolder, touch a subfolder then touch the check mark.



Loading the recipes

The oven downloads the recipes onto the USB drive. When the process is complete, the “Download successful” screen displays. **Touch** the check mark ⑥ to return to the general settings screen. **Remove** the USB drive.

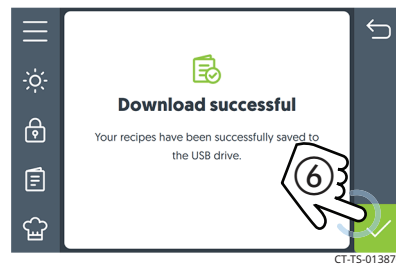

Result

The recipes are now saved to the USB drive.

How to Restore Recipes from a USB Drive

Before you begin

You will need a USB drive loaded with recipes.

Procedure

To restore recipes from the USB drive to the oven, do the following.

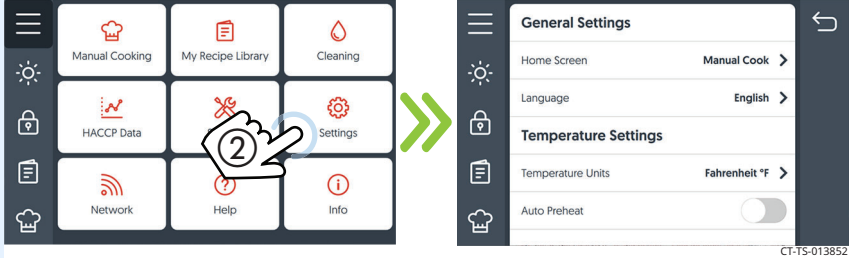
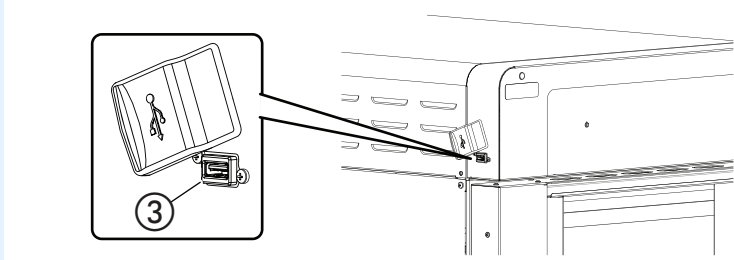
Step	Action
1.	<p>Touch the menu icon ①. The menu screen displays.</p>  <p style="text-align: right; font-size: small;">CT-TS-013849</p>
2.	<p>Touch the "Settings" icon ②. The "General Settings" screen displays.</p>  <p style="text-align: right; font-size: small;">CT-TS-013852</p>
3.	<p>Plug the USB drive ③ into the port.</p>  <p style="text-align: right; font-size: small;">VMC-TS-007852</p>

Continued on next page

Continued from previous page

4. **Scroll** to “System Backup & Update.”

Touch the “Restore Recipes from USB” ④ setting. The USB screen displays.

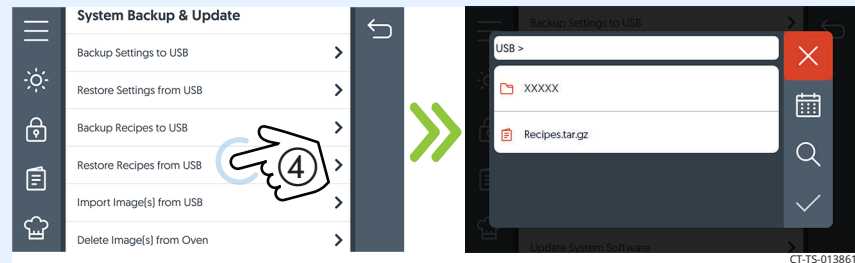

5. **Select** the recipe file ⑤. **Touch** the check mark ⑥ to load the recipes to the oven. **Select** “Overwrite” to overwrite existing recipe file or select “Keep” to keep existing recipes with the new recipe file.

NOTE: Subfolders can be set up on the USB drive from your computer. To load a file from a subfolder, touch a subfolder then touch the check mark.

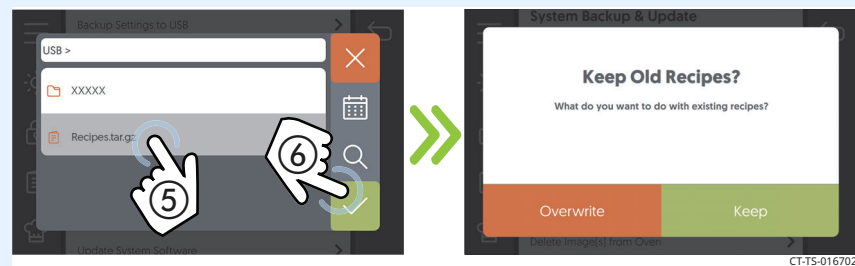

Loading the recipes

The oven loads the recipe file. When the process is complete, the “Recipes uploaded” screen displays. **Touch** the check mark ⑦ to return to the general settings screen. **Remove** the USB drive.



Result

The recipes are now restored.

How to Import Images from a USB Drive

Before you begin

You will need a USB drive loaded with the images.

Procedure

To import images from the USB drive to the oven, do the following.

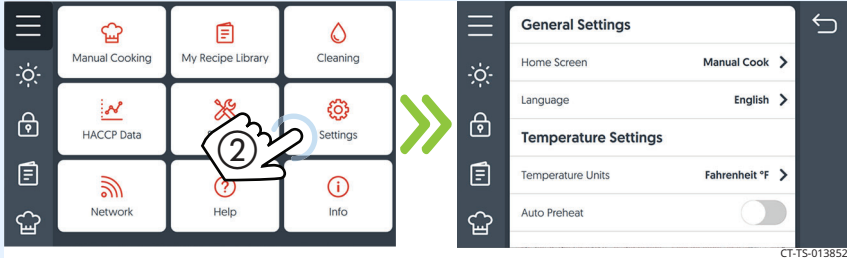
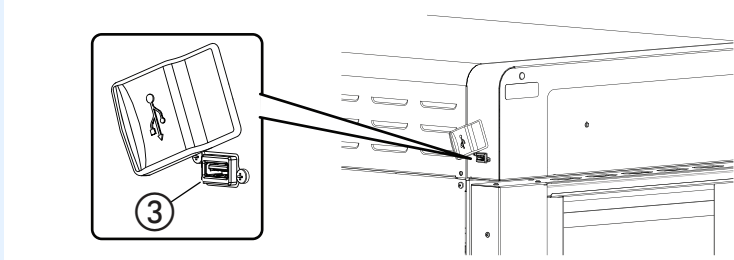
Step	Action
1.	<p>Touch the menu icon ①. The menu screen displays.</p>  <p style="text-align: right; font-size: small;">CT-TS-013849</p>
2.	<p>Touch the "Settings" icon ②. The "General Settings" screen displays.</p>  <p style="text-align: right; font-size: small;">CT-TS-013852</p>
3.	<p>Plug the USB drive ③ into the port.</p>  <p style="text-align: right; font-size: small;">VMC-TS-007852</p>

Continued on next page

Continued from previous page

4. **Scroll** to “System Backup & Update.”

Touch the “Import Image(s) from USB” ④ setting. The USB screen displays.

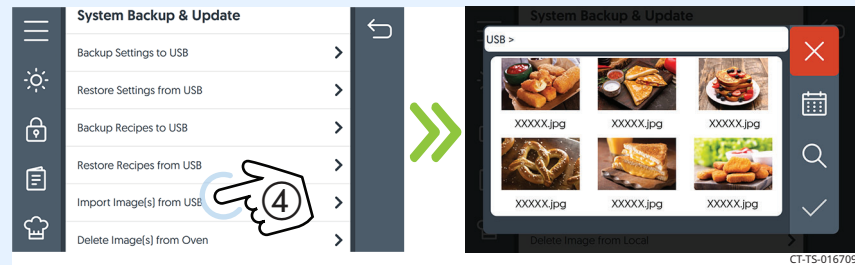

5. **Select** the images ⑤.

Touch the check mark ⑥.

NOTE: Subfolders can be set up on the USB drive from your computer. To import images from a subfolder, touch a subfolder, select the images, then touch the check mark.



Loading the images

The oven loads the selected images. When the process is complete, the “Images uploaded” screen displays. **Touch** the check mark ⑦ to return to the general settings screen. **Remove** the USB drive.

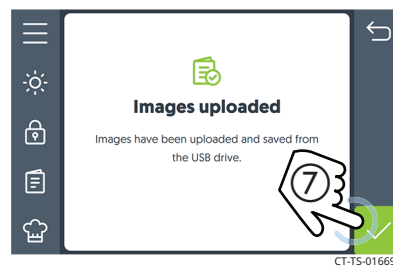

Result

The images are now imported.

How to Update Software with a USB Drive

Before you begin

Make sure:

- The oven is on and cool to the touch (room temperature).
- You will need a USB drive with the updated software. To download the most up to date oven software and register for email notifications when new software versions are released, please visit <https://www.alto-shaam.com/en/customer-support/software-downloads>.
- Do not remove the USB drive during the update process.

Procedure

To update the software, do the following.

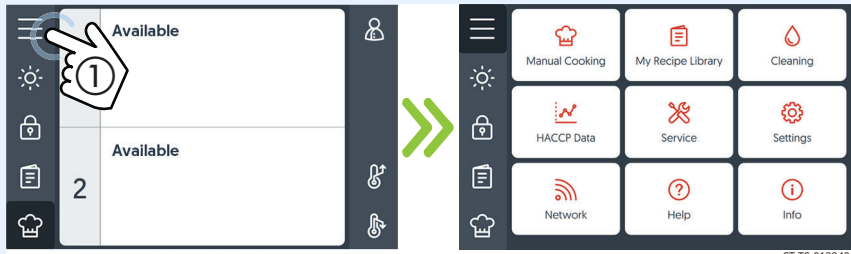
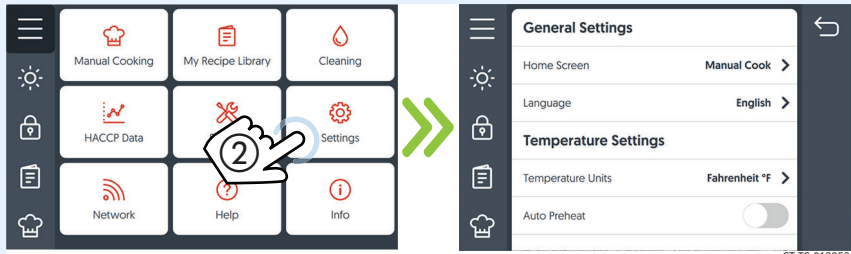
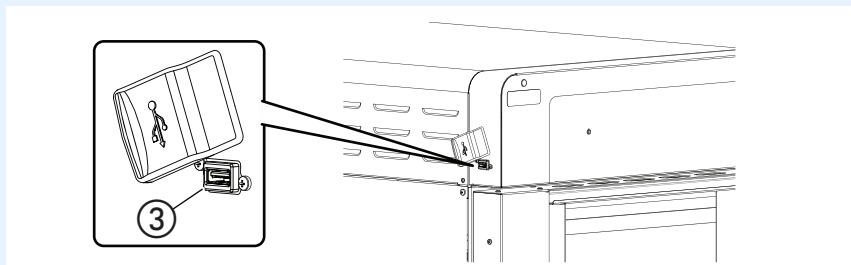
Step	Action
1.	<p>Touch the menu icon ①. The menu screen displays.</p>  <p style="text-align: right;"><small>CT-TS-013849</small></p>
2.	<p>Touch the “Settings” icon ②. The “General Settings” screen displays.</p>  <p style="text-align: right;"><small>CT-TS-013852</small></p>
3.	<p>Plug the USB drive ③ into the port.</p>  <p style="text-align: right;"><small>VMC-TS-007852</small></p>

Continued on next page

Continued from previous page

4. **Scroll to “System Backup & Update.”**

Touch the “Update System Software” ④ setting.

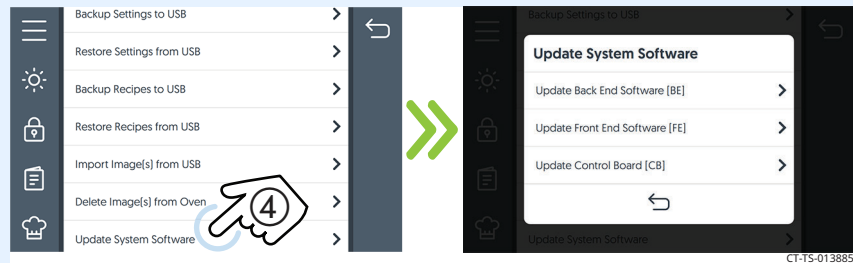

NOTICE Do not remove the USB drive during the update process.

5. **Touch “Update Back End Software (BE)” to update the supporting software between the control board (CB) and interface board (IB). Select the ASBE.bin file ⑤. Touch the check mark ⑥.** The oven loads the selected software. **Touch the check mark ⑦** when the update is complete to restart the oven.



6. **Repeat steps 1 through 4.**

Touch “Update Front End Software (FE)” to update the user interface software. Select the ASFE.bin file ⑧. Touch the check mark ⑨. The oven loads the selected software. **Touch the check mark ⑩** when the update is complete to restart the oven.

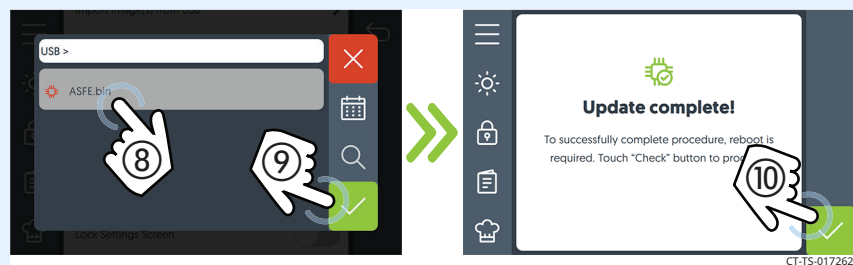

Continued on next page

Continued from previous page

7. **Repeat** steps 1 through 4.

Touch “Update Control Board (CB)” to update the control board. **Select** the file ⑪. **Touch** the check mark ⑫. The oven loads the selected software. The oven verifies the file and then updates the CB. **Touch** the check mark ⑬ when the update is complete to restart the oven.

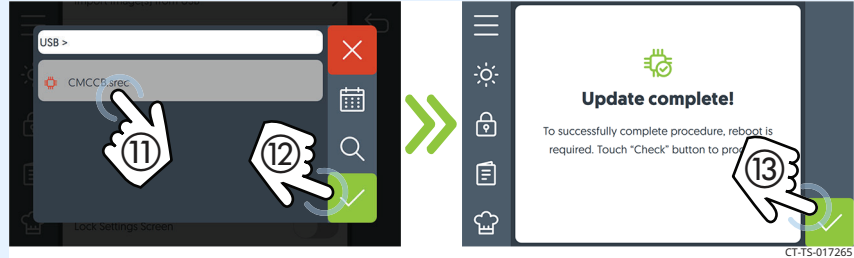

8. **Remove** the USB drive.

9. **Touch** the “Info” icon ⑭ to validate the software versions.

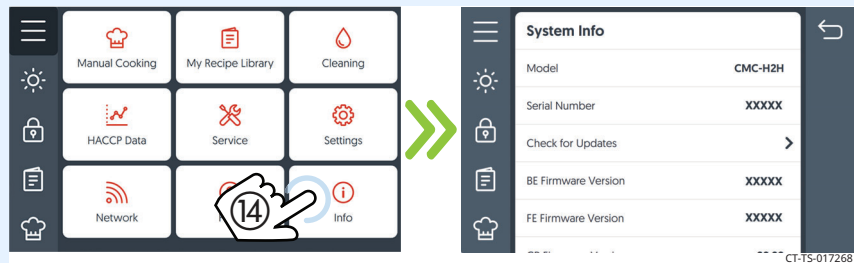

Result

The software has now been updated.

How to Check for and Download Available Software Updates

Background

- This procedure is to be done through the touchscreen on the Deluxe control, not through the ChefLinc™ oven management system.

The Check for Updates icon shows if there are waiting system software updates from ChefLinc™ or Alto-Shaam Technical Support. To download the most up to date oven software and register for email notifications when new software versions are released, visit <https://www.alto-shaam.com/en/customer-support/software-downloads>.

Procedure

To check for updates, do the following.

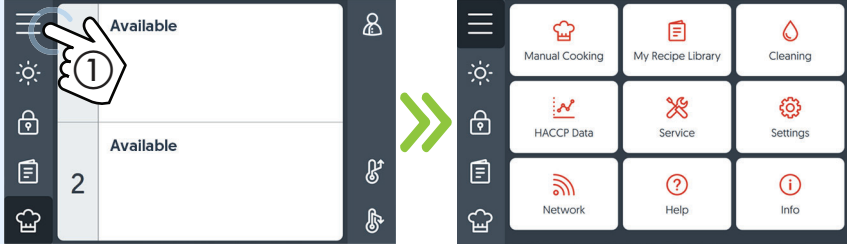
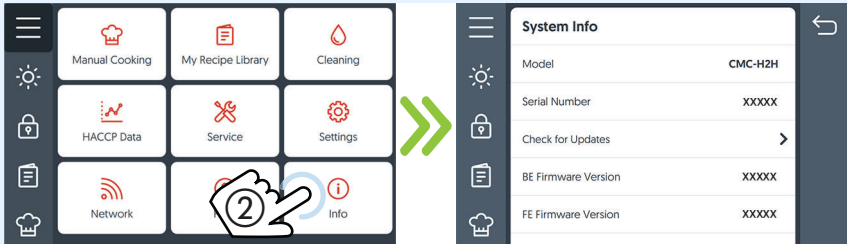
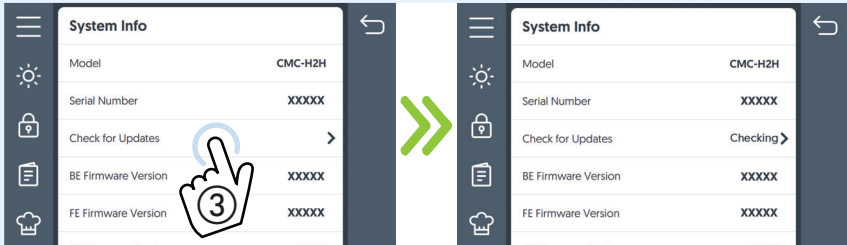
Step	Action
1.	<p>Touch the menu icon ①. The menu screen displays.</p>  <p style="text-align: right; font-size: small;">CT-TS-013849</p>
2.	<p>Touch the “Info” icon ②. The “System Info” screen displays.</p>  <p style="text-align: right; font-size: small;">CT-TS-013894</p>
3.	<p>Touch the “Check for Updates” icon ③. The display shows “Checking” and the oven downloads the latest software.</p>  <p style="text-align: right; font-size: small;">TH-TS-018357</p>

Continued on next page

Continued from previous page

- Once the oven is done downloading the system software, it will show "Remote Update" screen. You can choose to update later or restart now.

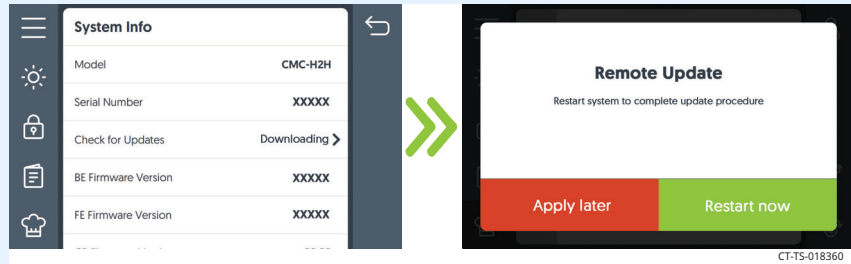

- Touch** the "Restart Now" icon ④. The display shows "Waiting for Reboot" until the oven restarts.



Result

The oven's software is updated.

How to Temporarily Change Languages

Background

This procedure is to allow a quick change from one language to another on the oven display screen. The language will revert back to the original language when oven power is cycled.

Procedure

To change language, do the following.

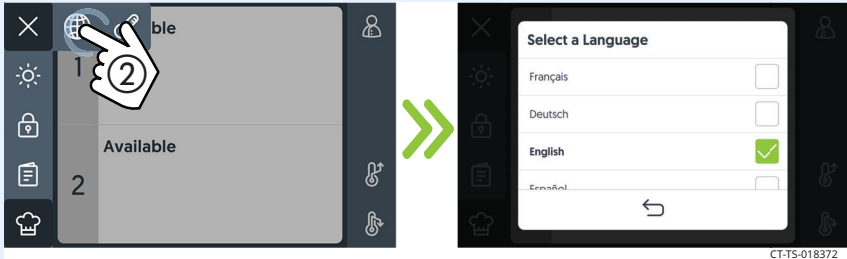
Step	Action
1.	<p>Touch and hold the menu icon ①. The language select icon displays.</p>  <p>CT-TS-018369</p>
2.	<p>Touch the language select icon ②. The “Select a Language” screen displays.</p> <p>Touch the language you wish to use. It will translate the oven operating functions into that language. Recipes language will not change.</p>  <p>CT-TS-018372</p>

Result

The oven’s language has been changed.

How to Temporarily Change Temperature Units

Background

This procedure is to allow a quick change between temperature units on the oven's display screen. The temperature unit will revert back to the original temperature units when oven power is cycled.

Procedure

To temporarily change the temperature units, do the following.

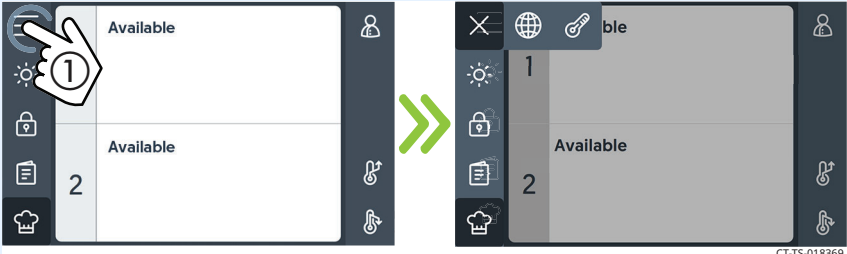
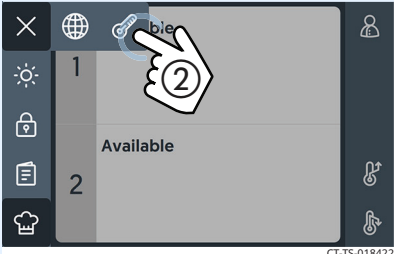
Step	Action
1.	<p>Touch and hold the menu icon ①. The temperature unit icon displays.</p>  <p style="text-align: right; font-size: small;">CT-TS-018369</p>
2.	<p>Touch the temperature unit icon ②.</p> <p>Repeat the procedure to toggle between temperature units.</p>  <p style="text-align: right; font-size: small;">CT-TS-018422</p>

Result

The oven's temperature units have now been changed.

How to Change the Home Screen

Procedure

To change the home screen, do the following.

Step	Action
1.	<p>Touch the menu icon ①. The menu screen displays.</p>  <p>CT-TS-013849</p>
2.	<p>Touch the “Settings” icon ②. The “General Settings” screen displays.</p>  <p>CT-TS-013852</p>
3.	<p>Touch the “Home Screen” setting ③. The select home screen menu displays.</p>  <p>CT-TS-013873</p>

Continued on next page

Continued from previous page

4. **Select** your desired home screen from the list.
Touch the check mark ④ to save the home screen setting.

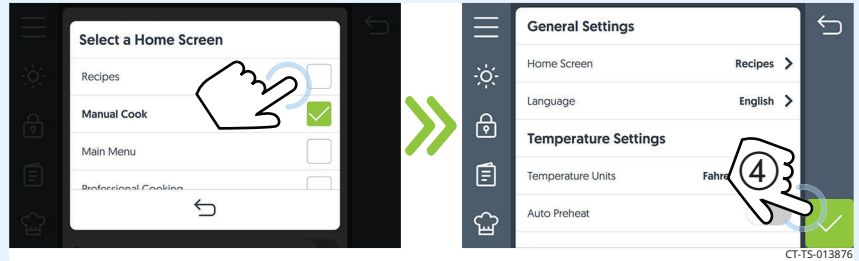

5. **Restart** the oven to reboot the home screen.

Result

The home screen has now been changed.

How to Change the Temperature Scale

Procedure

To change the temperature scale from °F to °C and vice versa, do the following.

Step	Action
1.	<p>Touch the menu icon ①. The menu screen displays.</p>  <p>CT-TS-013849</p>
2.	<p>Touch the “Settings” icon ②. The “General Settings” screen displays.</p>  <p>CT-TS-013852</p>
3.	<p>Touch the “Temperature Units” setting ③. The select temperature units screen displays.</p>  <p>CT-TS-013879</p>

Continued on next page

Continued from previous page

4. **Select** your desired temperature scale.

Touch the check mark ④ to save the temperature scale setting.

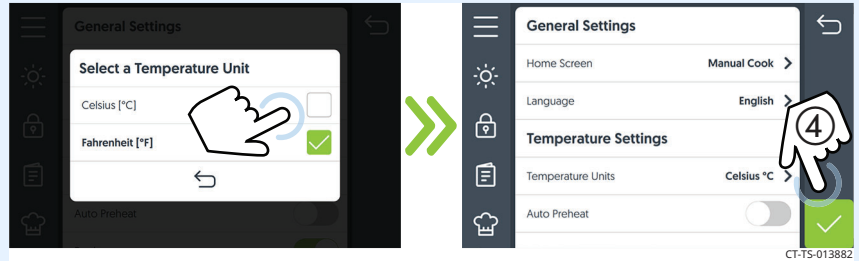

Result

The temperature scale has now been changed.

How to Change the Cooking Complete Notification Sound

Background

When a cooking process is complete, the oven sounds an alert. This alert sound can be changed using the settings menu.

Procedure

To change the cooking complete notification sound, do the following.

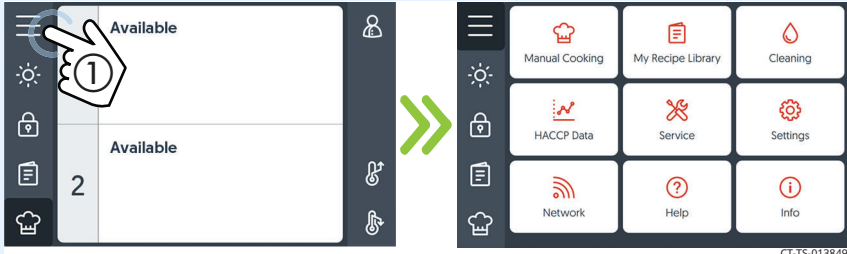
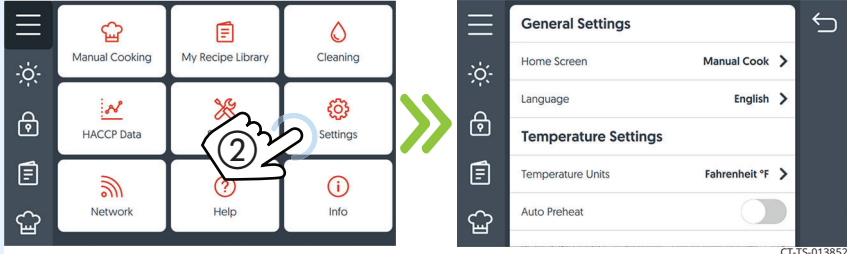
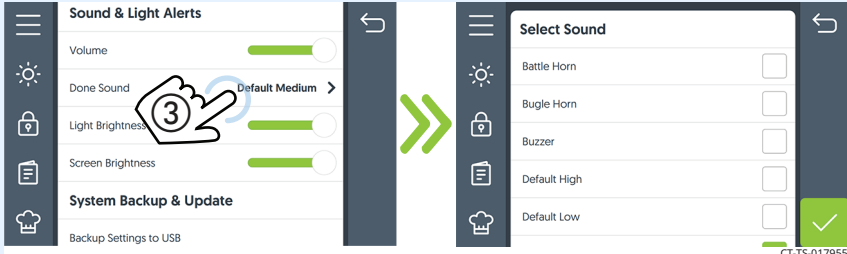
Step	Action
1.	<p>Touch the menu icon ①. The menu screen displays.</p>  <p>CT-TS-013849</p>
2.	<p>Touch the “Settings” icon ②. The “General Settings” screen displays.</p>  <p>CT-TS-013852</p>
3.	<p>Scroll to “Sound & Light Alerts.”</p> <p>Touch the “Done Sound” ③ setting. The “Select Sound” screen displays.</p>  <p>CT-TS-017955</p>

Continued on next page

Continued from previous page

4. **Select** your desired notification sound from the list. **Touch** the check mark ④.

NOTE: Touching a different sound option will play a sample sound.

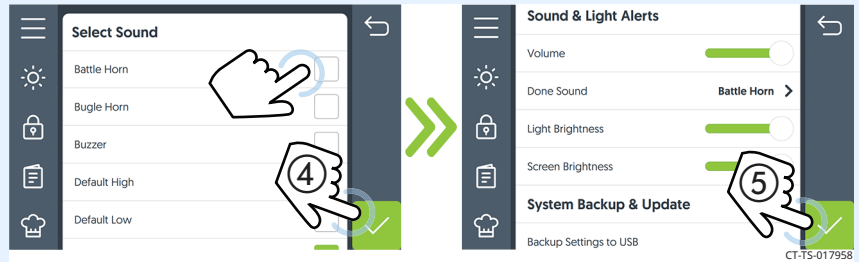

5. **Touch** the check mark ⑤ to save the setting.

Result

The cooking complete notification sound has now been changed.

How to Enable/Disable Automatic Preheat

Background

Enabling the automatic preheat function preheats the oven upon start up to the set preheat temperature. Make sure to set your preheat temperatures. See topic *How to Preheat the Oven*.

Procedure

To enable/disable automatic preheat, do the following.

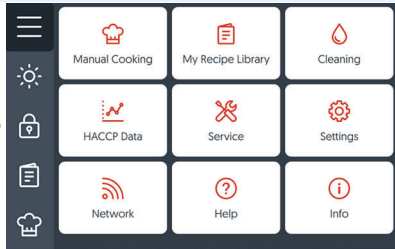
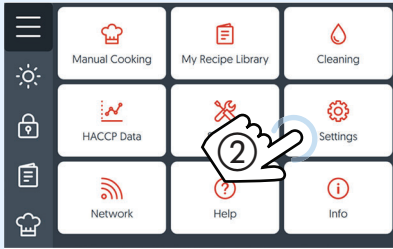
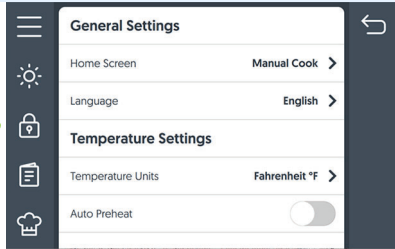
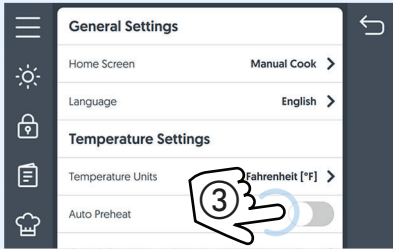
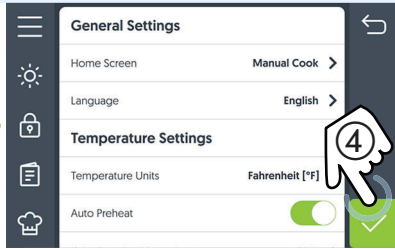
Step	Action
1.	<p>Touch the menu icon ①. The menu screen displays.</p>   <p style="text-align: right; font-size: small;">CT-TS-013849</p>
2.	<p>Touch the “Settings” icon ②. The “General Settings” screen displays.</p>   <p style="text-align: right; font-size: small;">CT-TS-013852</p>
3.	<p>Touch the “Auto Preheat” button ③. Touch the check mark ④. The automatic preheat function is now enabled.</p> <p>Repeat the process to disable the automatic preheat function.</p>   <p style="text-align: right; font-size: small;">CT-TS-013933</p>

Result

The automatic preheat function is now enabled/disabled.

How to Enable/Disable “Press and Hold” Cook Cancel function

Background

When the Press and Hold Cook Cancel function is enabled, users must press and hold the X on the cooking screen to cancel a cook. This is to prevent any accidental touches from canceling a cook.

Procedure

To enable/disable Press and Hold Cook Cancel function, do the following.

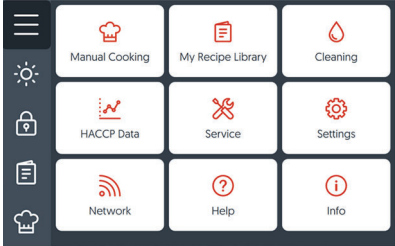
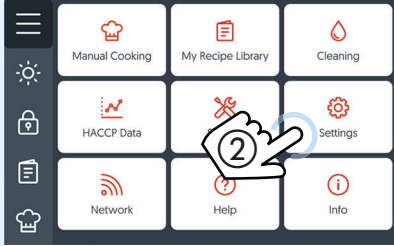
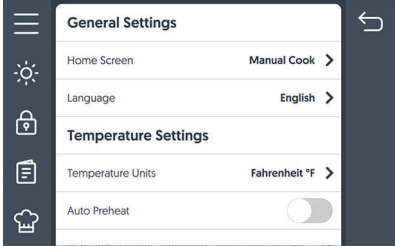
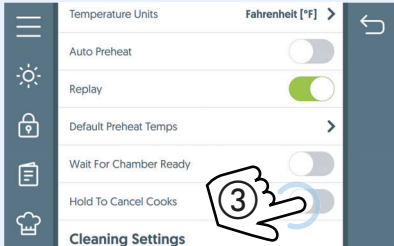
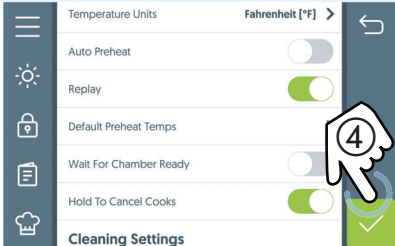
Step	Action
1.	<p>Touch the menu icon ①. The menu screen displays.</p>   <p>CT-TS-013849</p>
2.	<p>Touch the “Settings” icon ②. The “General Settings” screen displays.</p>   <p>CT-TS-013852</p>
3.	<p>Scroll to the “Temperature” setting. Touch the “Hold to Cancel Cooks” button ③. Touch the check mark ④. The Press and Hold Cook Cancel function is now enabled.</p> <p>Repeat the process to disable the Press and Hold Cook Cancel function.</p>   <p>VMC-TS-018478</p>

Result

The Press and Hold Cook Cancel function is now enabled/disabled.

How to Enable and Use the Replay Function

Background

When a cooking process is complete, the replay function repeats the same cooking process when you touch the replay icon. The replay function can be used for a programmed recipe or manual cook.

Procedure

To enable the replay function, do the following.

Step	Action
------	--------

1. **Touch** the menu icon ①. The menu screen displays.



2. **Touch** the “Settings” icon ②. The “General Settings” screen displays.

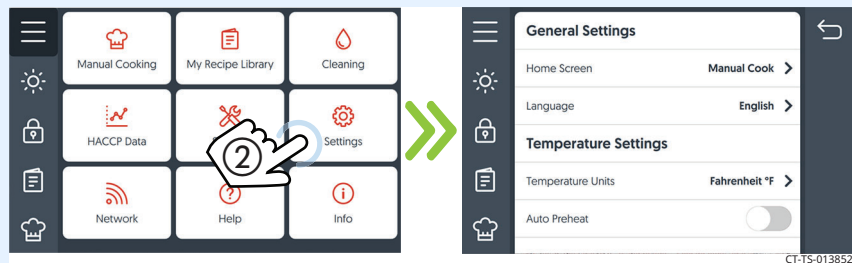

3. **Scroll** to the “Temperature Settings.”

Touch the Replay button ③. **Touch** the check mark ④. The replay function is now enabled.

Repeat the process to disable the replay function.

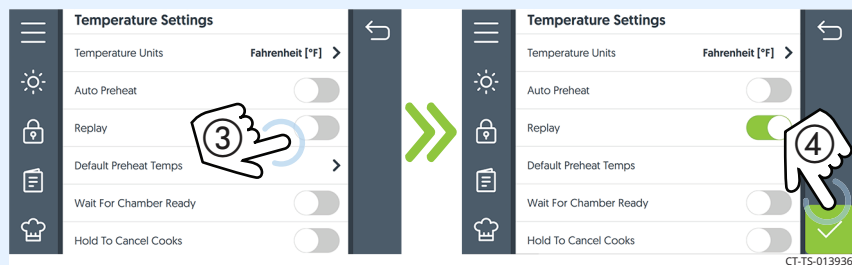

Continued on next page

Continued from previous page

Using the replay function (if enabled)

4. If the replay function is enabled, when the cooking process is complete, **touch** the replay icon ⑤ to repeat the previous cooking process.

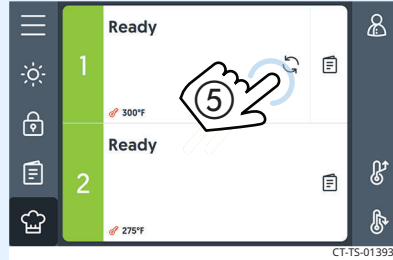

Result

The procedure is now complete.

How to Lock Recipe Editing, Manual Cooking, or the Settings Screen

Procedure

To lock recipe editing, manual cooking, or the settings screen, do the following.

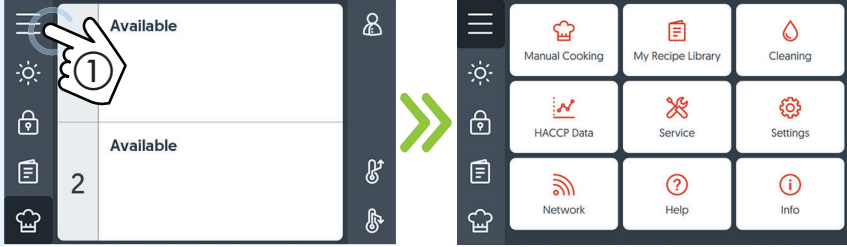
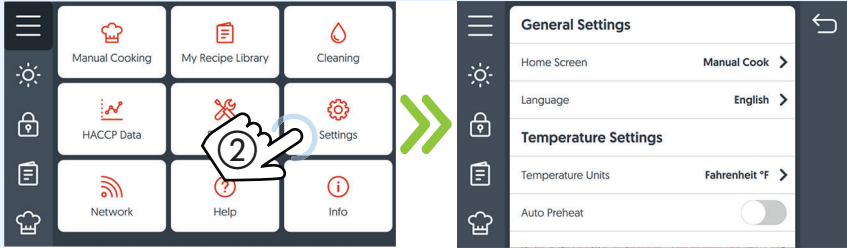
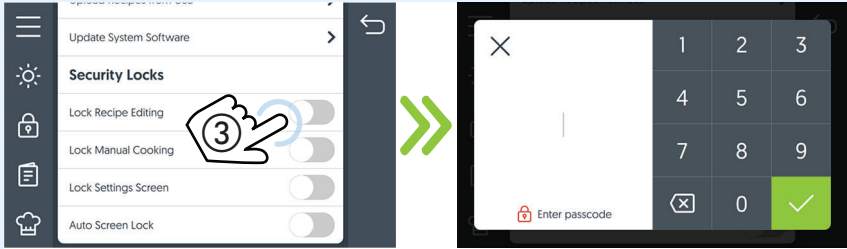
Step	Action
1.	<p>Touch the menu icon ①. The menu screen displays.</p>  <p>CT-TS-013849</p>
2.	<p>Touch the "Settings" icon ②. The "General Settings" screen displays.</p>  <p>CT-TS-013852</p>
3.	<p>Scroll to the "Security Locks."</p> <p>Touch the Lock Recipe Editing button ③. The "Enter passcode" screen displays.</p>  <p>CT-TS-013942</p>

Continued on next page

Continued from previous page

4. **Create** a passcode ④ using the keypad. **Touch** the check mark ⑤).
Touch the check mark ⑥ to lock recipe editing.

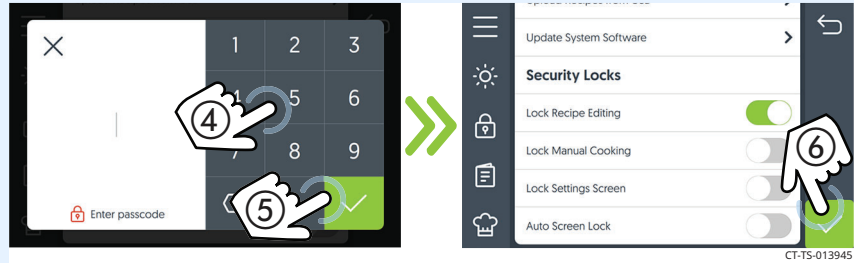

5. **Repeat** the process to lock manual cooking or lock the settings screen.

Result

The lock recipe editing, manual cooking, or the settings screen are now locked.

How to View Oven Information

Background

This procedure is to be done through the touchscreen on the Deluxe control, not through the ChefLinc™ oven management system.

The oven information screen shows the oven model, serial number, and system software.

Procedure

To view oven information, do the following.

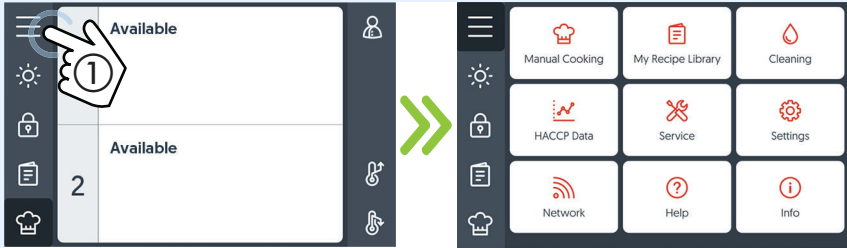
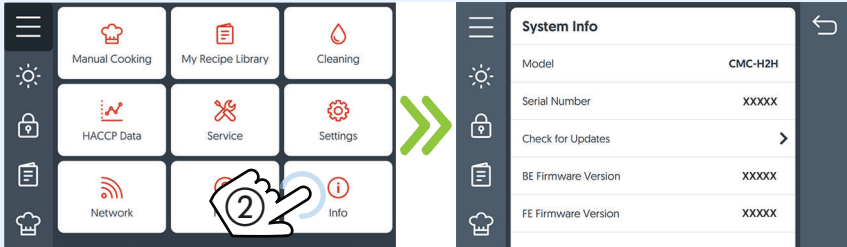
Step	Action
1.	<p>Touch the menu icon ①. The menu screen displays.</p> 
2.	<p>Touch the “Info” icon ②. The “System Info” screen displays.</p> <p>Scroll to view the oven model, serial number, and system software.</p> 

Result

The oven's information has been viewed.

How to Download HACCP Data

Before you begin

You will need a USB drive.

Background

HACCP data provides automated record keeping, set-point validation, recipes used, dates and times. The data is stored until the information is downloaded. Once downloaded, the information is removed from the oven's memory. Best practice would be to download the information every 30 days to a USB drive. The file format is plain text file (.csv). The file can be viewed in Microsoft® Excel.

Procedure

To download HACCP data, do the following.

Step	Action
1.	<p>Touch the menu icon ①. The menu screen displays.</p>  <p style="text-align: right; font-size: small;">CT-TS-013849</p>
2.	<p>Touch the "HACCP Data" icon ②. The "HACCP Data" screen displays.</p>  <p style="text-align: right; font-size: small;">CT-TS-013897</p>

Continued on next page

Continued from previous page

3. **Plug** the USB drive ③ into the port.

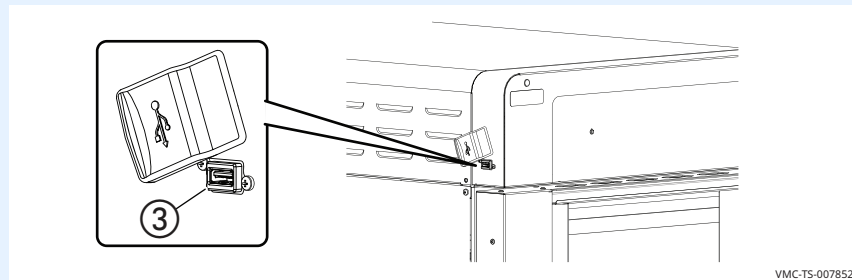

4. **Touch** the download icon ④.



Loading the data

The oven downloads the data onto the USB drive. When the process is complete, the “Download Successful” screen displays. **Touch** the check mark ⑤ to return to the menu screen. **Remove** the USB drive.

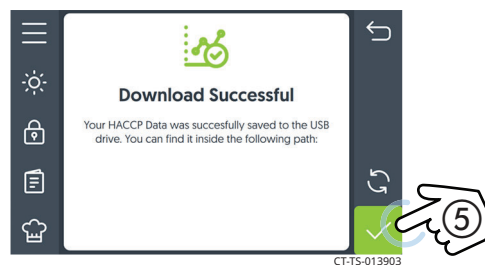

Result

The HACCP data has now been downloaded.

How to Calibrate the Temperature Probe

Before you begin

Make sure:

- The oven is on, but not in cooking mode.
- You have a thermometer.
- You have a container filled with ice and water.

Procedure

To calibrate the probe, do the following.

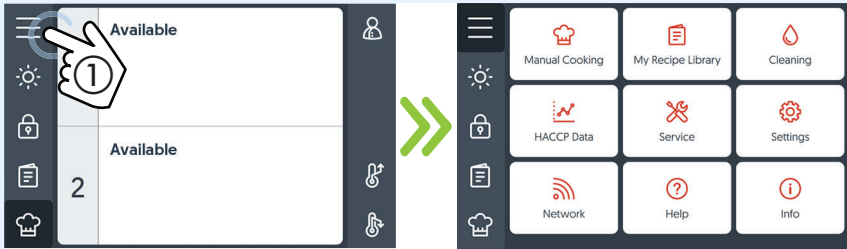
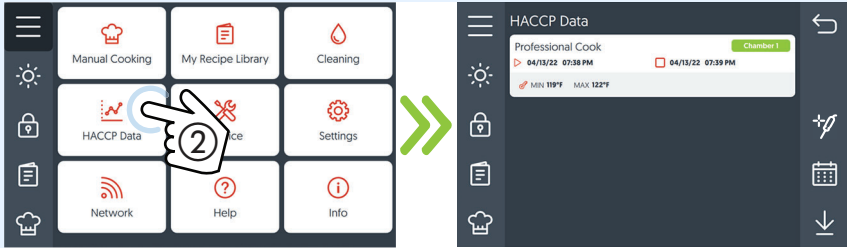
Step	Action
1.	Insert the probe and the thermometer in a container of ice water and allow the temperature to settle to 32°F (0°C).
2.	Touch the menu icon ①. The menu screen displays.
	
3.	Touch the “HACCP Data” icon ②. The “HACCP Data” screen displays.
	

Continued on next page

Continued from previous page

4. **Touch** the calibrate probes icon ③.

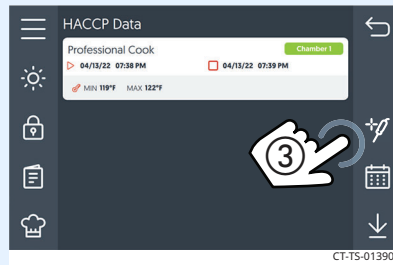

5. **Compare** the probe temperature reading against 32°F (0°C).
Touch the "+" or "-" symbols ④ until the temperature displayed is 32°F (0°C).
Touch the check mark ⑤.

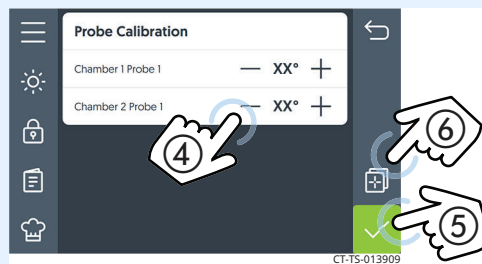

NOTE: Touch the probe calibration data icon ⑥ to view the probe calibration history.

6. **Remove** the probe from the ice water.
7. If the oven has multiple probes, repeat this procedure until all probes are calibrated.

Result

The probe is now calibrated.

This page is intentionally left blank.

Maintenance Schedule

Requirements

- See topic *How to Clean the Oven*.
- Make sure the oven is cooled down and off—inside of chamber 140°F (60°C) or less.

Daily

For daily maintenance, do the following.

- **Remove** any spills with disposable paper wipes or a damp cloth.
- **Wipe** the outside of the oven with a damp cloth.
- **Wipe** the oven gaskets with soap and water.
- **Inspect** the oven gaskets for damage.
- **Wipe** the front door glass.
- **Check** the screen for cracking or peeling. Contact Technical Service if needed.

Weekly

For weekly maintenance, do the following.

- **Clean** the entire oven. **Make sure** to use a non-abrasive nylon scrub pad.
- Do not spray the cleaner directly into the fan openings located in the rear of the oven.

Monthly

For monthly maintenance, do the following.

- **Inspect** and clean the air filters.
- **Clean** out the drip tray line.
- **Check** the supplied water filtration and change as needed.
- **Check** for software updates.
- **Check** lighting.
- **De-scale** as needed.

Yearly

For yearly maintenance, do the following.



NOTE: Must be performed by a qualified professional.

- **Inspect** and test the humidity control.
- **Inspect** and test the catalytic converter element.
- **Inspect** the catalytic converter.
- **Inspect** the air intake. **Check** the length of the tubing for debris clean out or replace as needed.

Continued on next page

Continued from previous page

- **Inspect** all drain hoses and clamps.
- **Inspect** all steam water injection lines and clamps for leaks or potential issues.
- **Inspect** wiring to heating elements. Re-tighten or secure as needed. Record the amp draw.
- **Inspect** wiring to the steam element. Re-tighten or secure as needed. Record the amp draw.
- **Inspect** the cleaning system pump and hoses for leaks and proper operation.
- For ovens shipped to New Zealand or Australia, **inspect** the back flow preventer check valve per AS/NZ3500.1 and AS/NZ3500.2

-
- **Check** operation of all electrical cooling fans.
 - **Check** all electrical connections are properly connected and secure to the boards.
 - **Check** door hinges and handles. Tighten, secure, or adjust as needed.
 - **Check** door gaskets for damage and seal.

-
- **Test** steam injection solenoid.
 - **Test** condensate solenoid.
 - **Run** each chamber in convection mode and test operation.
 - **Run** each chamber in steam mode and test operation.

How to Clean the Oven

Precautions



WARNING: Burn hazard.

Wear protective gloves, protective clothing, eye protection, and face protection when handling oven cleaner. Do not open the oven door during the cleaning cycle.

NOTICE

Using improper cleaning procedures will damage the catalyst and void the warranty.

Use only Alto-Shaam cleaner CE-49338 and oven decarbonizer + degreaser spray CE-48623 when cleaning. The use of any other cleaning chemical may damage the catalyst and void the warranty.

Do not use steel pads, wire brushes, or scrapers when cleaning.

Background

The oven has seven different cleaning modes — six for cleaning the oven, identified with blue icons, and one for descaling the catalyst, identified with a green icon. The spray cleanings are not visible by default. You can make them visible by adjusting the visible cleanings setting, see topic *How to Set Up Visible Cleanings*.

- The rinse cycle is a mid-day rinse to reduce grease and requires no cleaner packets.
- The spray clean cycle is for daily use when cooking heavy proteins and requires no cleaner packets.
- The light clean cycle is for light debris and requires one cleaner packet.
- The medium clean cycle is for heavy debris (10 full loads of chicken) in one chamber and requires three cleaner packets.
- The heavy clean cycle is for heavy debris (10 full loads of chicken) in all chambers and requires six cleaner packets.
- The descale catalyst cleaning keeps the oven's catalyst properly maintained. A reminder screen displays after 18 hours of cumulative cleaning (example: after four heavy cleaning cycles). See topic: "How to Descale the Catalyst" to descale the catalyst.



Continued on next page

Continued from previous page

Cleaning the oven

To clean the oven, do the following.

Step	Action
1.	Clean the door glass with Windex® or equivalent glass cleaner.
2.	Clean out any debris from behind the divider gaskets. 
<p>NOTE: Do not remove the jet plates during a cleaning cycle.</p>	
3.	Clean the door gasket with soap and water.
4.	Close the door. Spray the exterior of the oven with stainless steel polish. Wipe the exterior of the oven with a non-abrasive scrub pad. Follow the safety instructions on the bottle of stainless steel polish.
<p>NOTICE Use only non-caustic cleaners. Do not spray directly into the fan openings on the rear of the oven. Do not use cleaners that contain sodium hydroxide (lye) or phosphorus.</p>	
5.	Touch the menu icon ①. The menu screen displays. 

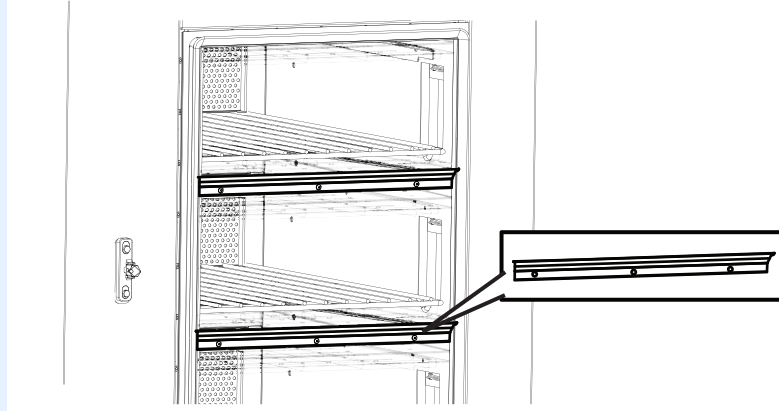

CT-TS-016588



NOTICE

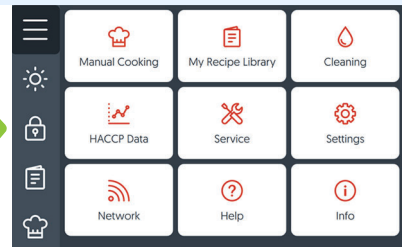

CT-TS-013849

Continued on next page

Continued from previous page

6. **Touch** the “Cleaning” icon ②. The “Cleaning” screen displays.

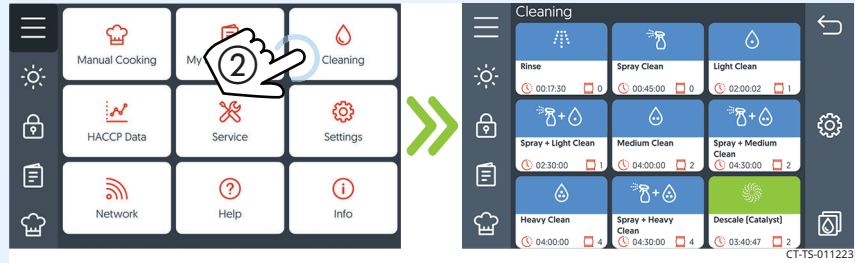

7. To “Spray Clean” or “Spray + Heavy Clean” ③, continue.
To “Rinse”, “Light Clean” or “Medium Clean” go to step 9.

Spray cleaning

8. **Shake** the oven decarbonizer + degreaser bottle gently four times before using. **Apply** 10-12 pumps per chamber, then **touch** “Continue”.
Distribute the contents of the cleaner packets onto the jet plates equally between the chambers. Make sure to place the cleaner packet(s) in the back right corner of the chamber.

Touch the start icon ④.



NOTE: Both programs start with a built-in 30-minute rest for the oven decarbonizer + degreaser to loosen carbon/grease buildup. The cleaning cycle then runs.

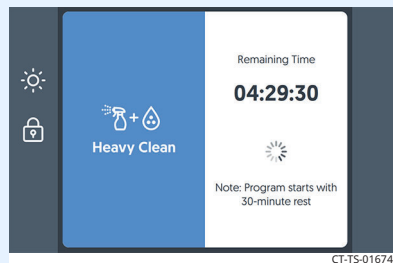

Proceed to step 10.

Continued on next page

Continued from previous page

Non-spray cleaning

9. **Select** "Rinse", "Light Clean" ⑤ or "Medium Clean".

Distribute the contents of the cleaner packets onto the jet plates equally between the chambers. No packets are required for "Rinse" clean. Make sure to place the cleaner packet(s) in the back right corner of the chamber.

Touch the start icon ⑥.

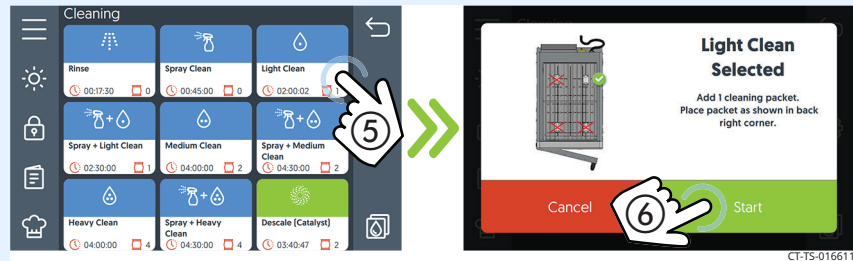

The oven heats to the required temperature for the cleaning cycle, then the cleaning cycle starts.

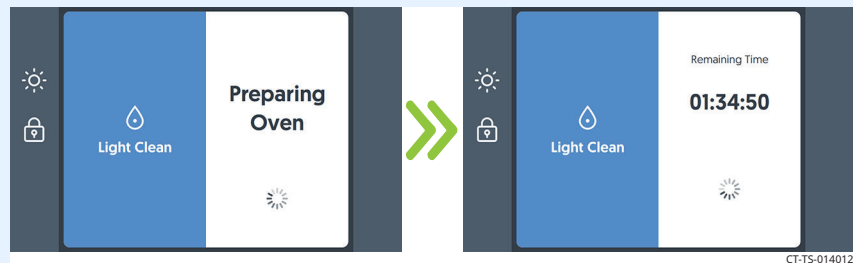

10. **Touch** "Ok" ⑦ when the cleaning cycle is complete.



WARNING: Burn hazard.

Open the door carefully when the cleaning cycle is complete. Escaping hot vapors or steam can cause injury.

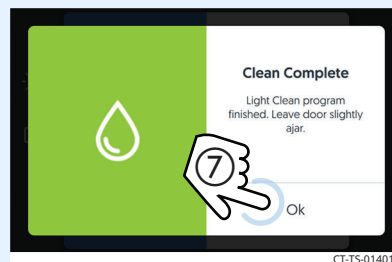

11. **Leave** the door slightly ajar if the cleaning has been done at the end of the day.



NOTE: The oven stays idle for a few minutes before turning off.

Result

The oven is now clean.

How to Descale the Catalyst

Precautions

WARNING: Burn hazard.
Wear protective gloves, protective clothing, eye protection, and face protection when handling oven cleaner. Do not open the oven door during the cleaning cycle.

NOTICE Using improper cleaning procedures will damage the catalyst and void the warranty.
For a descale catalyst cleaning cycle, use only catalyst descaler CE-47859. The use of any other cleaning chemical may damage the catalyst and void the warranty.
Do not use steel pads, wire brushes, or scrapers when cleaning.

Background

- The descale catalyst cleaning keeps the oven properly maintained.
- The descale catalyst cleaning cycle is identified with a green icon.
- The descale catalyst cleaning cycle requires three descaler packets.
- The descale catalyst cleaning does not need to be run after an oven cleaning mode.
- A descale catalyst cleaning reminder screen displays after 18 hours of cumulative cleaning (example: after four heavy cleaning cycles).

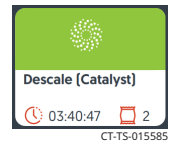

Descal the catalyst

To descale the catalyst, do the following.

Step	Action
1.	<p>Touch the menu icon ①. The menu screen displays.</p>

Continued on next page

Continued from previous page

2. **Touch** the “Cleaning” icon ②. The “Cleaning” screen displays.

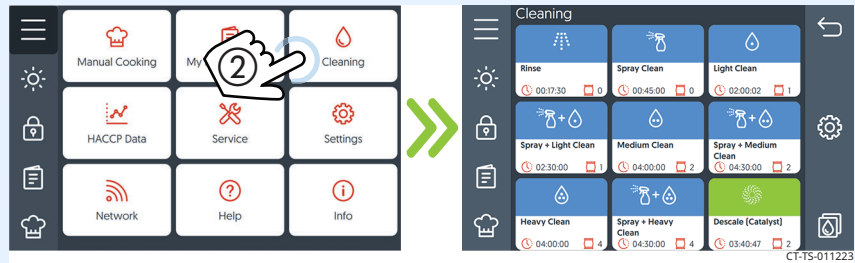

3. **Touch** the “Descal (Catalyst)” icon ③.

Distribute the contents of the descaler packets onto the jet plates equally between the chambers. Make sure to place the cleaner packets in the back right corner of the chamber.

Touch “Start” ④ to start the descale catalyst cleaning cycle.

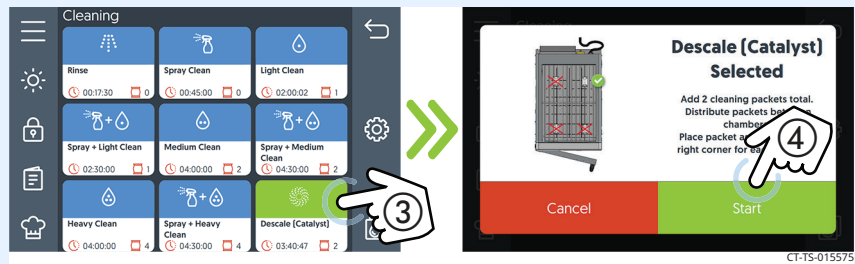

The oven heats to the required temperature for the descale catalyst cleaning cycle, then the cycle starts.

NOTE: Touching the cancel icon “X” cancels the descale catalyst cleaning cycle, and the oven starts a forced rinse. The forced rinse must complete before operating the oven.

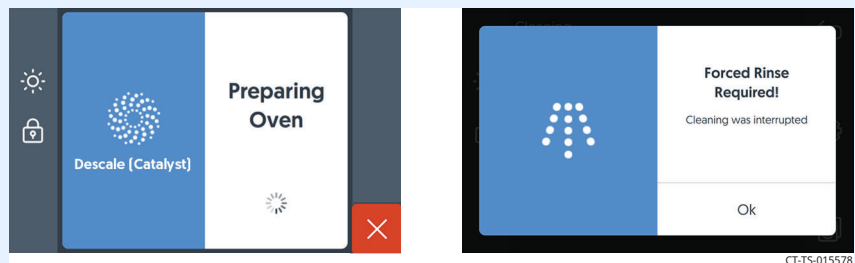

Continued on next page

Continued from previous page

4. **Touch "Ok"** ⑤ when the descale catalyst cleaning cycle is complete.



WARNING: Burn hazard.

Open the door carefully when the descale catalyst cleaning cycle is complete. Escaping hot vapors or steam can cause injury.

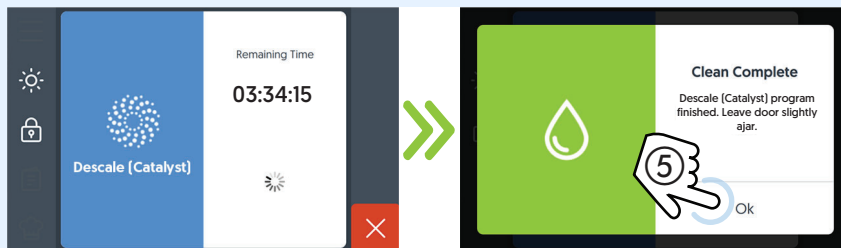

CT-TS-015582

Result

The catalyst is now descaled.



How to View the Cleaning Log

Background

The cleaning log allows the user to view details about the previously completed cleaning cycles on the unit.

Procedure

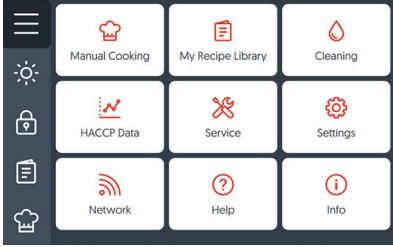
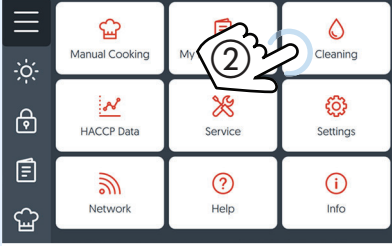
To view the cleaning log, do the following.

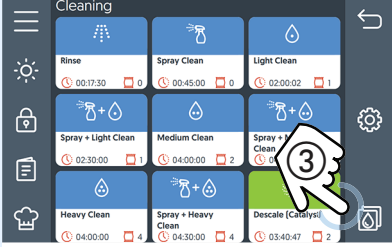
Step	Action
1.	<p>Touch the menu icon ①. The menu screen displays.</p>   <p style="text-align: right; font-size: small;">CT-TS-013849</p>
2.	<p>Touch the “Cleaning” icon ②. The “Cleaning” screen displays.</p>   <p style="text-align: right; font-size: small;">CT-TS-011223</p>
3.	<p>Touch the cleaning log icon ③. The “Cleaning log” screen displays.</p>  <p style="text-align: right; font-size: small;">CT-TS-014711</p>

NOTE: Touch the download icon ④ to download the cleaning logs to a USB drive.

Result

The cleaning log has been viewed.

How to Set the Cleaning Frequency

Background

The user can set a cleaning frequency to schedule when the unit will go through a cleaning cycle. The cleaning frequency can be set by hours or day and time.

Procedure

To set the cleaning frequency, do the following.

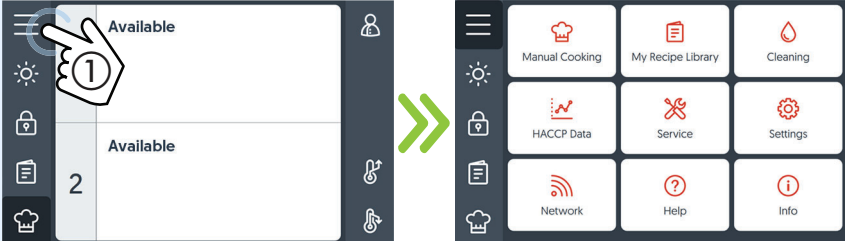
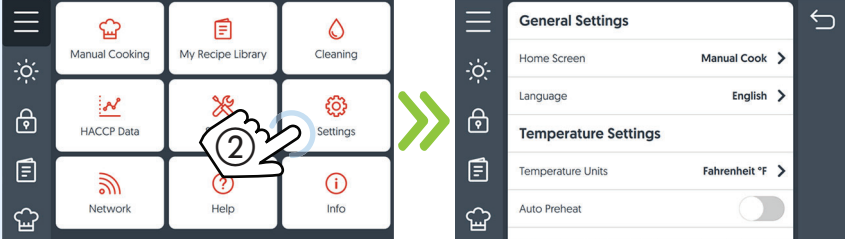
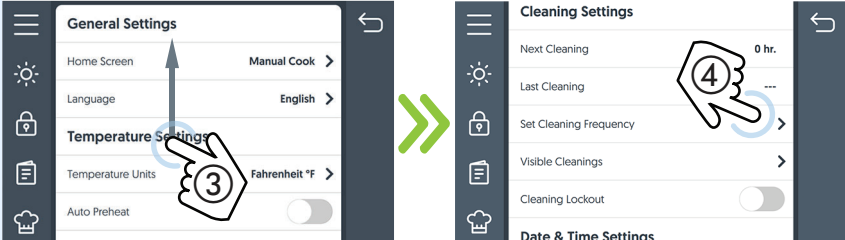
Step	Action
1.	<p>Touch the menu icon ①. The menu screen displays.</p>  <p style="text-align: right; font-size: small;">CT-TS-013849</p>
2.	<p>Touch the "Settings" icon ②. The "General Settings" screen displays.</p>  <p style="text-align: right; font-size: small;">CT-TS-013852</p>
3.	<p>Scroll ③ until "Cleaning Settings" displays. Touch the "Set Cleaning Frequency" ④ setting.</p>  <p style="text-align: right; font-size: small;">CT-TS-014721</p>

Continued on next page

Continued from previous page

Setting the cleaning frequency hours

4. **Touch** the “Hours” setting ⑤ to set the cleaning frequency hours. **Enter** the desired hours using the key pad. **Touch** the check mark.

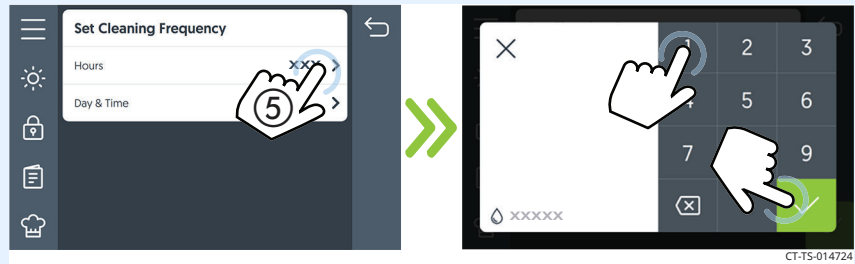

CT-TS-014724

Setting the cleaning frequency day and time

5. **Touch** the “Day & Time” setting ⑥ to set the day and time for cleaning. **Touch** the check box ⑦ next to a day to set it. **Touch** the check mark.

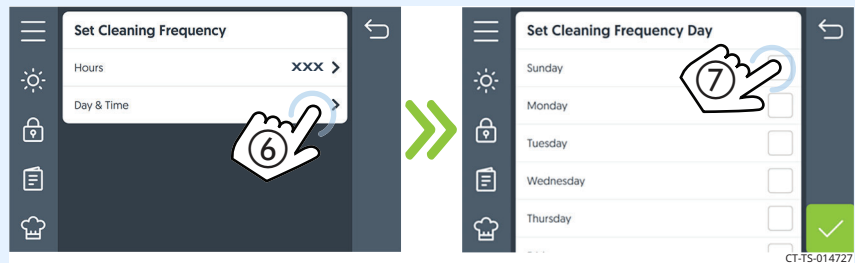

CT-TS-014727

6. The “Set cleaning frequency time” screen will display.
Touch the “AM”/“PM” button ⑧ to choose whether the cleaning time is set for AM or PM.
Enter the time of day for the cleaning. **Touch** the check mark.
Touch the check mark on the “Set Cleaning Frequency” setting screen.

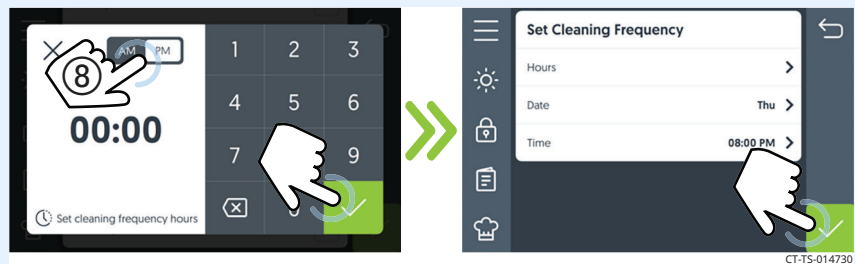

CT-TS-014730

Result

The cleaning frequency has been set.

How to Set Up Visible Cleanings

Background

Use the visible cleaning settings to display which cleaning cycles are visible on your Converge oven. By default, spray cleaning cycles are not visible on the oven interface.

Procedure

To select visible cleanings, do the following.

Step	Action
1.	<p>Touch the menu icon ①. The menu screen displays.</p> <p>CT-TS-013849</p>
2.	<p>Touch the “Settings” icon ②. The “General Settings” screen displays.</p> <p>CT-TS-013852</p>
3.	<p>Scroll ③ until “Cleaning Settings” displays. Touch the “Visible Cleanings” ④ setting.</p> <p>CT-TS-017306</p>

Continued on next page

Continued from previous page

4. **Check** the check-box ⑤ next to the cleaning cycle to hide/unhide it from the "Cleaning" screen. **Touch** the check mark ⑥.

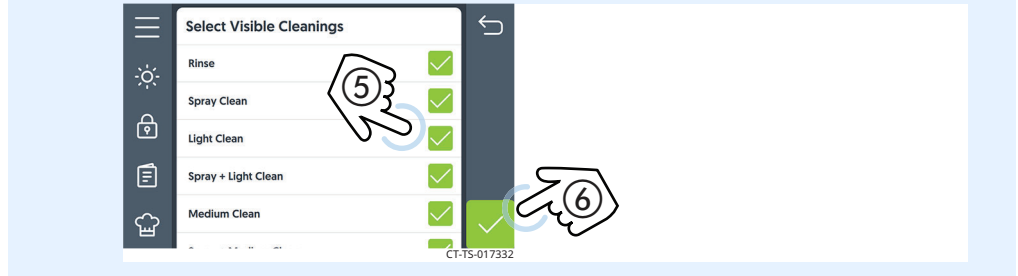

Results

Visible clean settings have now been set.

How to Set Up Cleaning Lockout

Background

Use the cleaning lockout to set up a time in which the oven will force a cleaning prior to further use.

Procedure

To set up cleaning lockout, do the following.

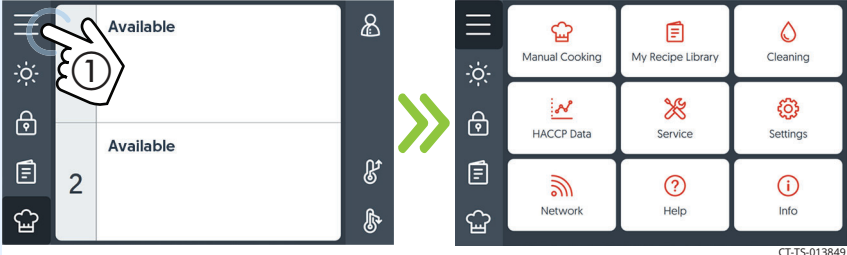
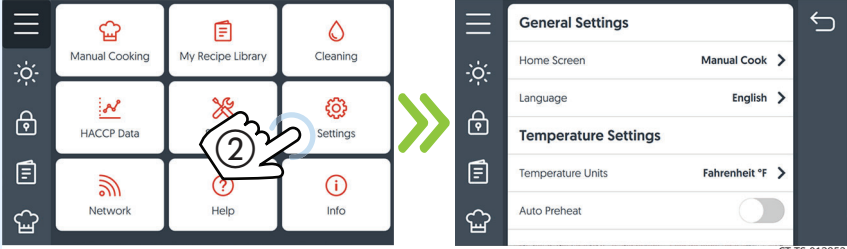
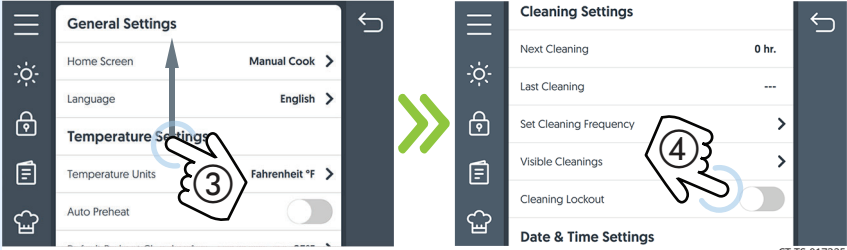
Step	Action
1.	<p>Touch the menu icon ①. The menu screen displays.</p>  <p style="text-align: right; font-size: small;">CT-TS-013849</p>
2.	<p>Touch the “Settings” icon ②. The “General Settings” screen displays.</p>  <p style="text-align: right; font-size: small;">CT-TS-013852</p>
3.	<p>Scroll ③ until “Cleaning Settings” displays. Touch the “Cleaning Lockout” ④ setting.</p>  <p style="text-align: right; font-size: small;">CT-TS-017325</p>

Continued on next page

Continued from previous page

4. **Touch** the “Delay Cleaning Lockout” ⑤ setting that appears after toggling the cleaning lockout on. **Enter** the time in hours to delay the cleaning. **Touch** the check mark.

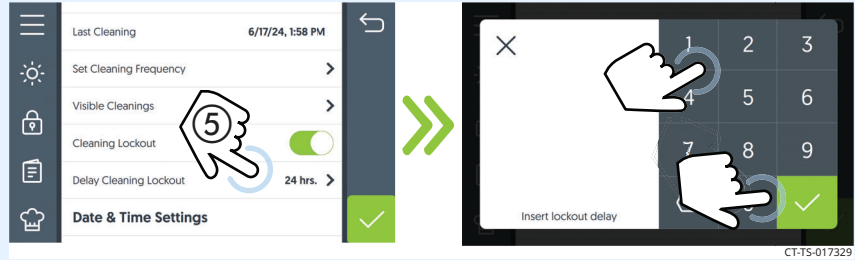

5. Once the delay has timed out, the “Oven is locked!” screen will appear. **Touch**, “Ok” ⑥. **Navigate** to the “Cleaning” screen. **Touch** the preferred cleaning cycle ⑦ and allow the cleaning cycle to run.

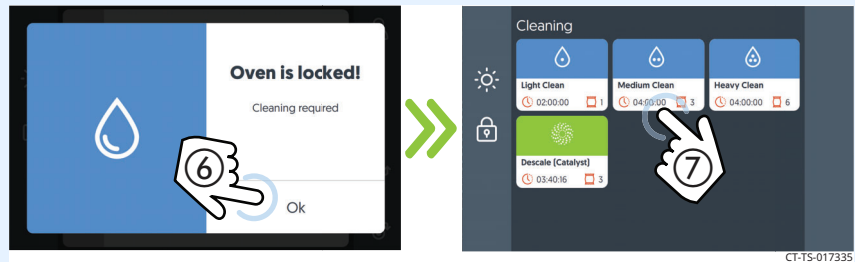

Results

Cleaning lockout has now been set.

How to Winterize the Oven

Winterization

Winterization is required if the oven is stored in a location where the ambient temperature falls below 32°F (0°C). Freezing temperatures can permanently damage internal components, especially if water is not completely drained from the unit before storage.

Winterize the oven

To winterize the oven, do the following.

Step	Action
1.	Allow the oven to cool.
2.	Drain all hoses, solenoids, and tanks (condensate and pump housing).
3.	Flush RV antifreeze through the tanks and hoses.
<div style="display: flex; align-items: center;">  <div style="margin-left: 20px;"> <p>WARNING: Poison hazard.</p> <p>Use only RV antifreeze specifically intended for potable water systems. Flush system thoroughly as directed before putting back into use.</p> </div> </div>	
4.	Inspect all hoses, and components connected to hoses, for signs or cracking or splitting.
5.	Flush cold water through each hose and each solenoid for a minimum of two minutes.
6.	Spray cold water directly into oven cavity drain for a minimum of two minutes.
<div style="display: flex; align-items: center;"> <div style="background-color: #0056b3; color: white; padding: 2px 5px; margin-right: 10px;">NOTICE</div> <p>Do not use pressurized water for this step. Use only the oven's hand shower.</p> </div>	
7.	Run a forced rinse cycle.
8.	Inspect drained water to verify all RV antifreeze has been flushed through all hoses and tanks.
9.	Run a 30-minute steam cycle and 30-minute clean cycle.

Restart the oven

Result

The oven is now ready for operation.

This page is intentionally left blank.

Error Codes

Code	Description	Parameters that trigger the error	Possible Cause(s)
E-3	Motor failure	No chamber convection motor rotation detected for greater than 30 seconds.	<ol style="list-style-type: none"> 1. Power down the control using the ON/OFF button. 2. Cycle power to the oven either by unplugging the oven or setting the main disconnect switch OFF and ON. 3. Continue operation of the oven. If the error reoccurs, contact Technical Service.
E-10	Temperature sensor short	Control board detects that the chamber sensor is shorted.	<ol style="list-style-type: none"> 1. Power down the control using the ON/OFF button. 2. Cycle power to the oven either by unplugging the oven or setting the main disconnect switch OFF and ON. 3. Continue operation of the oven. If the error reoccurs, contact Technical Service.
E-10	Food probe short	Control board detects that the probe in the chamber is shorted.	<ol style="list-style-type: none"> 1. Investigate the food probe for damage. Replace if damaged. 2. Power down the control using the ON/OFF button. 3. Cycle power to the oven either by unplugging the oven or setting the main disconnect switch OFF and ON. 4. Continue operation of the oven. If the error reoccurs, contact Technical Service.
E-11	Sensor open	Cavity air sensor reading > 650°F (343°C).	<ol style="list-style-type: none"> 1. Power down the control using the ON/OFF button. 2. Cycle power to the oven either by unplugging the oven or setting the main disconnect switch OFF and ON. 3. Continue operation of the oven. If the error reoccurs, contact Technical Service.
E-30	Unit under temperature	Cavity temperature remains 25°F (14°C) below target for more than 90 minutes.	<ol style="list-style-type: none"> 1. Was the oven preheated before loading the food? 2. Was the oven loaded with frozen food? 3. Press the high limit reset buttons. 4. Power down the control using the ON/OFF button. Turn the oven back ON and start a cook.
E-31	Electronics over temperature	Control board temperature exceeds 158°F (70°C).	<ol style="list-style-type: none"> 1. Make sure the cooling fan(s) are operating. 2. Make sure the exhaust vents are clean and free of debris. 3. Make sure the oven clearances are met. 4. Ambient temperature greater than 105°F (41°C). 5. Check the door gasket for damage and proper seal.

Code	Description	Parameters that trigger the error	Possible Cause(s)
E-31	Electronics over temperature	Interface board temperature exceeds 184°F (84°C).	<ol style="list-style-type: none"> 1. Power down the control using the ON/OFF button. 2. Cycle power to the oven either by unplugging the oven or setting the main disconnect switch OFF and ON. 3. Continue operation of the oven. If the error reoccurs, contact Technical Service.
E-31	Electronics over temperature	Chamber temperature sensor > 600°F (316°C) for Combi or Convection or chamber temperature sensor > 395°F (202°C) for Steam or Cleaning.	<ol style="list-style-type: none"> 1. If the oven has experienced an over temperature condition, allow the oven to cool down for a minimum of 30 minutes. 2. Press the high limit reset buttons. 3. Continue operation of the oven. If the error reoccurs, contact Technical Service.
E-31	Condenser temperature high	B3 sensor is higher than 212°F (100°C) for more than 180 seconds.	<ol style="list-style-type: none"> 1. Make sure the water supply line(s) is connected to the oven and that the shut off valve for the water connections is in the open position. 2. If connected to water filter(s), make sure the filters are not in need of replacement. 3. Power down the control using the ON/OFF button. 4. Cycle power to the oven either by unplugging the oven or setting the main disconnect switch OFF and ON. 5. Continue operation of the oven. If the error reoccurs, contact Technical Service.
E-50	Control board temperature error	Temperature measurement failure on the control board.	<ol style="list-style-type: none"> 1. Make sure the cooling fan(s) are operating. 2. Make sure the exhaust vents are clean and free of debris. 3. Make sure the oven clearances are met. 4. Ambient temperature greater than 105°F (41°C). 5. Check the door gasket for damage and proper seal.
E-55	Vent not open	60 seconds after the chamber venting motor is activated, the chamber vent valve did not open.	<ol style="list-style-type: none"> 1. Power down the control using the ON/OFF button. 2. Cycle power to the oven either by unplugging the oven or setting the main disconnect switch OFF and ON. 3. Continue operation of the oven. If the error reoccurs, contact Technical Service.
E-78	Under voltage	Incoming line voltage is too low (<190V) or voltage monitor output is shorted.	<ol style="list-style-type: none"> 1. Make sure the oven plug is fully seated in electrical outlet. 2. Reset the main circuit breaker for the oven. If error reoccurs, contact Technical Service.
E-79	Over voltage	Incoming line voltage is too high (>250V) or voltage monitor output is open.	<ol style="list-style-type: none"> 1. Make sure the oven plug is fully seated in electrical outlet. 2. Reset the main circuit breaker for the oven. If error reoccurs, contact Technical Service.

Code	Description	Parameters that trigger the error	Possible Cause(s)
E-94	Interface Board - Control Board communication error	No signal transfer for more than 5 seconds between the interface board and the control board.	<ol style="list-style-type: none"> 1. Make sure the oven plug is fully seated in electrical outlet. 2. Reset the main circuit breaker for the oven. If error reoccurs, contact Technical Service.
E-105	Low water pressure	Chamber low water pressure. Water pressure switch not activated. Incoming water pressure is below 7 PSI.	<ol style="list-style-type: none"> 1. Check to ensure that the water supply line(s) connected to the oven and that the shut off valve for the water connections is in the open position. 2. If connected to water filter(s) check to ensure filters are not in need of replacement. 3. Power down using ON/OFF icon.
E-108	Cooling fan over temperature	Chassis bi-metal temperature sensor over temperature 130°F (54°C).	<ol style="list-style-type: none"> 1. Make sure the cooling fan(s) are operating. 2. Make sure the exhaust vents are clean and free of debris. 3. Make sure the oven clearances are met. 4. Ambient temperature greater than 105°F (41°C). 5. Check the door gasket for damage and proper seal.
E-109	High limit error Note: Contact an authorized Alto-Shaam service partner.	Open circuit detected across high limit switch.	<ol style="list-style-type: none"> 1. If the oven has experienced an over temperature condition, allow the oven to cool down for a minimum of 30 minutes. 2. Press the high limit reset buttons. 3. Continue operation of the oven. If the error reoccurs, contact Technical Service.
E-606	Oven cleaning system failure	Convection fan error, high limit error, cavity temperature sensor open or short, or communication for at least 15 seconds during cleaning.	<ol style="list-style-type: none"> 1. Contact Technical Service. 2. Manually clean the oven. 3. Manually rinse the oven. 4. Make sure to remove cleaners before operating the oven.

What to do if the Fan Indicator Light Illuminates

Procedure

If the fan indicator light ① illuminates, do the following.

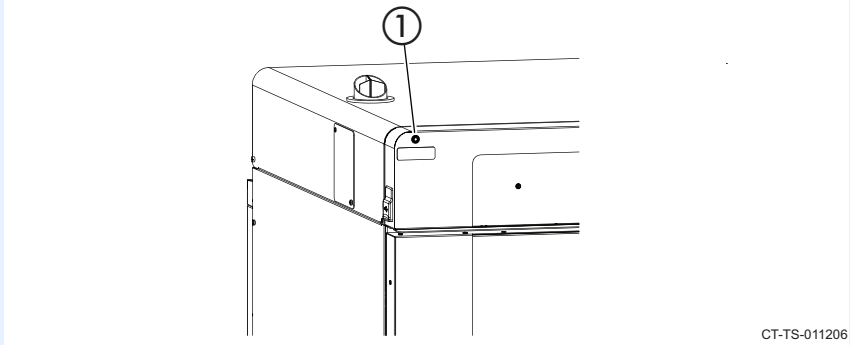
Step	Action
1.	<p>Turn off the oven and allow it to cool.</p>  <p>CT-TS-011206</p>
2.	<p>Resume operation of the oven.</p> <p>NOTE: If the fan indicator light remains on, the appliance is malfunctioning. Disconnect the appliance from the power supply and have it serviced by a qualified technician.</p>

Result

The procedure is now complete.

What to do if the High Limit Screen Displays

Procedure

If the high limit screen displays, do the following.

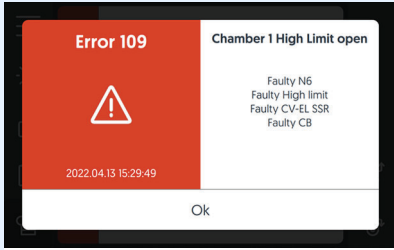
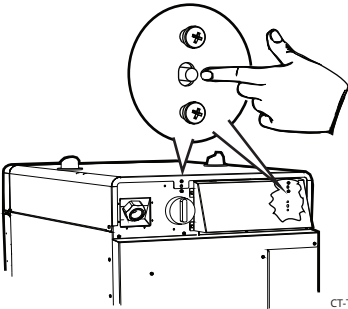
Step	Action
1.	<p>Press and release the high limit temperature reset button(s).</p> <p>NOTE: The high limit temperature reset buttons are located under the fan cover.</p> <div style="display: flex; align-items: center;">   </div> <p style="text-align: right; font-size: small;">CT-TS-013954</p>
2.	<p>Resume operation of the oven.</p> <p>NOTE: If the high limit screen continues to display, the appliance is malfunctioning. Turn off the appliance and have the oven serviced by a qualified technician.</p>

Result

The procedure is now complete.

Cheflincv2.alto-shaam.com/# is Not Available on Your Device

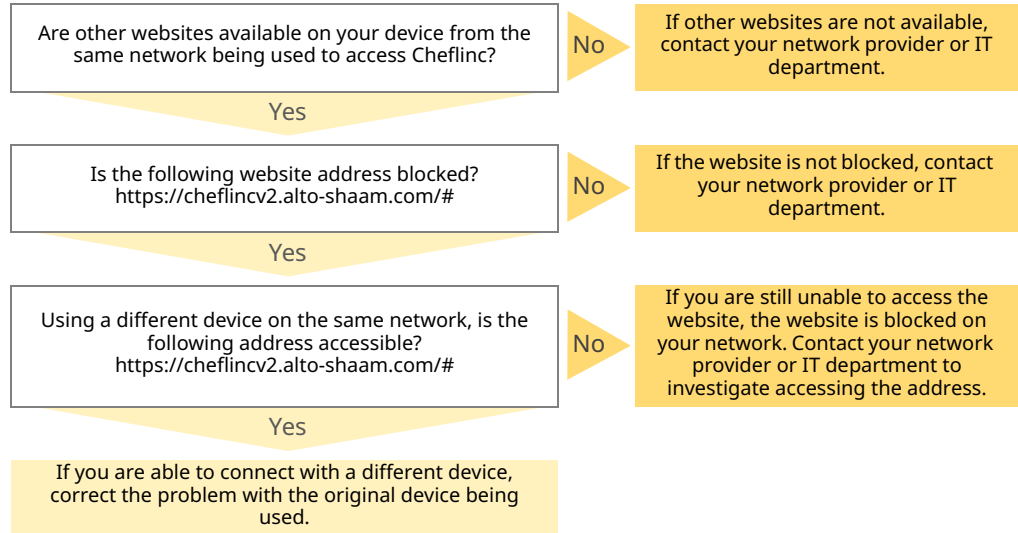

Cannot Connect to cheflincv2.alto-shaam.com/#

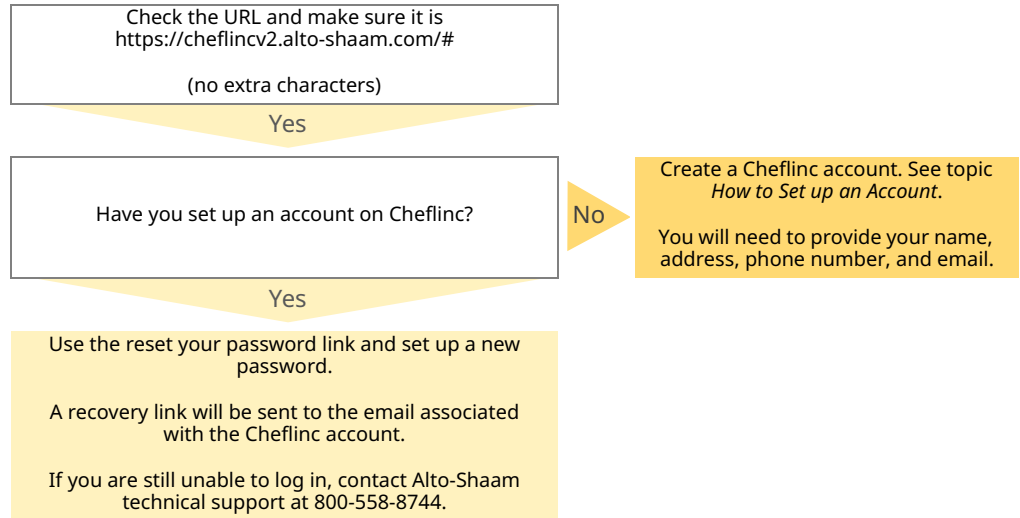

The Oven is not Displayed on the Dashboard

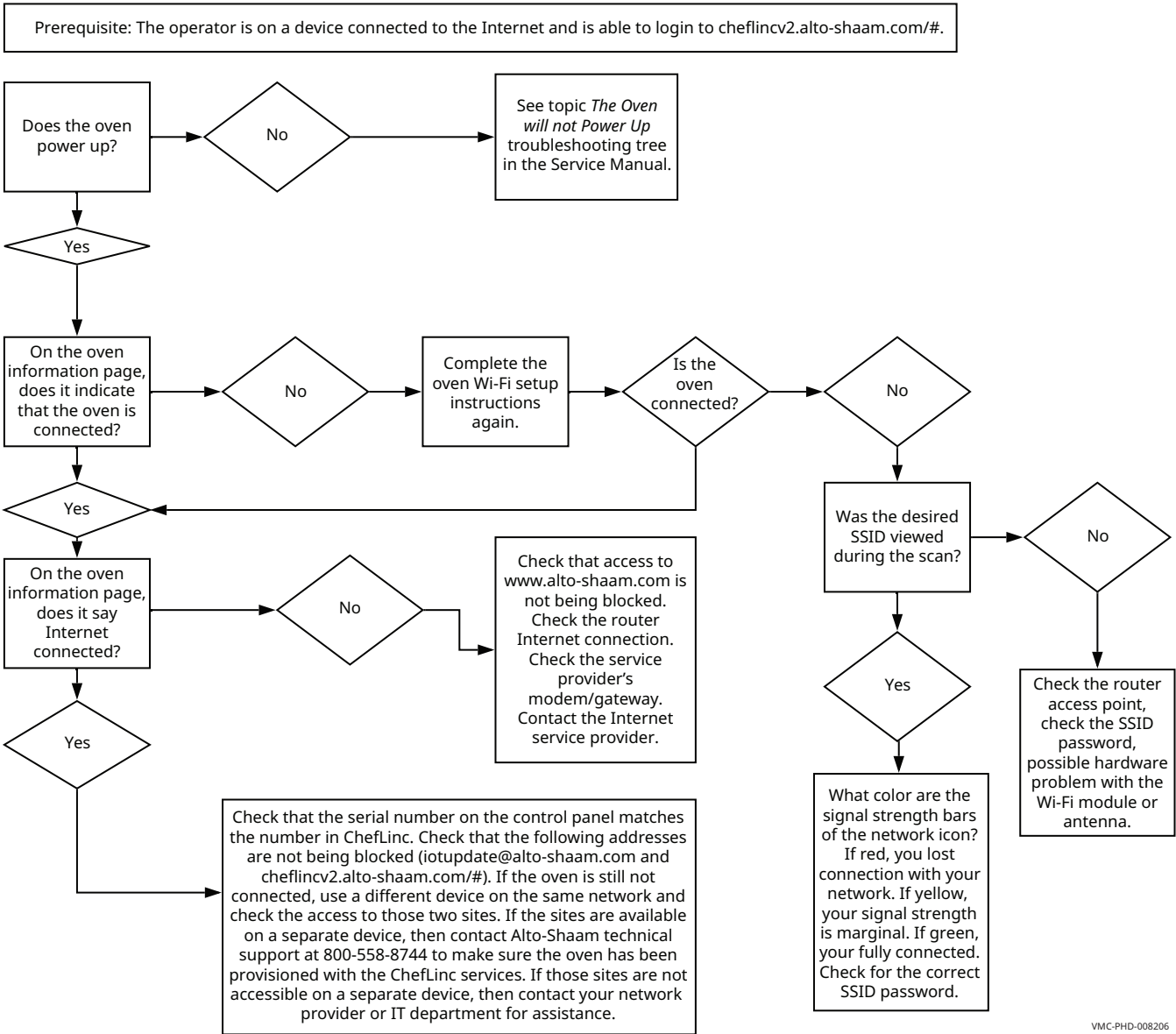

VMC-PHD-008206

Unable to Assign Recipes from the Dashboard to Ovens in the Field

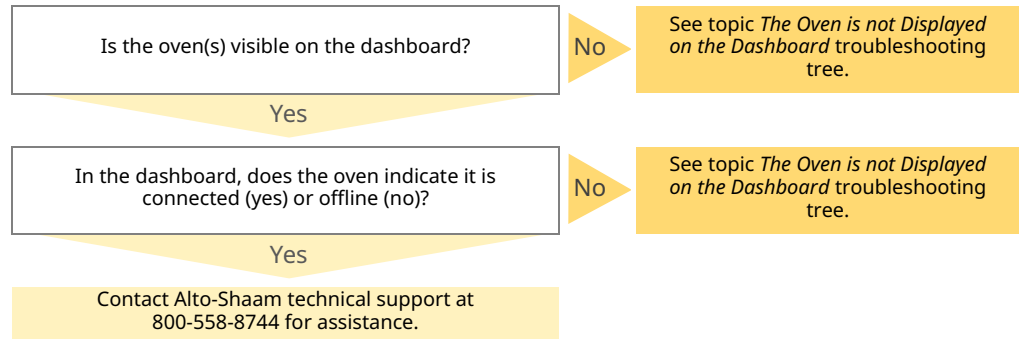

This page is intentionally left blank.

Notifications

FCC ID: N6C-SDPAC

IC ID: 4908A-SDPAC

NOTICE

Federal Communication Interference Statement (United States only)

This equipment has been tested and found to comply with the limits for a class B digital device, pursuant to Part 15 of the FCC rules. These limits are designed to provide reasonable protection against harmful interference in a residential installation. This equipment generates, uses, and can radiate radio frequency energy and, if not installed and used in accordance with the instructions, may cause harmful interference to radio communications. However, there is no guarantee that interference will not occur in a particular installation. If this equipment does cause harmful interference to radio or television reception, which can be determined by turning the equipment off and on, the user is encouraged to try to correct the interference by one or more of the following measures:

- Re-orient or relocate the receiving antenna
- Increase the separation between the equipment and receiver
- Connect the equipment to an outlet on a circuit different from that to which the receiver is connected
- Consult the dealer or an experienced radio/TV technician for help

The antenna(s) used for this transmitter must be installed to provide a separation distance of at least 20 cm from all persons and must not be co-located or operating in conjunction with any other antenna or transmitter.

**Canadian Department of Communications Industry Canada Notice
(Canada only)**

This Class B digital apparatus complies with Canadian ICES-003.

FCC Rules, Part 15 / Industry Canada

This device complies with Part 15 of FCC Rules and Industry Canada license-exempt RSS standard(s). Operation is subject to the following two conditions:

- (1) This device may not cause harmful interference, and
- (2) This device must accept any interference, including interference that may cause undesired operation of this device.

This equipment complies with FCC/IC radiation exposure limits set forth for an uncontrolled environment and meets the FCC radio frequency (RF) Exposure Guidelines in Supplement C to OET65 and RSS-102 of the IC radio frequency (RF) Exposure rules. This equipment should be installed and operated keeping the radiator at least 20 cm or more away from a person's body.

Under Industry Canada regulations, this radio transmitter may only operate using an antenna of a type and maximum (or lesser) gain approved for the transmitter by Industry Canada. To reduce potential radio interference to other users, the antenna type and its gain should be so chosen that the equivalent isotropically radiated power (e.i.r.p.) is not more than that necessary for successful communication.

This radio transmitter (identify the device by certification number, or model number if Category II) has been approved by Industry Canada to operate with the antenna types listed below with the maximum permissible gain and required antenna impedance for each antenna type indicated. Antenna types not included in this list, having a gain greater than the maximum gain indicated for that type, are strictly prohibited for use with this device.

For product available in the USA/Canada market, only channels 1–11 can be operated. Selection of other channels is not possible. If this device is to be operated in the 5.15~5.25GHz frequency range, it is restricted to indoor environments only.

Antenna: Proprietary

Antenna gain information: Embedded Antenna: 3.25dBi (2.4 GHz), 5.0dBi (5 GHz)

Frequency Tolerance: +/-20ppm

WARNING

The FCC / The Industry Canada regulations provide that changes or modifications not expressly approved by the party responsible for compliance could void the user's authority to operate the equipment.

General Specifications

Chipset:	QCA9377-3, (Qualcomm Atheros)
Host Interface:	Wifi: SDIO v3.0; BT: High Speed UART
Operating Voltage:	3.30 VDC +/- 5%
Operating Temperature:	-20 to +70 degrees C
Dimensions:	18.0 x 13.0 x 2.2 mm (L x W x D)
Connector Type:	52-pin proprietary
Radio Specifications:	802.11b/g/n: 2.412–2.484 GHz; 802.11a/n: 5.18–5.825 GHz BT: 2.402–2.480 GHz
Link Rates (1 stream):	IEEE 802.11b: 1–11 Mbps IEEE 802.11g: 6–54 Mbps IEEE 802.11a: 6–54 Mbps IEEE 802.11n HT20: 6.5–65.0 Mbps IEEE 802.11n HT40: 13.5–135.0 Mbps IEEE 802.11ac VHT20: 6.5–78.0 Mbps IEEE 802.11ac VHT40: 13.5–180.0 Mbps IEEE 802.11ac VHT80: 29.3–390.0 Mbps
Modulation Modes:	OFDM (256QAM, 64QAM, 16QAM, QPSK, BPSK), DSSS (CCK, DQPSK, DBPSK), GFSK (1Mbps), $\pi/4$ DQPSK (2Mbps), 8DQPSK (3Mbps)
Hardware Encryption:	WEP, WPA/WPA2 (TKIP/AES-CCMP), WAPI
Quality of Service (QoS):	WMM, WMM-PS, 802.11e
Japanese Security Standard	This oven cannot be connected directly to the telecommunications circuits (or public wireless LANs) of any telecommunication carriers (example: mobile communications carriers, fixed communications carriers, or Internet providers). In the case of connecting the oven to the Internet, make sure to connect it via a router.

Conditions for Ovens Installed in New York City

- Operating instructions in the manual must be read and understood by all persons using the appliance. The person responsible for training of the operators is responsible for the safekeeping of the manual.
- Prior to installation, plans specifying the exact product name/model number and dimensions/specifications shall be filed with and approved by New York City Department of Buildings (DOB). A copy of DOB docketed (Stamped, numbered and dated) plans shall be transmitted to the Fire Department for review and approval, as applicable.
- Installation, maintenance, and cleaning procedures shall comply with all applicable New York City Fire Code, New York City Electric Code, New York City Construction Codes (including the Building Code and the Mechanical Code), and rules.
- The cooking equipment shall be used for light duty cooking and food warming only, and shall be provided with catalyst to limit the emission of grease-laden air.
- The cooking equipment shall be installed in an area approved by the New York City Department of Buildings.
- Underwriters Laboratories, Inc.'s listing requirements and manufacturer's installation, operation and maintenance requirements shall be complied with.
- The cooking equipment (including filters and catalyst) shall be inspected, cleaned and replaced if necessary, by a qualified person holding a Fire Department Certificate of Fitness. The catalyst shall be maintained in proper working order. A record of such inspection and cleaning shall be kept on the premises for inspection.
- All installations are subject to inspection by representatives of the Bureau of Fire Prevention which may result in additional requirements being imposed.
- The Fire Department's condition of approval shall be provided to all New York City buyers, users and installers.
- Certificate of Approval number shall be plainly and permanently stamped or otherwise fixed upon each product by the manufacturer or the local representative of the manufacturer.
- The equipment's technology does not violate any patent, trade name, trade secret or other intellectual right.
- The Certificate of Approval does not constitute an endorsement or recommendation of the product by the Fire Department, but is a certification that the product is acceptable as of the date of issuance.
- The Fire Department may withdraw this approval at any time in the event there is a reasonable doubt that the product does not operate or perform as required by code, the conditions of the resolution or as represented in the application.
- Any end user who fails to comply with the conditions as outlined in this approval will be subject to enforcement action.

Warranty

Introduction

Alto-Shaam, Inc. warrants to the original purchaser only, that any original part found to be defective in material or workmanship will be replaced with a new or rebuilt part at Alto-Shaam's option, subject to provisions hereinafter stated.

Warranty Period

The original parts warranty period is as follows:

- For all other original parts, one (1) year from the date of installation of appliance or fifteen (15) months from the shipping date, whichever occurs first.
- The labor warranty period is one (1) year from the date of installation or fifteen (15) months from the shipping date, whichever occurs first.
- Alto-Shaam will bear normal labor charges performed during standard business hours, excluding overtime, holiday rates or any additional fees.
- For the refrigeration compressor, if installed, the warranty period is five (5) years from the date of original installation of the appliance.
- For heating elements on Halo Heat® Cook and Hold ovens, the warranty period is for as long as the original owner owns the oven. This warranty period applies to units sold after 2/1/2009 and excludes holding-only ovens.
- To be valid, a warranty claim must be asserted during the applicable warranty period. This warranty is not transferable.

Exclusions

This warranty does not apply to:

- Calibration.
- Replacement of light bulbs, rubber gaskets, grease filters, air filters, racks, jet plates, and/or the replacement of glass due to damage of any kind.
- Equipment damage caused by accident, shipping, improper installation or alteration.
- Equipment used under conditions of abuse, misuse, carelessness or abnormal conditions, including but not limited to, equipment subjected to harsh or inappropriate chemicals, including but not limited to, compounds containing chloride or quaternary salts, poor water quality, or equipment with missing or altered serial numbers.
- Equipment damage caused by use of any cleaning agents other than those recommended by Alto-Shaam, including but not limited to damage due to chlorine or other harmful chemicals.
- Any losses or damage resulting from malfunction, including loss of food product, revenue, or consequential or incidental damages of any kind.
- Equipment modified in any manner from original model, substitution of parts other than factory authorized parts, unauthorized removal of any parts including legs, or unauthorized addition of any parts.

Continued on next page

Continued from previous page

- Equipment damage incurred as a direct result of poor water quality*, inadequate maintenance of steam generators and/or surfaces affected by water. Water quality and required maintenance of steam generating equipment is the responsibility of the owner/operator.
 - Equipment damage incurred as a result of not following the required maintenance schedule published in the manuals for the equipment.
-

Conclusion

This warranty is exclusive and is in lieu of all other warranties, express or implied, including the implied warranties of merchantability and fitness for a particular purpose. No person except an officer of Alto-Shaam, Inc. is authorized to modify this warranty or to incur on behalf of Alto-Shaam any other obligation or liability in connection with Alto-Shaam equipment.

**Refer to the product spec sheet for water quality standards.*

DECLARATION OF CONFORMITY

Manufacturer:
Alto-Shaam, Inc.
W164 N9221 Water Street
Menomonee Falls, WI 53202-0450
U.S.A.



EQUIPMENT TYPE:	Household and Similar Electric Appliances
EQUIPMENT DESCRIPTION:	Commercial Electric Convection Ovens
MODEL NUMBER:	VMC-H2, VMC-H3, VMC-H4, VMC-H2H, VMC-H2HW VMC-H3H, VMC-H3HW, VMC-H4H, VMC-F3E, VMC-F4E with or without a V after the dash. CMC-H2H, CMC-H3H with or without option VH
APPLIED DIRECTIVES:	Low Voltage Directive 2014/35/EU MD (Machinery Directive) 2006/42/EC EMC – 2014/30/EC RED – 2014/53/EU
APPLIED STANDARDS:	EN 60335-1:2012+AC:2014 + A11:2014 EN 60335-2-42:2003 + A1:2008 + A11:2012 AS/NZS 60335.1:2011 + A1:2012 + A2:2014 + A3:2015. AS/NZS 60335.1:2020 EN 55014-1: CISPR 14, EN 55014-2: CISPR 14 EN 62479, EN 300 328, EN 301 489, EN 300 893



We, the undersigned, hereby declare that the equipment specified above conforms to the above Directives and Standards

Manufacturer Name:
ALTO-SHAAM INC.
NAME: Christa Pieper
TITLE: Certification Manager

SIGNATURE: 
DATE: March 4th 2022



DECLARATION OF CONFORMITY

DECLARATION OF CONFORMITY

Manufacturer:
Alto-Shaam, Inc.
W164 N9221 Water Street
Menomonee Falls, WI 53202-0450



EQUIPMENT TYPE: Household and Similar Electric Appliances

EQUIPMENT DESCRIPTION: Commercial Convection Ovens

MODEL NUMBER: VMC-H2, VMC-H2H, VMC-H2HW, VMC-H3, VMC-H3H, VMC-H3HW, VMC-H4, VMC-H4H, VMC-F3E, VMC-F4E, CMC-H2H, CMC-H3H with or without option VH

APPLIED UK REGULATIONS:

- Supply of Machinery (Safety) Regulations 2008
- Electromagnetic Compatibility Regulations 2016
- The Restriction of the Use of Certain Hazardous Substances in Electrical and Electronic Equipment Regulations 2012
- Radio Equipment Regulations 2017

APPLIED STANDARDS:

EN 60335-1:2012+AC:2014 + A11:2014
EN 60335-2-42:2003 + A1:2008 + A11:2012
EN 55014-1:2018, EN 55014-2:2016



We the undersigned, hereby declare that the equipment specified above conforms to the above Directives and Standards

Manufacturer Name:
ALTO-SHAAM INC.
NAME: Christa Pieper
TITLE: Certification Manager

SIGNATURE: 
DATE: March 4th 2022



ALTO-SHAAM

Menomonee Falls, WI U.S.A.

Phone 800-558-8744 | +1-262-251-3800 | alto-shaam.com