

## Vector<sup>®</sup> Multi-Cook Oven

Deluxe Control

VMC-H2  
VMC-H3  
VMC-H4

VMC-H2H  
VMC-H3H  
VMC-H4H

VMC-H2HW  
VMC-H3HW



### Structured Air Technology<sup>®</sup>

MN-46295-EN

REV.15  
02/26

EN

For the most current manual, visit [alto-shaam.com](http://alto-shaam.com)  
Die neueste Fassung des Handbuchs finden Sie auf [alto-shaam.com](http://alto-shaam.com)  
Pour la dernière version du manuel, visitez [alto-shaam.com](http://alto-shaam.com)  
Para obtener el manual más actual, visite [alto-shaam.com](http://alto-shaam.com)  
Ga voor de meest recente handleiding naar [alto-shaam.com](http://alto-shaam.com)



# Manufacturer's Information

---

**Copyright**

© Copyright 2/26 by Alto-Shaam, Inc.

All rights reserved.

This manual or any portion thereof may not be reproduced or used in any manner whatsoever without the express written permission of Alto-Shaam, Inc.

---

**Trademarks**

All trademarks referenced in this documentation are the property of their respective owners.

---

**Manufacturer**

Alto-Shaam, Inc.

P.O. Box 450

W164 N9221 Water Street

Menomonee Falls, WI 53052

---

**Original instructions**

The content in this manual is written in American English.

---

**Software and manual updates**

The information in this manual was current at the time of production. See [www.alto-shaam.com](http://www.alto-shaam.com) for the latest software and manual.

## Enjoy your Alto-Shaam Vector Oven!

---

### Structured Air Technology®

The Alto-Shaam Vector Oven features Structured Air Technology, giving you two, three or four ovens in one. It gives you the flexibility to simultaneously cook a variety of menu items with no flavor transfer. It provides the ability to control temperature, fan speed, and time in each individual oven chamber.

Cook up to twice the food than a traditional convection oven, with no microwaves, and no water.

## Extend Your Manufacturer's Warranty

---

### Register

Register your Alto-Shaam appliance online. Registering your appliance ensures prompt service in the event of a warranty claim.

Your personal information will not be shared with any other company.

[alto-shaam.com/warranty](http://alto-shaam.com/warranty)

## Alto-Shaam 24/7 Emergency Repair Service

---

### Call

Call 800-558-8744 to reach our 24-hour emergency service call center for immediate access to local authorized service agencies outside standard business hours. The emergency service access is provided exclusively for Alto-Shaam equipment and is available throughout the United States through Alto-Shaam's toll free number.

### Availability

Emergency service access is available seven days a week, including holidays.

This page is intentionally left blank.

Manufacturer’s Information . . . . . 2

**Foreword** . . . . . 3

    Enjoy your Alto-Shaam Vector Oven! . . . . . 3

    Extend Your Manufacturer’s Warranty . . . . . 3

    Alto-Shaam 24/7 Emergency Repair Service . . . . . 3

**Table of Contents** . . . . . 5

**Safety** . . . . . 7

    The Meaning of Signal Words . . . . . 7

    Appliance Description and Intended Use. . . . . 8

    Safety Precautions. . . . . 9

**Labels** . . . . . 13

    Label Locations . . . . . 13

**Installation** . . . . . 17

    Dimension Drawings . . . . . 17

    How to Unpack the Oven . . . . . 19

    ChefLinc Installation Checklist . . . . . 20

    How to Install the Oven (60 Hz Cord and Plug Models). . . . . 22

    How to Install the Oven (60 Hz Models Without Cords or Plugs) . . . 25

    How to Install the Oven (50/60 Hz Models Without Cords or Plugs) . 31

    How to Install the Oven on a Stand . . . . . 38

    How to Install the Oven on Casters (if required). . . . . 41

    How to Install the Jet Plates (VMC-H2HW, VMC-H3HW). . . . . 43

    How to View and Set up WiFi Connection. . . . . 46

    How to Set up an Ethernet Connection . . . . . 49

**Operation** . . . . . 53

    How to Turn On and Turn Off the Oven . . . . . 53

    How to Preheat the Oven. . . . . 54

    How to Preheat the Oven with Multiple Preheat Setpoints. . . . . 57

    How to Cook with Programmed Recipes . . . . . 61

    How to Cook in Manual Mode . . . . . 63

    How to Cook in Professional Mode . . . . . 66

    How to Use the Dual Timers . . . . . 69

    How to Lock and Unlock the Screen. . . . . 72

    How to Cool Down the Oven. . . . . 73

    How to Create a Recipe . . . . . 74

    How to Modify, Duplicate, or Delete a Recipe . . . . . 78

    How to Create a Category . . . . . 80

    How to Backup or Restore Settings with a USB Drive. . . . . 83

    How to Backup Recipes to a USB Drive . . . . . 85

|   |            |
|---|------------|
| How to Restore Recipes from a USB Drive . . . . .                               | 87         |
| How to Import Images from a USB Drive . . . . .                                 | 89         |
| How to Update Software with a USB Drive . . . . .                               | 91         |
| How to Check for and Download Available Software Updates . . . . .              | 94         |
| How to Temporarily Change Languages. . . . .                                    | 96         |
| How to Temporarily Change Temperature Units . . . . .                           | 97         |
| How to Change the Home Screen . . . . .   | 98         |
| How to Change the Temperature Scale . . . . .                                   | 100        |
| How to Change the Cooking Complete Notification Sound . . . . .                 | 102        |
| How to Enable/Disable Automatic Preheat . . . . .                               | 104        |
| How to Enable and Use the Replay Function . . . . .                             | 105        |
| How to Enable/Disable “Press and Hold” Cook Cancel function. . . . .            | 107        |
| How to Lock Recipe Editing, Manual Cooking,<br>or the Settings Screen . . . . . | 108        |
| How to View Oven Information . . . . .  | 110        |
| How to Download HACCP Data . . . . .  | 111        |
| <b>Maintenance</b>  | <b>113</b> |
| Maintenance Schedule . . . . .  | 113        |
| How to Clean the Oven. . . . .  | 115        |
| How to Set the Cleaning Frequency . . . . .                                     | 119        |
| How to View the Cleaning Log . . . . .  | 121        |
| <b>Troubleshooting</b>  | <b>123</b> |
| Error Codes . . . . .   | 123        |
| What to do if the Fan Indicator Light Illuminates. . . . .                      | 124        |
| What to do if the High Limit Screen Displays . . . . .                          | 125        |
| Cheflincv2.alto-shaam.com/# is Not Available on Your Device . . . . .           | 126        |
| Cannot Connect to cheflincv2.alto-shaam.com/#. . . . .                          | 127        |
| The Oven is not Displayed on the Dashboard. . . . .                             | 128        |
| Unable to Assign Recipes from the Dashboard to Ovens in the Field               | 129        |
| <b>Notifications</b>  | <b>131</b> |
| Notifications. . . . .  | 131        |
| Conditions for Ovens Installed in New York City . . . . .                       | 134        |
| <b>Warranty</b>   | <b>135</b> |
| Warranty. . . . .   | 135        |
| <b>Declaration of Conformity</b>  | <b>137</b> |

# The Meaning of Signal Words

This manual contains signal words where needed. These signal words must be obeyed to reduce the risk of death, personal injury, or equipment damage. The meaning of these signal words is explained below.

**DANGER**

Danger indicates a hazardous situation which, if not avoided, will result in serious injury or death.

**WARNING**

Warning indicates a hazardous situation which, if not avoided, could result in serious injury or death.

**CAUTION**

Caution indicates a hazardous situation which, if not avoided, could result in minor or moderate injury.

**NOTICE**

Notice indicates a situation which, if not avoided, could result in property damage.



**NOTE:** Note indicates additional information that is important to a concept or procedure.

# Appliance Description and Intended Use

## Structured Air Technology®

Alto-Shaam Vector's Structured Air Technology system allows for multiple, unique cooking chambers within the same oven. Air is delivered by a blower located in the rear of each cooking chamber. Air travels vertically through the jet plates into each chamber. The food product is blown with hot air from above and below. Structured Air plates at the top and bottom of the oven complete the upper and lower cooking chambers. Each cooking chamber is independent from the other and includes its own blower and heat source. The operator can select the optimal cooking temperature, air velocity, and cook time for each chamber either manually or through programmed recipes.

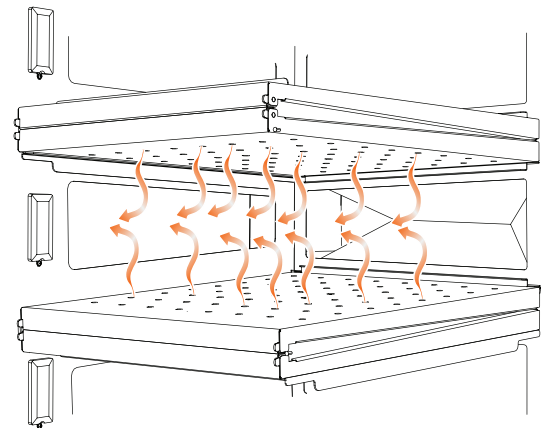
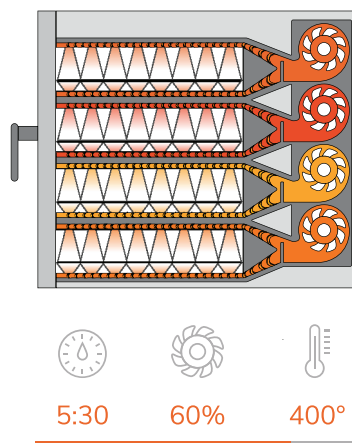

VMC-TS-000271

## Configurations

The Vector H Series is available in three configurations: two-, three-, and four-chamber.

## Intended use

The Vector series ovens are intended to cook and warm food only. Any other use is prohibited. This appliance is intended to be used for commercial applications, for example in kitchens of restaurants, canteens, hospitals and in commercial enterprises such as bakeries, butcheries, etc., but not for continuous mass production of food.

## Residual risks

This oven is manufactured using ISO-certified processes. The oven is designed with maximum safety in mind; however, there are residual risks to operators of this oven. Residual risks include exposure to heat and exposure to hot food products.

## Possible misuse

Misuse of this oven includes loading the oven with anything other than a food product. Misuse also includes heating or cooking any food product that contains alcohol or other flammable substance.

# Safety Precautions

---

## Before you begin

Read and understand all instructions in this manual.

---

## Electrical precautions

Obey these electrical precautions when using the appliance:

- Connect the appliance to a properly grounded outlet. Do not use the appliance if it is not properly grounded. Consult an electrician if there is any doubt that the outlet used is properly grounded.
  - Keep the cord away from hot surfaces.
  - Do not attempt to service the appliance or its cord and plug.
  - Do not operate the appliance if it has a damaged cord or plug.
  - Do not immerse the cord or plug in water.
  - Do not let the cord hang over the edge of a table or counter.
  - Do not use an extension cord.
- 

## Usage precautions

Obey these usage precautions when using the appliance:

- Only use this appliance for its intended use of heating or cooking.
  - Always keep liquids, or foods that can become liquid when heated, level and at or below eye level where they can be seen.
  - Use utensils and protective clothing such as dry oven mitts when loading and unloading the appliance.
  - Use caution when using the appliance. Floors adjacent to the appliance may become slippery.
  - Do not cover or block any of the openings of this appliance.
  - Do not cover racks or any other part of this appliance with metal foil.
  - Do not use this appliance near water such as a sink, in a wet location, near a swimming pool, or similar locations.
  - Do not unplug or disconnect the appliance immediately after cooking. The cooling fans must stay on to protect electrical components.
- 

## Maintenance precautions

Obey these maintenance precautions when maintaining the appliance:

- Obey precautions in the manual, on tags, and on labels attached to or shipped with the appliance.
- Only clean the appliance when oven is OFF.
- Do not store the appliance outdoors.
- Do not clean the appliance with metal scouring pads.
- Do not use corrosive chemicals when cleaning the appliance.
- Do not use a hose, water jet, or steam cleaner to clean the appliance.
- Do not use the appliance cavity for storage.
- Do not leave flammable materials, cooking utensils, or food inside the appliance when it is not in use.
- Do not remove the top cover or side panels. There are no user-serviceable components inside.

**Operator training**

All personnel using the appliance must have proper operator training. Before using the appliance:

- Read and understand the operating instructions contained in all the documentation delivered with the appliance.
- Know the location and proper use of all controls.
- Keep this manual and all supplied instructions, diagrams, schematics, parts lists, notices, and labels with the appliance if the appliance is sold or moved to another location.
- Contact Alto-Shaam for additional training if needed.

**Operator qualifications**

Only trained personnel with the following operator qualifications are permitted to use the appliance:

- Have received proper instruction on how to use the appliance.
- Have demonstrated their ability with commercial kitchens and commercial appliances.

The appliance must not be used by:

- Persons (including children) with reduced physical, sensory or mental capabilities, or lack of experience and knowledge, unless they have been given supervision concerning use of the appliance by person responsible for their safety.
- People impaired by drugs or alcohol.

- Children should be supervised to ensure that they do not play with the appliance.
- Children shall neither clean nor maintain the appliance.

**Condition of appliance**

Only use the appliance when:

- All controls operate correctly.
- The appliance is installed correctly.
- The appliance is clean.
- The appliance labels are legible.

**Servicing the appliance**

- Only trained personnel are permitted to service or repair the appliance. Repairs that are not performed by an authorized service partner or trained technician will void the warranty and relieve Alto-Shaam of all liability. Original manufacturer's replacement parts may be substituted; however, these parts must be of equal quality and specifications as those provided by Alto-Shaam.
- To prevent serious injury, death or property damage, have the appliance inspected and serviced at least every twelve (12) months by an authorized service partner or trained technician.
- Contact Alto-Shaam for the authorized service partner in your area.

**Sound power**

The A-weighted sound pressure level is below 70 dB(A).

**Personal Protective Equipment (PPE)**

Wear the following Personal Protective Equipment (PPE) while cleaning the appliance:

- Protective gloves
  - Protective clothing
  - Eye protection
  - Face protection
- 

**Use of restraining devices**

A restraining device (tether) must be installed to any appliance that is hard-wired and mounted on casters. The tether must:

- Be secured to the building's structure.
- Limit the movement of the appliance so that no stress is transmitted to the electrical conduit.

A connection point for the tether is located on the back of the appliance.

A tether is not supplied by nor available from the manufacturer.

This page is intentionally left blank.

# Label Locations

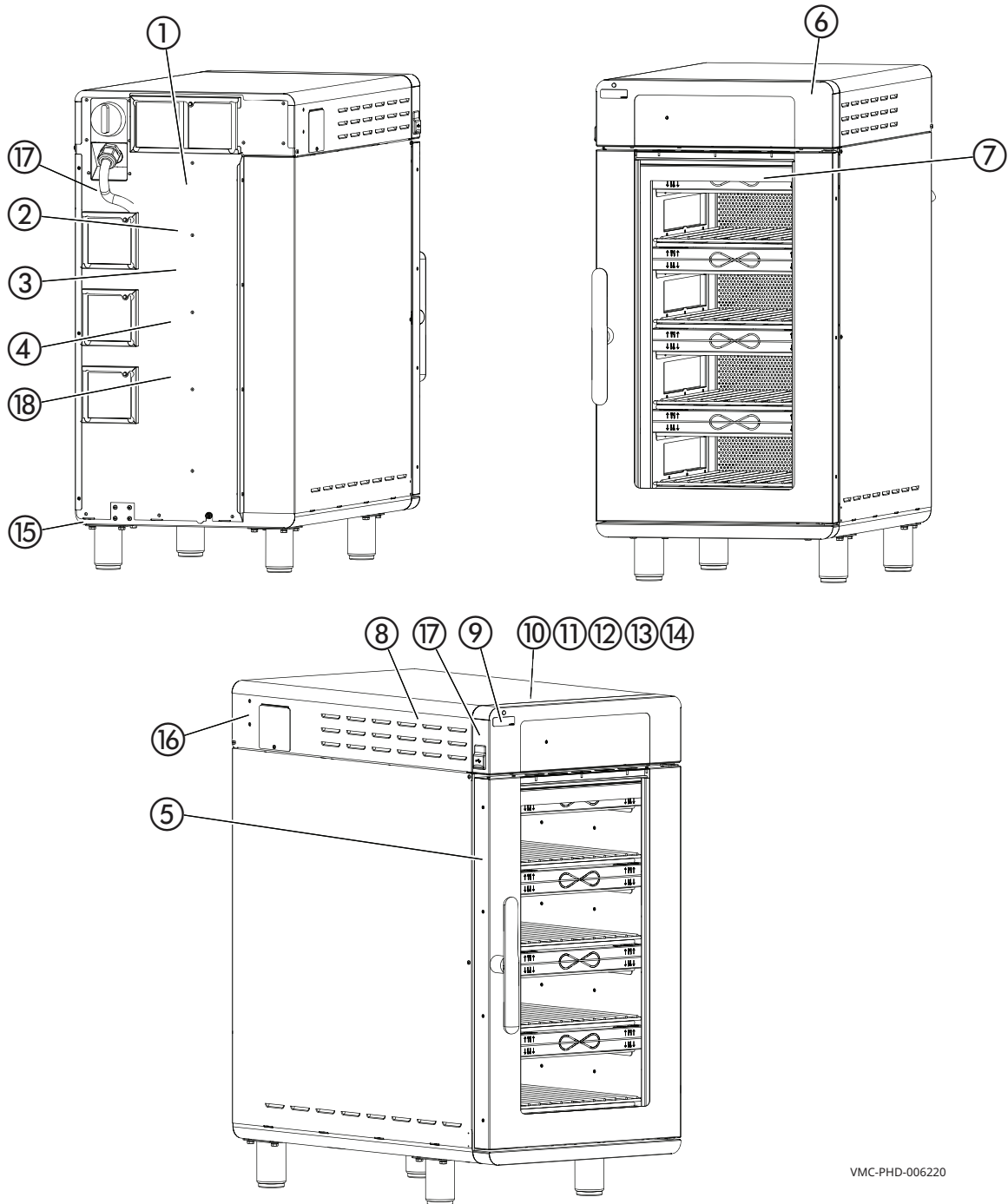

VMC-PHD-006220

LABELS

1

**⚠ WARNING/ADVERTENCIA/AVERTISSEMENT**

**Electric Shock Hazard**  
To reduce the risk of electric shock, do not remove or open cover. No user-serviceable parts inside. Refer servicing to qualified personnel. Qualified personnel: Disconnect power before servicing.

**Peligro de descarga eléctrica**  
Para reducir el riesgo de descarga eléctrica, no retire ni abra la cubierta. No hay piezas en el interior a la que se les pueda realizar mantenimiento. Derive el mantenimiento a personal calificado. Personal calificado: Desconecte la energía antes de realizar mantenimiento.

**Danger de décharge électrique**  
Pour réduire le risque de décharge électrique, ne par ouvrir ni retirer le capot. Ne contiennent pas de pièces réparables par l'utilisateur. Confier les réparations à du personnel qualifié. Personnel qualifié : Sectionnez l'alimentation avant toute intervention.

LA-38950



WARNING

Electric shock hazard

To reduce the risk of electric shock, do not remove or open the cover. No user-serviceable parts inside. Refer servicing to qualified personnel. Qualified personnel: Disconnect power before servicing.

2

Use \_\_\_\_\_ AWG for supply connections.  
Use only copper wires suitable for temperatures ≥ 90°C.  
Do not connect to a circuit operating at more than 150 VAC to ground.  
For use on individual branch circuits only.

Use AWG \_\_\_\_\_ para las conexiones de suministro.  
Use solo cables de cobre aptos para temperaturas mayores que 90 °C.  
No conecte a un circuito que funcione a más de 150 V CA a tierra.  
Para su uso en circuitos derivados individuales solamente.

Utiliser du calibre \_\_\_\_\_ AWG pour les raccordements électriques.  
Utiliser exclusivement des conducteurs en cuivre qui conviennent à des températures ≥ 90 °C.  
Ne pas raccorder à un circuit fonctionnant sous plus de 150 VCA par rapport à la terre.  
Utiliser exclusivement sur des circuits de dérivation propres.

AWG 90°C

LA-38852

**Note:** This label is only used on UL-certified appliances that have 120V to ground wiring.

Use \_\_\_\_\_ AWG for supply connections.

Use only copper wires suitable for temperature less than or equal to 90°C.

Do not connect to a circuit operating at more than 150 VAC to ground.

For use on individual branch circuits only.

3

**⚠ WARNING/ADVERTENCIA/AVERTISSEMENT**

**Fire Hazard**  
For use only on noncombustible surfaces. Maintain the correct clearances to combustibles.

**Peligro de incendio**  
Solo para uso en superficies no combustibles. Mantenga las distancias correctas de elementos combustibles.

**Risque d'incendie**  
Utilisation sur des surfaces non combustibles seulement. Maintenir des dégagements corrects par rapport aux matières combustibles.

|                        | Combustibles | Non-combustibles |
|------------------------|--------------|------------------|
| Top/above/haut         | 2" (51mm)    | 2" (51mm)        |
| Left/izquierda/gauche  | 2" (51mm)    | 2" (51mm)        |
| Right/derecho/droite   | 2" (51mm)    | 2" (51mm)        |
| Rear/posterior/arrière | 2" (51mm)    | 2" (51mm)        |

LA-38900

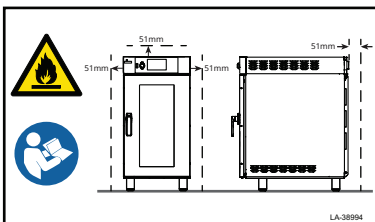

WARNING

Fire hazard

For use only on noncombustible surfaces. Maintain the correct clearances to combustibles.

4









**ALTO-SHAAM.**

Every Alto-Shaam product is precision calibrated prior to release from the factory to ensure accurate temperature control.





CALIBRATION TECHNICIAN \_\_\_\_\_

LA-26378

Every Alto-Shaam product is precision calibrated prior to release from the factory to ensure accurate temperature control.

|    |   |   |
|----|---|---|
| 5  |    | <p>WARNING<br/>Hot surface</p>  |
| 6  |    | <p>Made in U.S.A.</p>   |
| 7  | <div data-bbox="261 560 727 720"> <p><b>WARNING / ADVERTENCIA / AVERTISSEMENT</b></p> <p>Burn hazard. Always load liquids, or foods that can become liquid when heated, at an eye level where they can be seen.</p> <p>Peligro de quemaduras. Siempre coloque líquidos, o alimentos que se puedan volver líquidos cuando se calientan, a nivel de los ojos donde se puedan ver.</p> <p>Risque de brûlure. Toujours charger les liquides, ou les aliments qui deviennent liquides au chauffage, à hauteur des yeux où ils peuvent être vus.</p> <p>LA-39123</p> </div>  | <p>WARNING<br/>Burn hazard</p> <p>Always load liquids, or foods that can become liquid when heated, at an eye level where they can be seen.</p> |
| 8  |   | <p>Security seal</p>  |
| 9  | <div data-bbox="261 1062 639 1184"> <p>Check fans<br/>Compruebe los ventiladores<br/>Vérifiez les ventilateurs</p> <p>LA-39033</p> </div> <div data-bbox="261 1226 639 1348">  <p>LA-39280</p> </div>  | <p>Check fans</p>   |
| 10 |  <p>LA-36443-L1</p>  | <p>Line 1 supply terminal</p>   |
| 11 |  <p>LA-36443-L2</p>  | <p>Line 2 supply terminal</p>   |
| 12 |  <p>LA-36443-L3</p>  | <p>Line 3 supply terminal</p>   |

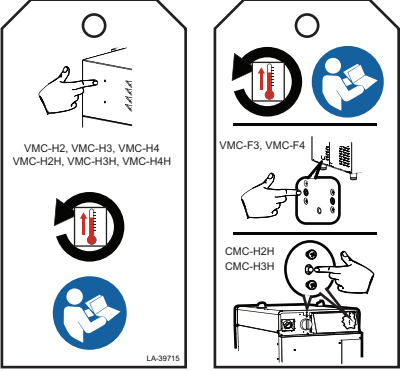
# LABELS

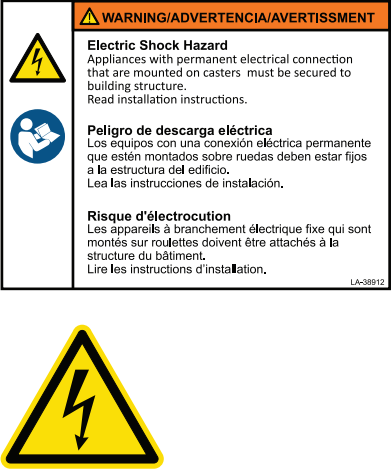
|           |   |   |
|-----------|---|---|
| <p>13</p> |  <p>LA-36443-N</p> | <p>Neutral</p>  |
| <p>14</p> |  <p>LA-36443-G</p> | <p>Ground terminal</p>  |
| <p>15</p> |  <p>LA-36443-E</p> | <p>Equipotential terminal</p>   |
| <p>16</p> |  <p>LA-39715</p>  | <p>Press and release the high limit temperature reset button(s).</p>  |
| <p>17</p> |  <p>LA-46997</p> | <p>Certificate of Approval number, Fire Department - City of New York.</p>  |
| <p>18</p> |  <p>LA-38912</p> | <p><b>WARNING</b><br/> <b>Electric Shock Hazard</b><br/>     Appliances with permanent electrical connection that are mounted on casters must be secured to building structure. Read installation instructions.</p> |



# INSTALLATION

## VMC-H2HW

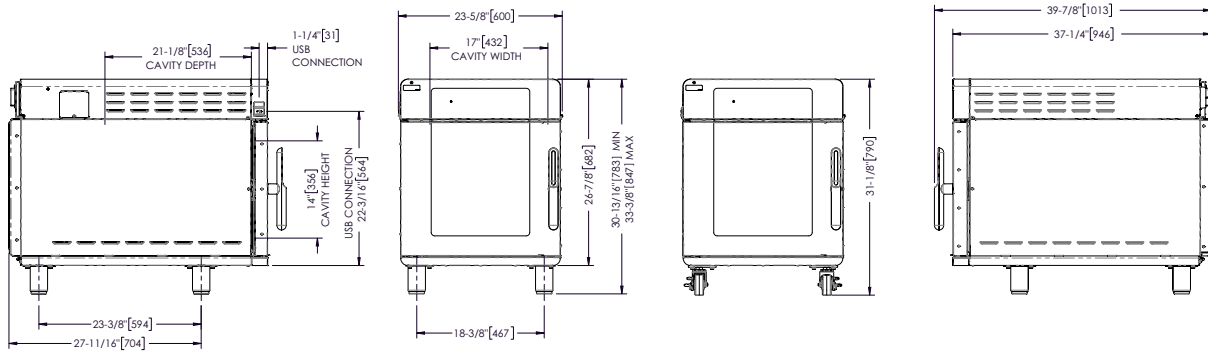
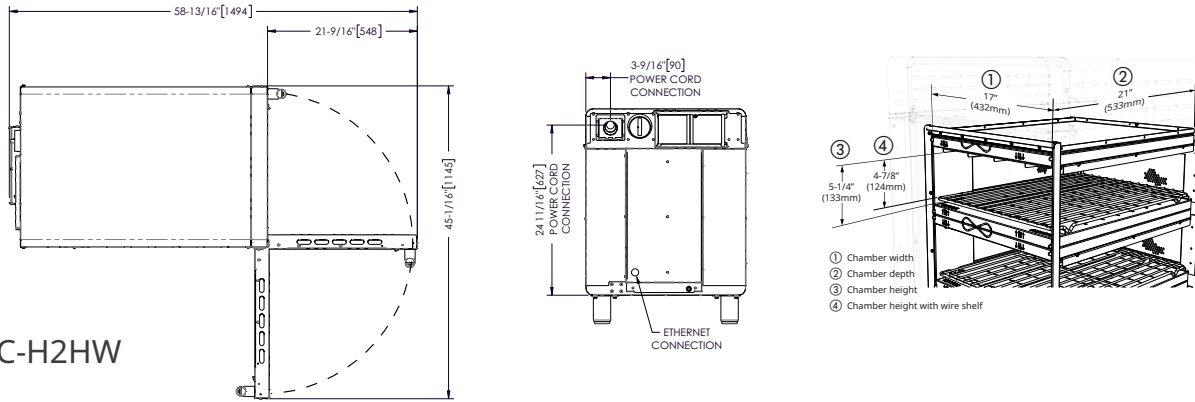

## VMC-H3HW

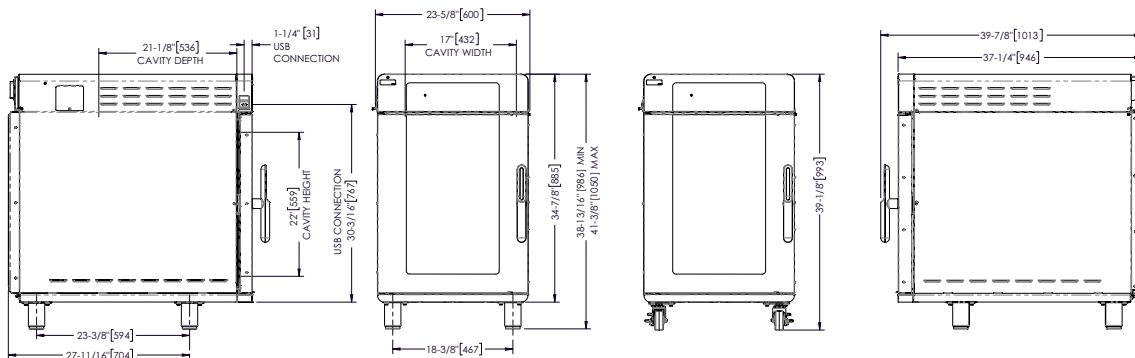
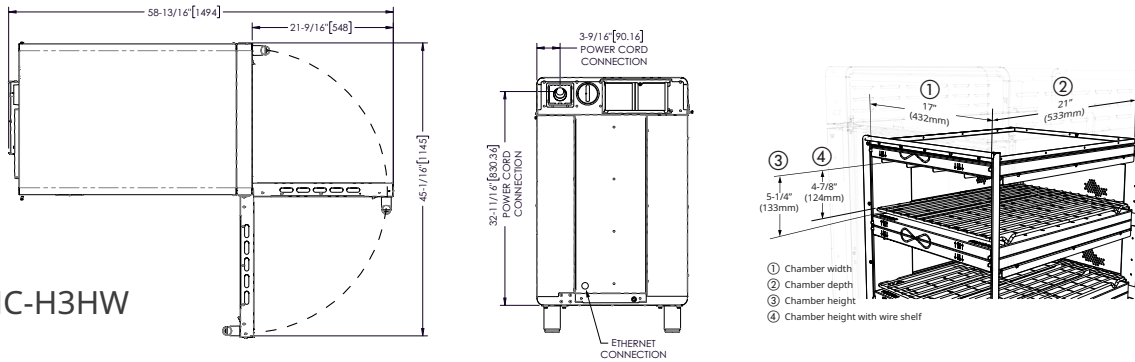

# How to Unpack the Oven

## Before you begin

### Make sure you have:

- An appropriate lifting device and enough personnel to safely move and position the weight of the oven.
  - VMC-H2/H2H: 213 lb (97 kg)
  - VMC-H3/H3H: 278 lb (126 kg)
  - VMC-H4/H4H: 348 lb (158 kg)
  - VMC-H2HW: 243 lb (110 kg)
  - VMC-H3HW: 312 lb (142 kg)
- Cutting tools to remove the packaging.

## Unpack the oven

To unpack the oven, do the following.

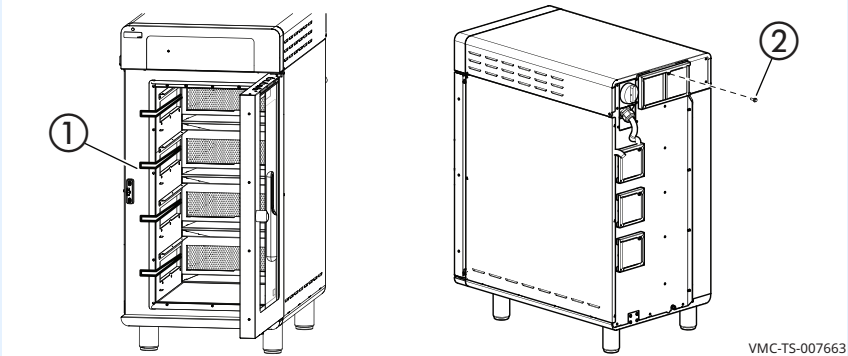
| Step  | Action   |
|---|--|
| 1.  | <b>Remove</b> the box. <b>Save</b> all packing materials for inspection by the carrier.  |
| <div style="border: 1px solid black; padding: 5px;"> <p><b>NOTE:</b> Examine the appliance for damage. If the appliance has been damaged, do not use the appliance until it has been inspected by an authorized service provider. Contact your carrier or Alto-Shaam customer service.</p> </div> |  |
| 2.  | <b>Remove</b> the shrink wrap.   |
| 3.  | <b>Cut</b> the restraining straps.   |
| 4.  | <b>Remove</b> the tape ① that holds the filters (if equipped).<br><b>Remove</b> the screws ② that holds the filters (if equipped). |
|  <p style="text-align: right; font-size: small;">VMC-TS-007663</p>  |  |
| 5.  | <b>Remove</b> the foam from each chamber.  |
| 6.  | <b>Remove</b> the oven from the pallet.  |
| 7.  | <b>Remove</b> the protective paper from the outside of the oven.   |

## Result

The oven is now unpacked.

# ChefLinc Installation Checklist

Place this form with the oven's records.

## Connectivity Pre-Installation Checklist

|  |       |          |                  |
|--|-------|----------|------------------|
| Will you connect the oven to the Internet using Wi-Fi or Ethernet? | Wi-Fi | Ethernet | Unable to answer |
|--|-------|----------|------------------|

## Wi-Fi Connections

|   |     |    |                  |
|---|-----|----|------------------|
| Is the Wi-Fi network that is to be used a WPA2 secured network?   | Yes | No | Unable to answer |
| Is this network also used to send and receive point of sale information (credit card data, register receipts)? This is NOT recommended for any installation.  | Yes | No | Unable to answer |
| Have you been provided with the network name (SSID) for the oven to connect to?   | Yes | No | Unable to answer |
| Have you been provided the password for the Wi-Fi network to be used?   | Yes | No | Unable to answer |
| At the final location that the oven will be installed, can you connect to the Wi-Fi system with your phone?   | Yes | No | Unable to answer |
| Using your phones Wi-Fi connection, are you able to connect to alto-shaam.com? You are testing for any additional security on the network to block access to external sites. You will need to turn off your cellular service on your phone to make sure you're using the Wi-Fi network. | Yes | No | Unable to answer |

## Ethernet Connections

|   |     |    |                  |
|---|-----|----|------------------|
| At the final location that the oven will be installed, is there an open Ethernet port conveniently located? | Yes | No | Unable to answer |
| Is the Ethernet port live (providing Internet access)?  | Yes | No | Unable to answer |
| Is the Ethernet harness accessory ordered with the unit?  | Yes | No | Unable to answer |

|                                |     |    |
|--------------------------------|-----|----|
| Is there site action required? | Yes | No |
|--------------------------------|-----|----|

Action required:

*Continued on next page*

Continued from previous page

**Connectivity Installation Checklist**

Refer to Network Status screen

| What is your connection type?   | Wi-Fi         | Ethernet      |
|---|---------------|---------------|
| What color is the network status icon?  | Red    Yellow | Green         |
| What is the Internet status?  | Connected     | Not connected |
| What is the cloud status?   | Connected     | Not connected |
| What is the update server status?   | Connected     | Not connected |
| What is the SSID (network name)?  |               |               |
| What is the password?   |               |               |
| What is the IP address?   |               |               |
| What is the Front End (FE) software version number?   |               |               |
| What is the Back End (BE) software version number?  |               |               |
| What is the Control Board (CB) software version number?   |               |               |
| Is this the latest software version?  | Yes           | No            |
| Validate via: <a href="https://www.alto-shaam.com/en/customer-support/software-downloads">https://www.alto-shaam.com/en/customer-support/software-downloads</a> |               |               |

# How to Install the Oven (60 Hz Cord and Plug Models)

## Before you begin

### Make sure you have:

- An appropriate lifting device, and enough personnel, to safely move and position the weight of the oven.
  - VMC-H2/H2H: 213 lb (97 kg)
  - VMC-H3/H3H: 278 lb (126 kg)
  - VMC-H4/H4H: 348 lb (158 kg)
  - VMC-H2HW: 243 lb (110 kg)
  - VMC-H3HW: 312 lb (142 kg)

## Requirements

- The oven must be installed on a level surface.
- The oven must not be installed in any area where it may be affected by steam, grease, dripping water, high temperature, or any other severely adverse conditions.
- The oven is not intended for built-in installation.

## Voltages

|                    | V   | Ph | Hz | A  | Breaker* | kW   | Plug Configuration |
|--------------------|-----|----|----|----|----------|------|--------------------|
| VMC-H2/<br>VMC-H2H | 208 | 1  | 60 | 25 | 30       | 5.2  | NEMA 6-30P         |
|                    | 240 | 1  | 60 | 28 | 30       | 6.7  | NEMA 6-30P         |
| VMC-H3/<br>VMC-H3H | 208 | 1  | 60 | 38 | 50       | 7.9  | NEMA 6-50P         |
|                    | 240 | 1  | 60 | 43 | 50       | 10.3 | NEMA 6-50P         |
|                    | 208 | 3  | 60 | 22 | 30       | 7.9  | NEMA 15-30P        |
|                    | 240 | 3  | 60 | 25 | 30       | 10.3 | NEMA 15-30P        |
| VMC-H4/<br>VMC-H4H | 208 | 3  | 60 | 33 | 40       | 10.6 | NEMA 15-50P        |
|                    | 240 | 3  | 60 | 38 | 40       | 13.9 | NEMA 15-50P        |
| VMC-H2HW           | 208 | 1  | 60 | 33 | 50       | 6.9  | NEMA 6-50P         |
|                    | 240 | 1  | 60 | 38 | 50       | 9.1  | NEMA 6-50P         |
|                    | 208 | 3  | 60 | 19 | 40       | 6.9  | NEMA 15-30P        |
|                    | 240 | 3  | 60 | 22 | 40       | 9.1  | NEMA 15-30P        |
| VMC-H3HW           | 208 | 3  | 60 | 29 | 50       | 10.5 | NEMA 15-50P        |
|                    | 240 | 3  | 60 | 33 | 50       | 13.6 | NEMA 15-50P        |

\*Electrical connections must meet all applicable federal, state, and local codes.

*Continued on next page*

Continued from previous page

## Position the oven

To position the oven, do the following.

| Step   | Action   |
|--|--|
| 1.   | <p><b>Make sure</b> that:</p> <ul style="list-style-type: none"> <li>The location where the oven is being installed is rated to support the weight of the oven;</li> <li>The oven is within five feet (1.5m) of the appropriate electrical outlet;</li> <li>You follow the oven clearance guidelines.</li> </ul> |
|  |  |
| 2.   | <p><b>Move</b> the oven to the installation location and onto the final resting surface.</p>   |

1. **Make sure** that:

- The location where the oven is being installed is rated to support the weight of the oven;
- The oven is within five feet (1.5m) of the appropriate electrical outlet;
- You follow the oven clearance guidelines.

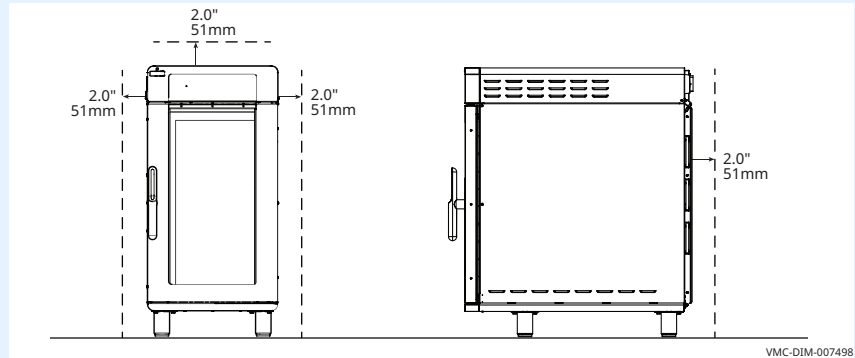

VMC-DIM-007498

2. **Move** the oven to the installation location and onto the final resting surface.

The oven is now correctly positioned.

## Level the oven

To level the oven, do the following.

3. **Check** the level of the oven using a spirit (bubble) level. Check front to back and side to side.

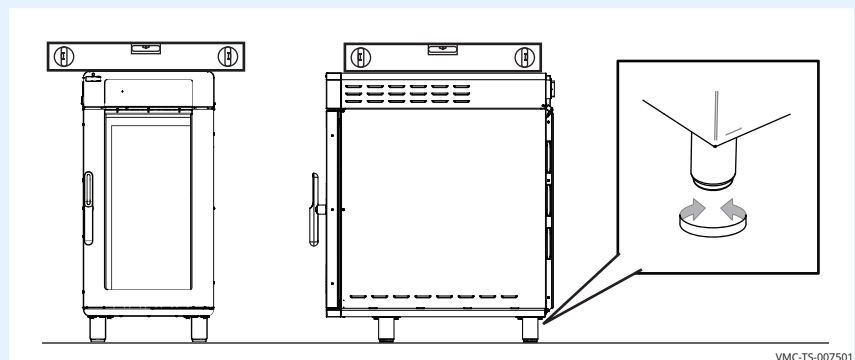

VMC-TS-007501

**Adjust** the legs, if necessary, to achieve levelness.

The oven is now correctly positioned.

Continued on next page

Continued from previous page

## Connect power

To connect electric power to the oven, do the following.

4. **Set** the main disconnect switch ① to the OFF position.

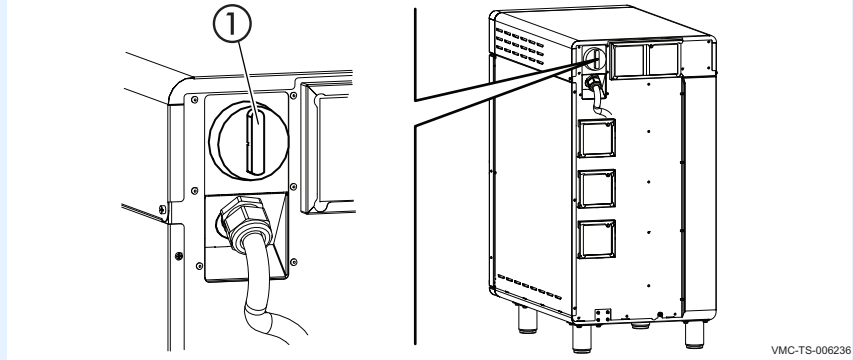

5. **Connect** the plug to the electrical outlet.

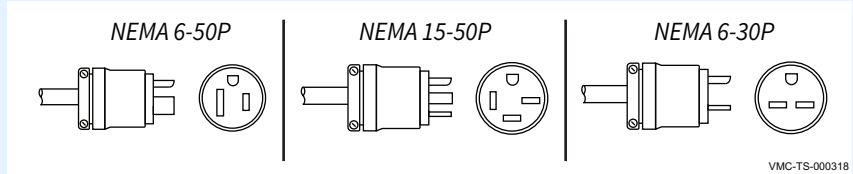

## Press reset button(s)

6. **Press and release** the high limit temperature reset button(s) ②.  
**Remove** the tag ③.

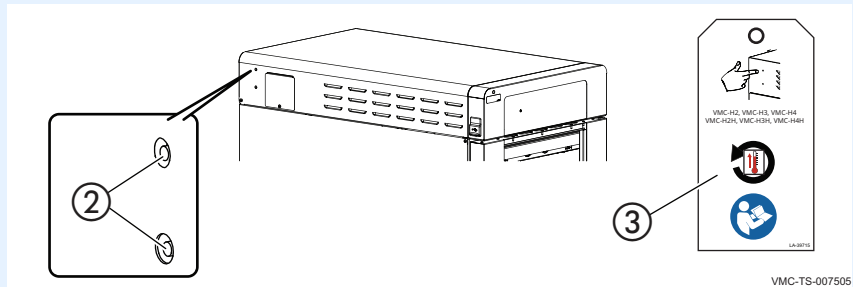

## Result

The oven is now installed and ready to be used.

# How to Install the Oven (60 Hz Models Without Cords or Plugs)

## Before you begin

### Make sure you have:

- Appropriate cord. See local codes and regulations.



**NOTE:** UL file states that the unit may be field wired. All CNL units are field wired (leakage current and input averaging); USL units may be field wired. Install appliance in accordance with local codes for that jurisdiction.

- Screwdriver (Phillips #2)
- Nut driver (1/4-inch)
- An appropriate lifting device, and enough personnel, to safely move and position the weight of the oven.
  - VMC-H2/H2H: 213 lb (97 kg)
  - VMC-H3/H3H: 278 lb (126 kg)
  - VMC-H4/H4H: 348 lb (158 kg)
  - VMC-H2HW: 243 lb (110 kg)
  - VMC-H3HW: 312 lb (142 kg)

## Requirements

- The oven must be installed on a level surface.
- The oven must not be installed in any area where it may be affected by steam, grease, dripping water, high temperature, or any other severely adverse conditions.
- The oven is not intended for built-in installation.

*Continued on next page*

Continued from previous page

## Voltages

|                    | V   | Ph | Hz    | A  | Breaker* | kW   |
|--------------------|-----|----|-------|----|----------|------|
| VMC-H2/<br>VMC-H2H | 220 | 1  | 50/60 | 25 | 32       | 5.4  |
|                    | 240 | 1  | 50/60 | 28 | 32       | 6.4  |
|                    | 380 | 3  | 50/60 | 12 | 16       | 5.4  |
|                    | 415 | 3  | 50/60 | 13 | 16       | 6.4  |
| VMC-H3/<br>VMC-H3H | 220 | 1  | 50/60 | 37 | 63       | 8.1  |
|                    | 240 | 1  | 50/60 | 41 | 63       | 9.6  |
|                    | 380 | 3  | 50/60 | 12 | 16       | 8.1  |
|                    | 415 | 3  | 50/60 | 13 | 16       | 9.6  |
| VMC-H4/<br>VMC-H4H | 380 | 3  | 50/60 | 23 | 32       | 10.8 |
|                    | 415 | 3  | 50/60 | 25 | 32       | 12.7 |
| VMC-H2HW           | 208 | 1  | 60    | 33 | 50       | 6.9  |
|                    | 240 | 1  | 60    | 38 | 50       | 9.1  |
|                    | 208 | 3  | 60    | 19 | 40       | 6.9  |
|                    | 240 | 3  | 60    | 22 | 40       | 9.1  |
| VMC-H3HW           | 208 | 3  | 60    | 29 | 50       | 10.5 |
|                    | 240 | 3  | 60    | 33 | 50       | 13.6 |

\*Electrical connections must meet all applicable federal, state, and local codes.

Continued on next page

Continued from previous page

## Position the oven

To position the oven, do the following.

| Step   | Action  |
|--|---|
| 1.   | <p><b>Make sure</b> that:</p> <ul style="list-style-type: none"> <li>The location where the oven is being installed is rated to support the weight of the oven,</li> <li>The oven is within five feet of the appropriate electrical outlet,</li> <li>You follow the oven clearance guidelines.</li> </ul> |
|  |   |
| 2.   | <p><b>Move</b> the oven to the installation location and onto the final resting surface.</p>  |

- The location where the oven is being installed is rated to support the weight of the oven,
- The oven is within five feet of the appropriate electrical outlet,
- You follow the oven clearance guidelines.

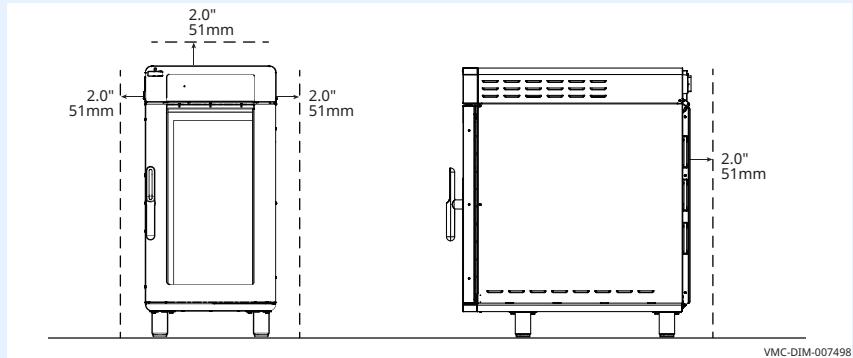

VMC-DIM-007498

The oven is now correctly positioned.

## Level the oven

To level the oven, do the following.

3. **Check** the level of the oven using a spirit (bubble) level. Check front to back and side to side.

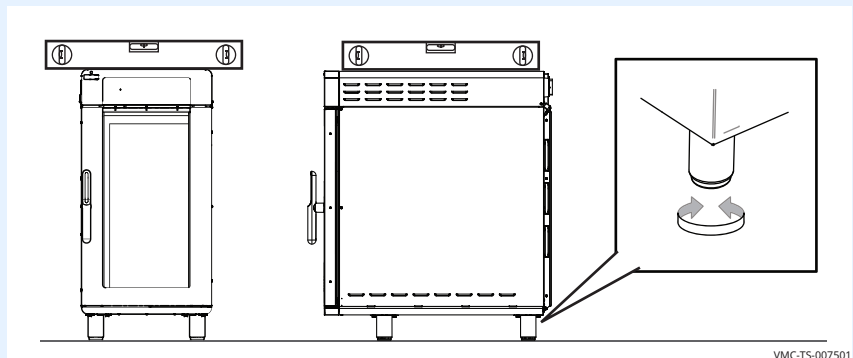

VMC-TS-007501

**Adjust** the legs, if necessary, to achieve levelness.

Continued on next page

Continued from previous page

## Connect the wiring

To connect the wiring, do the following.

4. **Remove** the pivot screws. **Remove** the top cover ①.



**WARNING:** Electric shock hazard.

Make sure the supply cord is not connected to a power supply.

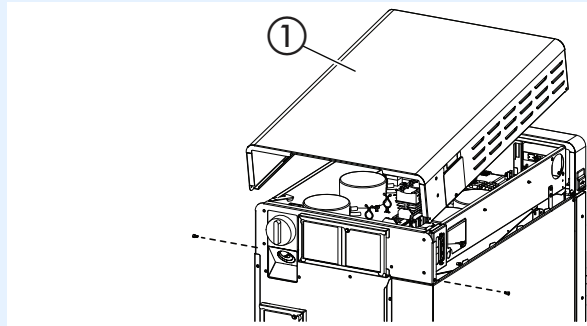

VMC-TS-007943

5. **Remove** the bottom 3 screws ② from the mounting bracket.  
**Remove** the main disconnect switch ③ from the mounting bracket.

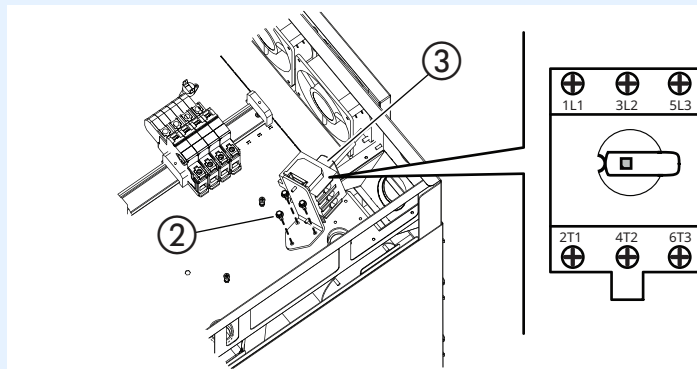

VMC-TS-001815

6. **Install** the cord ④ through the cord grip ⑤ and install to oven.  
**Install** the lock nut onto the cord grip.

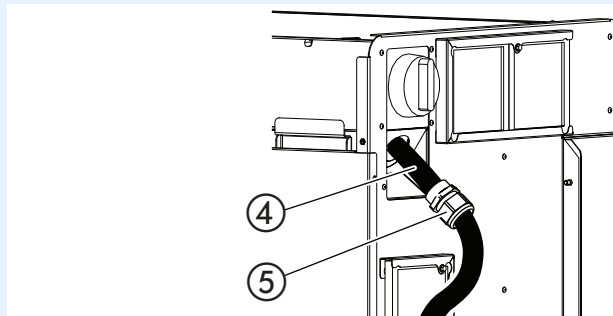

VMC-TS-007946

Continued on next page

Continued from previous page

7. **Connect** the supply cord to the appropriate terminals (L1, L2, L3, etc.) in accordance with local codes and regulations.

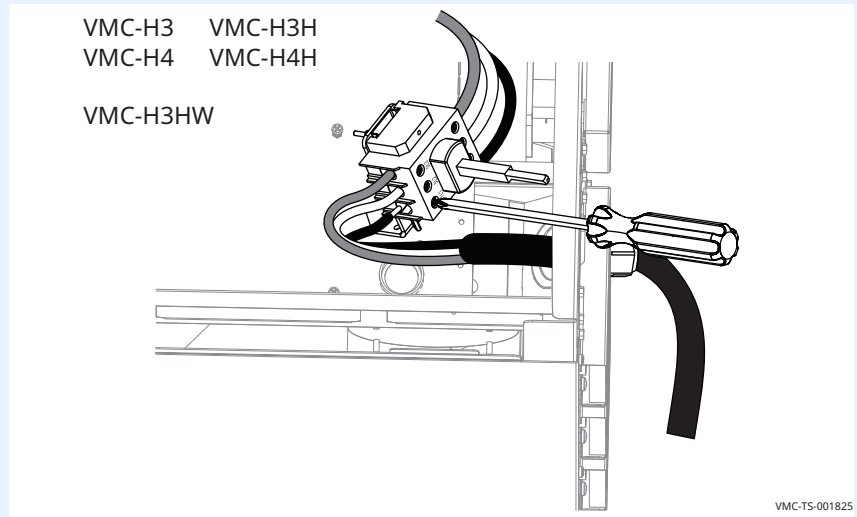
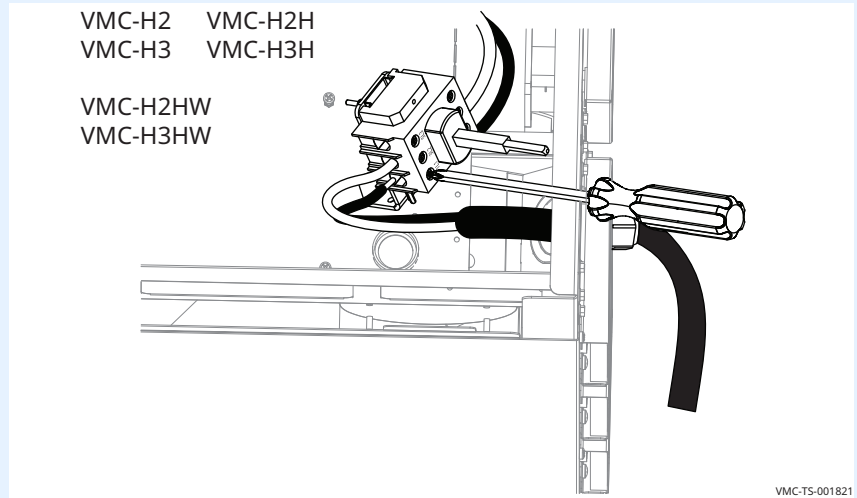

Continued on next page

Continued from previous page

8. **Install** the ground wire ⑥.  
**Adjust** the cord length.  
**Tighten** the cord grip sealing nut onto the supply cord.

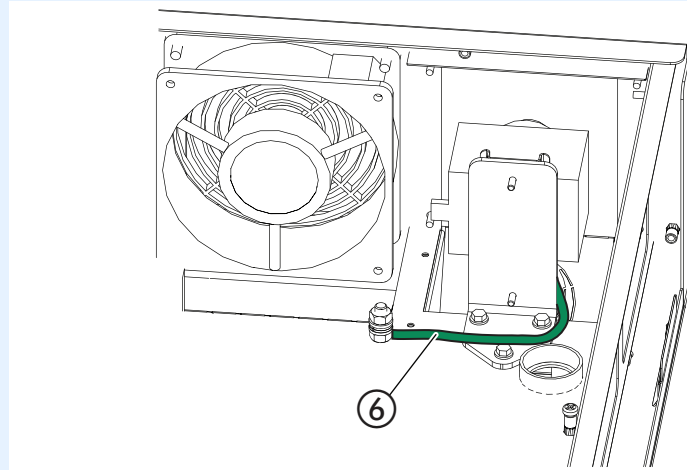

VMC-TS-001829

9. **Re-install** the main disconnect switch.
10. **Re-install** the mounting bracket.
11. **Re-install** the top cover.
12. **Press and release** the high limit temperature reset button(s) ⑦.  
**Remove** the tag ⑧.

Press reset button(s)

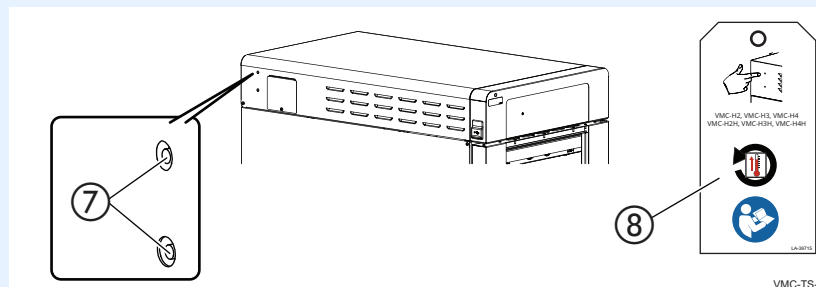

VMC-TS-007949

**Result**

The oven is now installed.

# How to Install the Oven

## (50/60 Hz Models Without Cords or Plugs)

---



**WARNING:** Electric shock hazard.

Make sure the supply cord and plug have an earth connection (ground).

### Before you begin

#### Make sure you have:

- Appropriate cord and plug, minimum oil resistant HO7RN-F. See local codes and regulations.
- Screwdriver (Phillips #2)
- Nut driver (1/4-inch)
- An appropriate lifting device, and enough personnel, to safely move and position the weight of the oven.
  - VMC-H2/H2H: 213 lb (97 kg)
  - VMC-H3/H3H: 278 lb (126 kg)
  - VMC-H4/H4H: 348 lb (158 kg)
  - VMC-H2HW: 243 lb (110 kg)
  - VMC-H3HW: 312 lb (142 kg)

### Requirements

- The oven must be installed on a level surface.
  - The oven must not be installed in any area where it may be affected by steam, grease, dripping water, high temperature, or any other severely adverse conditions.
  - If required by local codes, use Type F RCD.
  - The oven is not intended for built-in installation.
- 

*Continued on next page*

Continued from previous page

## Voltages

|                      | V   | Ph | Hz    | A  | Breaker* | kW   | Wire Size (mm) |
|----------------------|-----|----|-------|----|----------|------|----------------|
| VMC-H2H<br>220-240V  | 220 | 1  | 50    | 25 | 32       | 5.4  | 4              |
|                      | 240 | 1  | 50    | 28 | 32       | 6.4  | 4              |
| 380-415V             | 380 | 3  | 50    | 12 | 16       | 5.4  | 1.5            |
|                      | 415 | 3  | 50    | 13 | 16       | 6.4  | 1.5            |
| VMC-H3H<br>220-240V  | 220 | 1  | 50    | 37 | 63       | 8.1  | 10             |
|                      | 240 | 1  | 50    | 41 | 63       | 9.6  | 10             |
| 380-415V             | 380 | 3  | 50    | 12 | 16       | 8.1  | 1.5            |
|                      | 415 | 3  | 50    | 13 | 16       | 9.6  | 1.5            |
| VMC-H4H<br>380-415V  | 380 | 3  | 50    | 23 | 32       | 10.8 | 4              |
|                      | 415 | 3  | 50    | 25 | 32       | 12.7 | 4              |
| VMC-H2HW<br>200-240V | 200 | 1  | 50/60 | 32 | 50       | 6.5  | 8              |
|                      | 240 | 1  | 50/60 | 38 | 50       | 9.1  | 8              |
| 200-240V             | 200 | 3  | 50/60 | 18 | 40       | 6.5  | 10             |
|                      | 240 | 3  | 50/60 | 22 | 40       | 9.1  | 10             |
| 220-240V             | 220 | 1  | 50/60 | 35 | 63       | 7.7  | 10             |
|                      | 240 | 1  | 50/60 | 38 | 63       | 9.1  | 10             |
| 380-415V             | 380 | 3  | 50/60 | 20 | 32       | 7.7  | 4              |
|                      | 415 | 3  | 50/60 | 22 | 32       | 9.1  | 4              |
| VMC-H3HW<br>200-240V | 200 | 3  | 50/60 | 28 | 50       | 9.7  | 8              |
|                      | 240 | 3  | 50/60 | 33 | 50       | 13.6 | 8              |
| 380-415V             | 380 | 3  | 50/60 | 30 | 63       | 11.5 | 6              |
|                      | 415 | 3  | 50/60 | 33 | 63       | 13.6 | 6              |

\*Electrical connections must meet all applicable federal, state, and local codes.

Continued on next page

Continued from previous page

Wire sizes

60335-1 IEC:2010

| Rated current of appliance<br>A | Nominal cross-sectional area<br>mm <sup>2</sup> |
|---------------------------------|---|
| >0.2 - ≤3                       | 0.5   |
| >3 - ≤0                         | 0.75  |
| >6 - ≤10                        | 1.0   |
| >10 - ≤16                       | 1.5   |
| >16 - ≤25                       | 2.5   |
| >25 - ≤32                       | 4   |
| >32 - ≤40                       | 6   |
| >40 - ≤63                       | 10  |

Position the oven

To position the oven, do the following.

| Step | Action  |
|------|---|
| 1.   | <p><b>Make sure</b> that:</p> <ul style="list-style-type: none"> <li>■ The location where the oven is being installed is rated to support the weight of the oven,</li> <li>■ The oven is within five feet of the appropriate electrical outlet,</li> <li>■ You follow the oven clearance guidelines.</li> </ul> |
|      | <p style="text-align: right; font-size: small;">VMC-DIM-007498</p>  |
| 2.   | <p><b>Move</b> the oven to the installation location and onto the final resting surface.</p>  |

The oven is now correctly positioned.

Continued on next page

Continued from previous page

## Level the oven

To level the oven, do the following.

3. **Check** the level of the oven using a spirit (bubble) level. Check front to back and side to side.

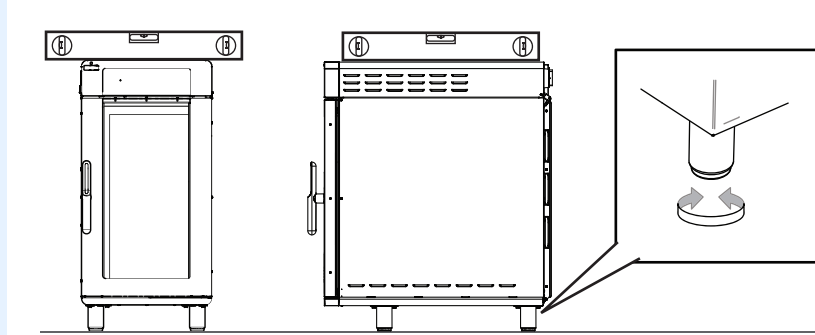

**Adjust** the legs, if necessary, to achieve levelness.

The oven is now level.

## Connect the wiring

To connect the wiring, do the following.

4. **Remove** the top cover ①.



**WARNING:** Electric shock hazard.

Make sure the supply cord is not connected to a power supply.

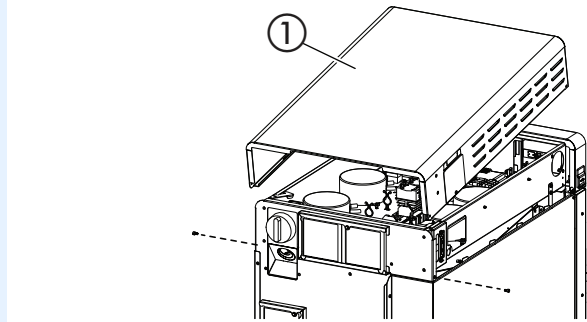

Continued on next page

Continued from previous page

5. **Remove** the bottom 3 screws ② from the mounting bracket.  
**Remove** the main disconnect switch ③ from the mounting bracket.

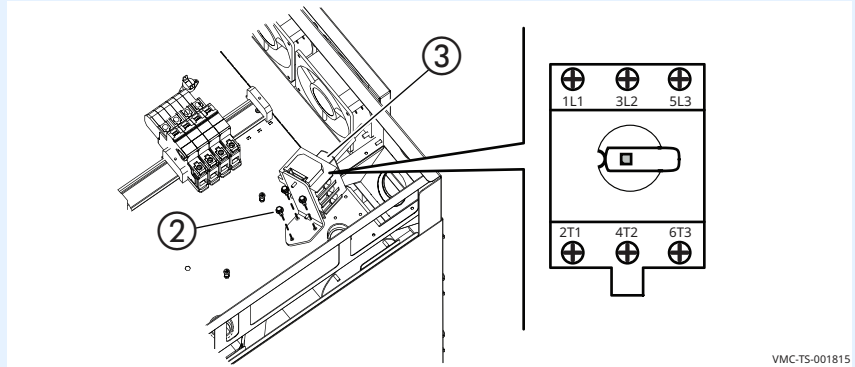

6. **Install** the cord ④ through the cord grip ⑤.  
**Install** the cord and cord grip into the oven.  
**Install** the lock nut onto the cord grip.

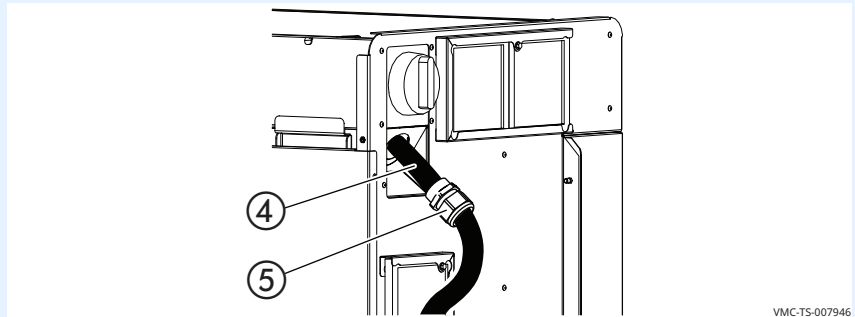

7. **Connect** the supply cord to the appropriate terminals (L1, L2, L3, etc.) in accordance with local codes and regulations.

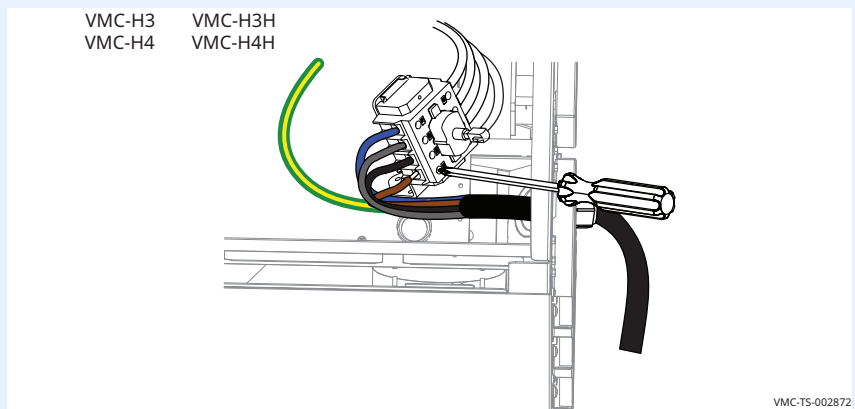

Continued on next page

Continued from previous page

8. **Install** the ground wire ⑥.

**Leave** an extra loop ⑦ so that current-carrying conductors become taut before the ground wire if the cord is accidentally pulled. Follow applicable regulations.

**Tighten** the cord grip sealing nut onto the supply cord.

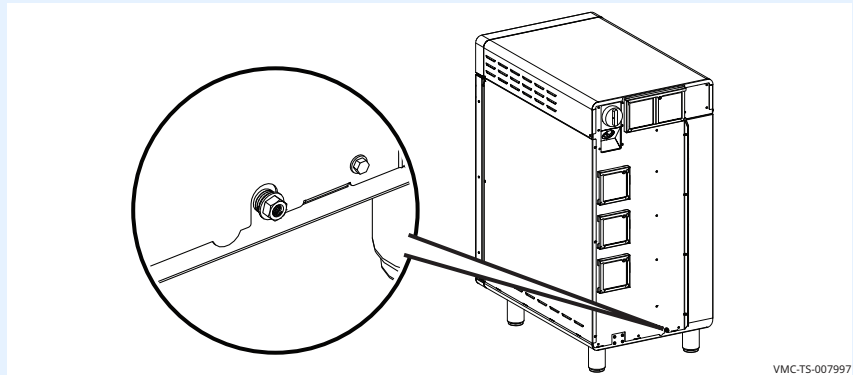
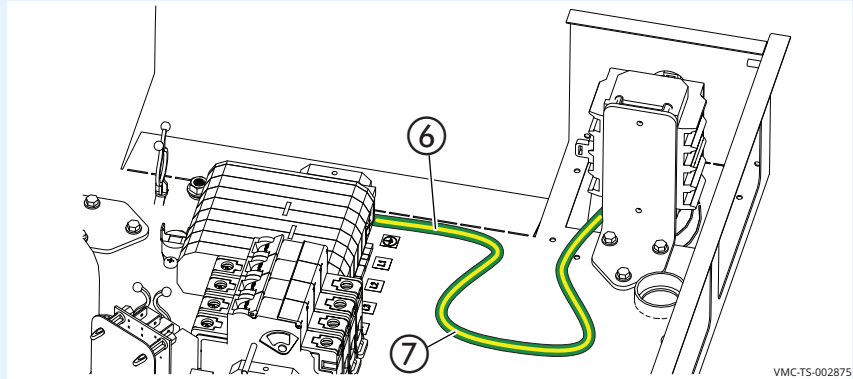

**NOTE:** The equipotential-bonding terminal is located at the bottom rear of the oven.

9. **Re-install** the main disconnect switch.
10. **Re-install** the mounting bracket.
11. **Re-install** the top cover.

Continued on next page

Continued from previous page

## Press reset button(s)

12. **Press and release** the high limit temperature reset button(s) ⑧.  
**Remove** the tag ⑨.

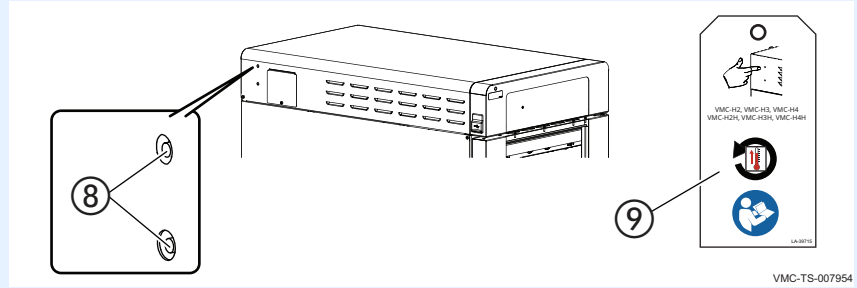

## Result

The oven is now installed.

# How to Install the Oven on a Stand

## Before you begin

### Make sure you have:

- The appropriate stand for your oven
- Regulation UL 197, 91.8
- An appropriate lifting device, and enough personnel, to safely move and position the weight of the oven.
  - VMC-H2/H2H: 213 lb (97 kg)
  - VMC-H3/H3H: 278 lb (126 kg)
  - VMC-H4/H4H: 348 lb (158 kg)
  - VMC-H2HW: 243 lb (110 kg)
  - VMC-H3HW: 312 lb (142 kg)

## Procedure

To install the oven on a stand, do the following.

| Step | Action  |
|------|---|
| 1.   | <p><b>Remove</b> the knock-outs ① that correspond to your oven. The following letters represent the oven models.</p> <ul style="list-style-type: none"> <li>■ C—Converge</li> <li>■ H—Vector H Series</li> <li>■ W—Vector Wide</li> <li>■ X—Combitherm CTX</li> </ul> |

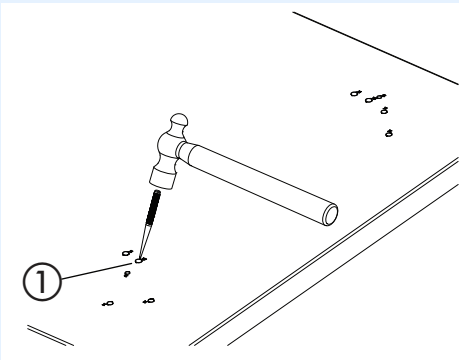
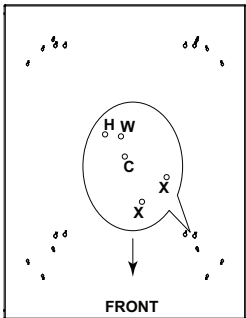
*Continued on next page*

Continued from previous page

2. **Lift** the oven using an appropriate lifting device. **Remove** the feet ②, including the mounting plates. If the unit has casters ③, remove them including the mounting plates.

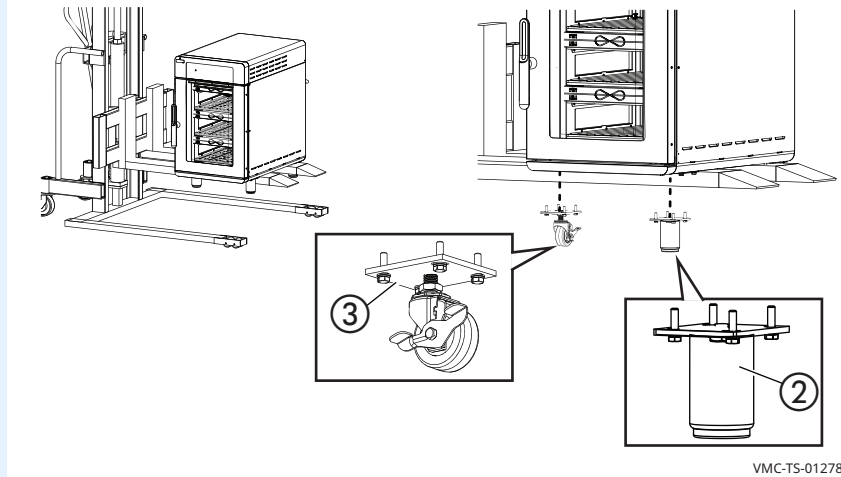

Continued on next page

Continued from previous page

3. **Orient** the oven and the stand so the front of each is pointing in the same direction.



**WARNING:** Crushing hazard.

For stands with casters, make sure to lock and block the casters when placing the oven on a stand. Consult your facility's safety manager.

**Place** the oven on the stand. Use the hole pattern ④ on the stand that corresponds to the hole pattern of the oven. The oven will use the inner most threaded holes to mount to the stand. **Connect** the oven to the stand using the hardware ⑤.

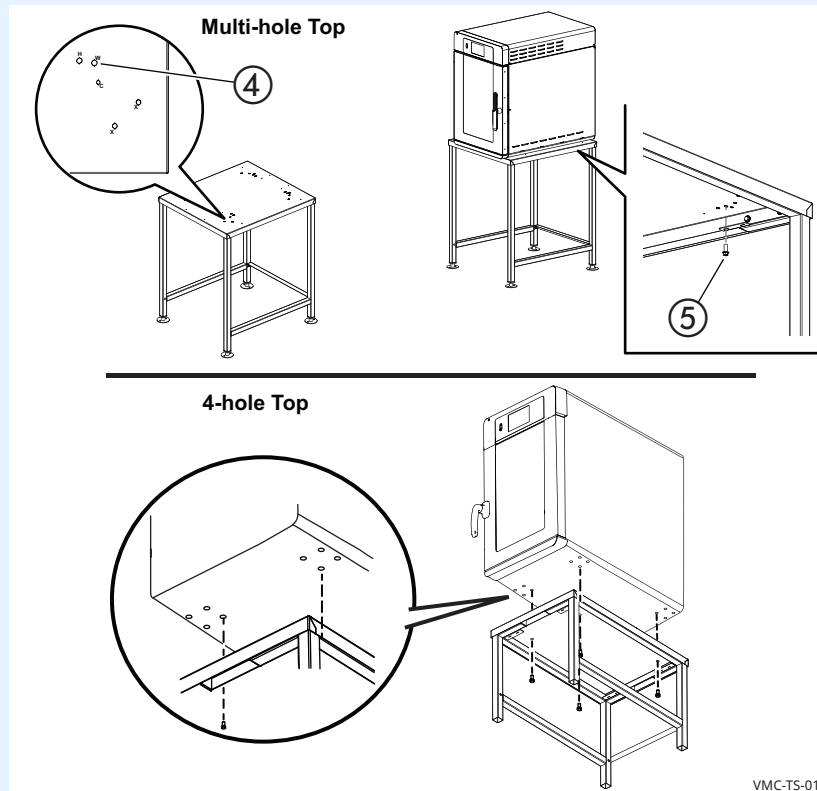

VMC-TS-012794

## Result

The oven is now installed to the stand.

# How to Install the Oven on Casters (if required)

## Before you begin

### Make sure you have:

- The appropriate stand for your oven
- Regulation UL 197, 91.8
- An appropriate lifting device, and enough personnel, to safely move and position the weight of the oven.
  - VMC-H2/H2H: 213 lb (97 kg)
  - VMC-H3/H3H: 278 lb (126 kg)
  - VMC-H4/H4H: 348 lb (158 kg)
  - VMC-H2HW: 243 lb (110 kg)
  - VMC-H3HW: 312 lb (142 kg)

## Install casters on lower oven (if required)

Some stand-oven combinations require installing casters on the oven meant to be under the stand.

To install the casters on the lower oven, do the following.

| Step | Action |
|------|--------|
|------|--------|

- |    |  |
|----|--|
| 1. | <b>Lift</b> the oven using an appropriate lifting device. <b>Remove</b> the feet ①. <b>Attach</b> each caster ② with fasteners as shown. |
|----|--|

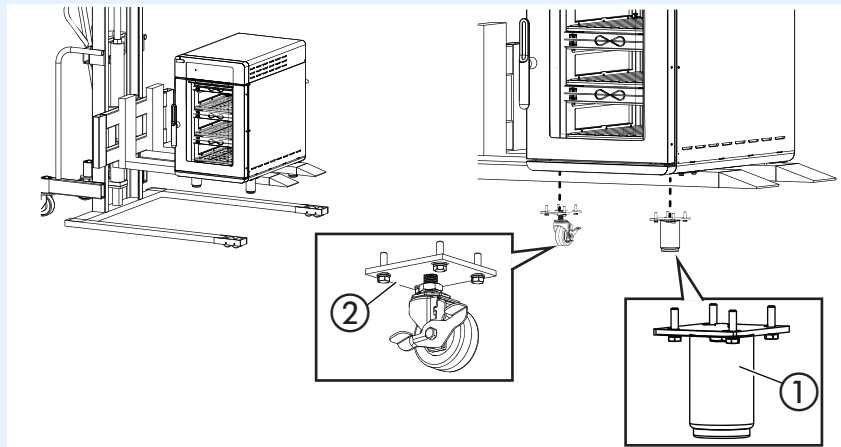

VMC-TS-010961

*Continued on next page*

Continued from previous page

2. **Level** the unit as necessary. To do so, screw the wheel up or down until the unit is level. Tighten the jam nut ③.

**Slide** a piece of the tubing ④ over the exposed screws if more than 1/4-inch of thread is exposed.

**Attach** wire tie ⑤ around the tubing to hold it in place.

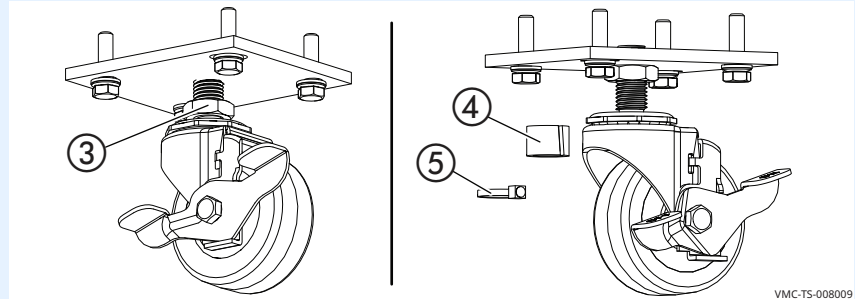

## Install the tether

3. **Install** the tether to the lower oven. Install the tether so that no stress is transmitted to the electrical cord when the oven moves.

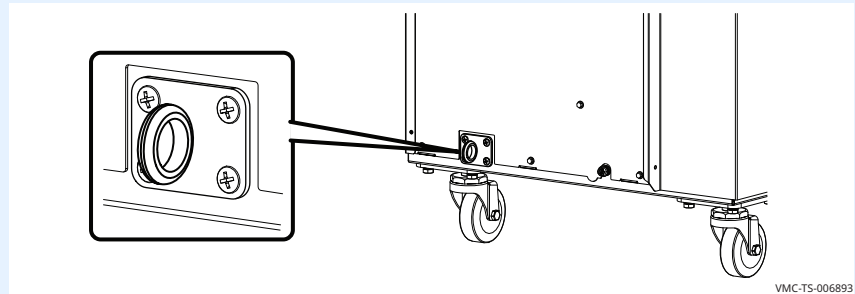

## Result

The casters are now installed.

# How to Install the Jet Plates (VMC-H2HW, VMC-H3HW)

## Background

Each jet plate assembly consists of one inner panel and one outer panel. There are two unique jet plate assemblies used on the Vector Wide oven. The difference is in the outer panel used. One type (5029095) is used on the lower section of each chamber. The other type (5030451) is used on the upper section of each chamber. The inner panels used are the same for both types of assemblies.

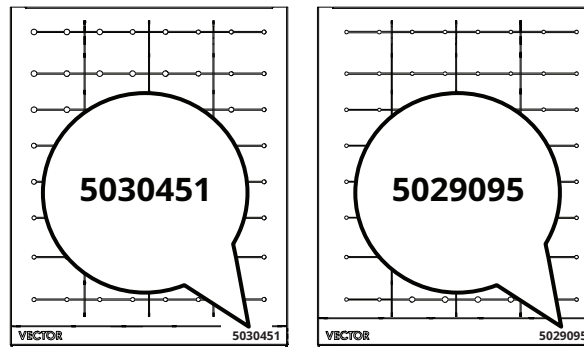

VMC-TS-014314

## Procedure

To install the jet plates, do the following.

| Step | Action   |
|------|--|
| 1.   | Each outer panel has the part number etched into the right corner. <b>Locate</b> the part number on all outer panels. <b>Place</b> an outer panel on a table with the part number facing up. |

VMC-TS-014317

*Continued on next page*

Continued from previous page

2. **Place** an inner panel on the table with the air deflector up.

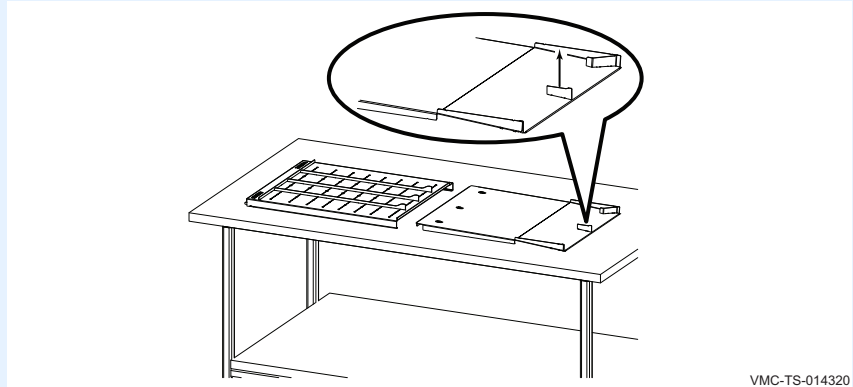

3. **Insert** the inner panel into the outer panel. **Push** the inner panel into the outer panel until it is fully inserted.

**Assemble** all jet plates in a similar fashion.

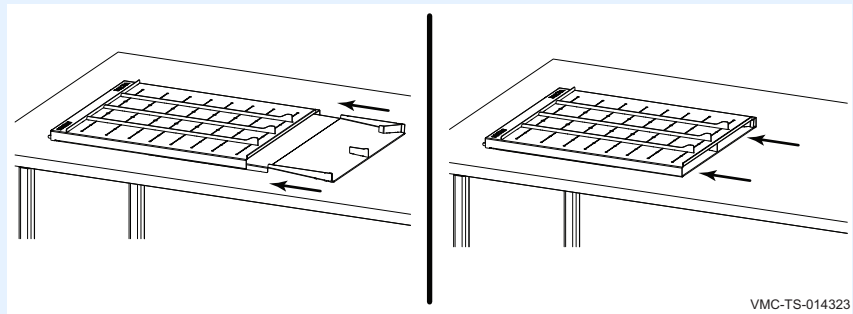

4. **Install** jet plates 5029095 in the lower section of each chamber with the part number facing up. **Install** jet plates 5030451 in the upper section of each chamber with the part number facing down.

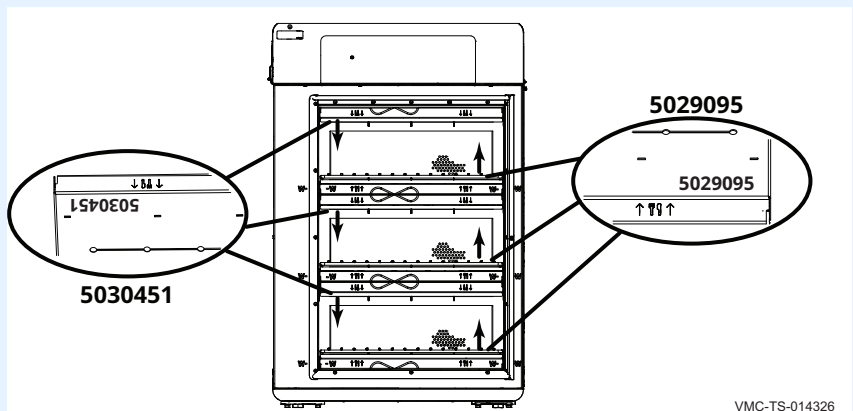

Continued on next page

Continued from previous page

5. **Follow** the steps below and inspect the installation of the jet plates.
  - Make sure the ∞ symbols are aligned.
  - Make sure the fork and knife arrows point to the product in each chamber.
  - On later production jet plates which include a "W" etched into them, make sure the "W" etched aligns with the "W" etched in the door frame.

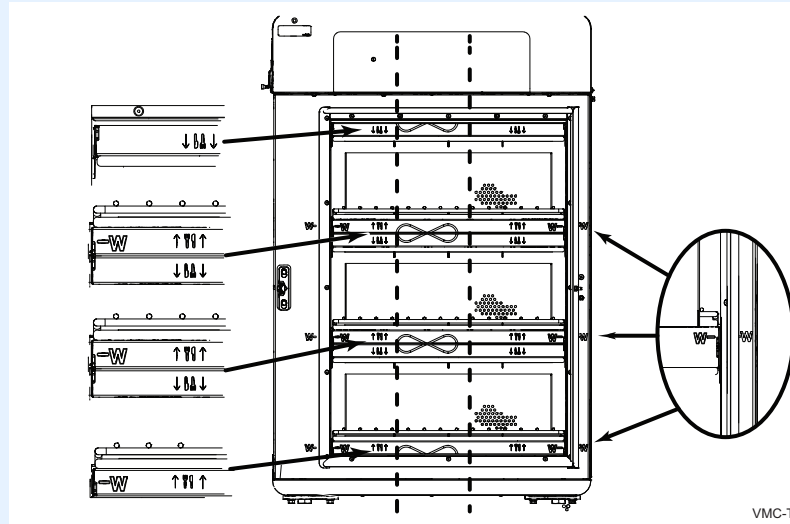

VMC-TS-014329

## Result

The jet plates are now installed.

# How to View and Set up WiFi Connection

## Before you begin

- The facility must have WiFi.
- Do not connect to a guest network.

## Procedure

To set up WiFi, do the following.

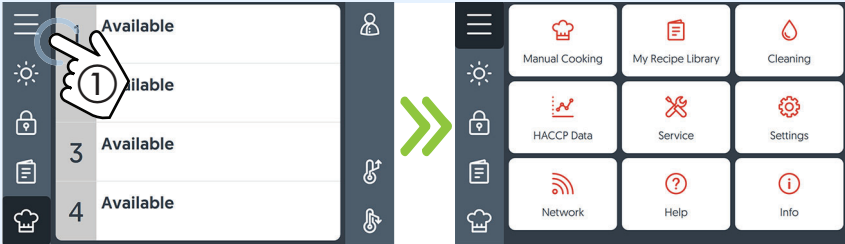
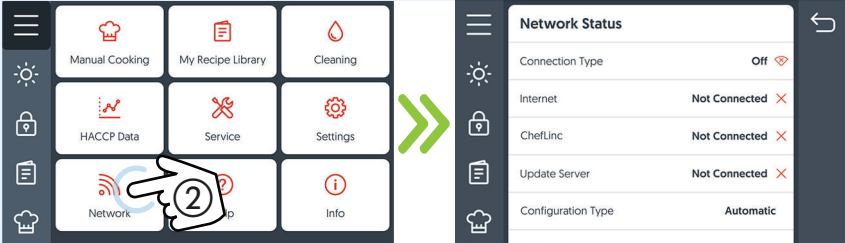
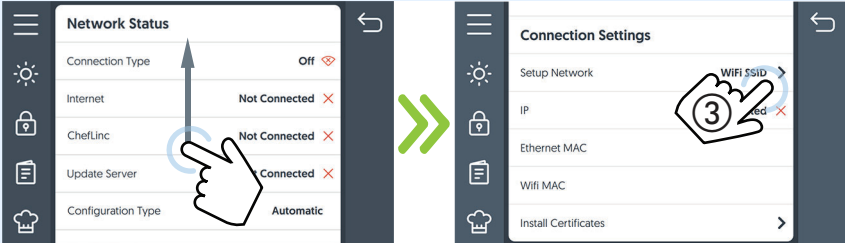
| Step | Action  |
|------|---|
| 1.   | <p><b>Touch</b> the menu icon ①. The menu screen displays.</p>  <p>VMC-TS-006259</p>                              |
| 2.   | <p><b>Touch</b> the “Network” icon ②. The “Network Status” screen displays.</p>  <p>VMC-TS-016739</p>            |
| 3.   | <p><b>Scroll</b> to “Connection Settings”. <b>Touch</b> the “Setup Network” setting ③.</p>  <p>CT-TS-013915</p> |

*Continued on next page*

Continued from previous page

4. **Touch** the “WiFi” icon ④.

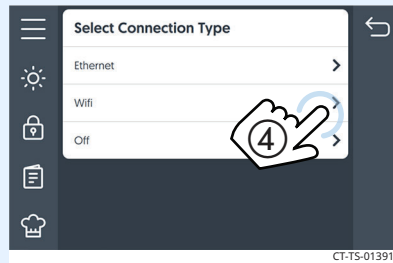

The available networks will show on the screen. The color of the network icon indicates the strength of the signal for each network.

Green = strong  
 Yellow = medium  
 Red = weak

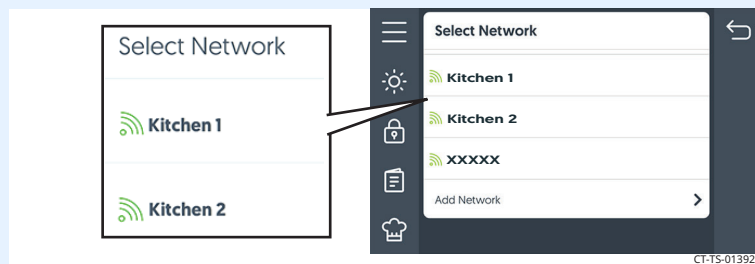

5. If the network is not displayed, **touch** the “Add Network” setting ⑤.

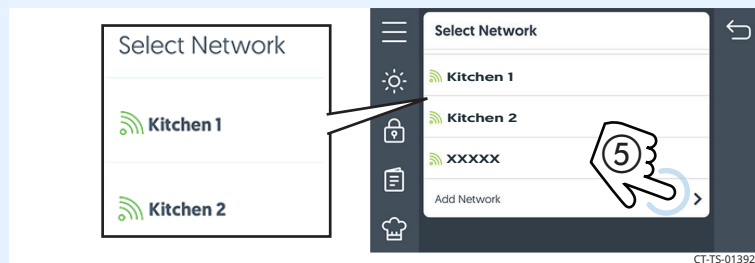

**Enter** the SSID using the keypad. Then, **touch** the check mark.

**Select** the security type.

**Enter** the password using the keypad. Then, **touch** the check mark.

Continued on next page

Continued from previous page

## Automatic IP configuration

6. For automatic IP configuration, **touch** the check mark **⑥**.

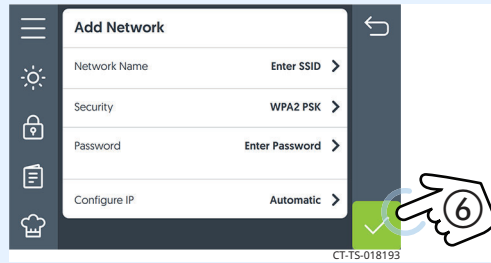

## Manual IP configuration

7. For manual IP configuration, **touch** the “Configure IP” setting **⑦**. **Touch** “Manual” **⑧** and follow the prompts.

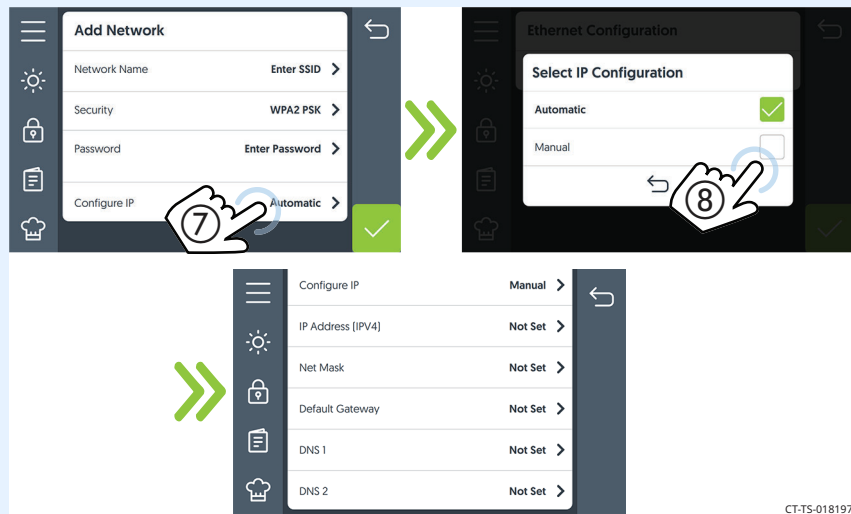

8. **Touch** the check mark when finished.

**NOTE:** If there are connection problems, touch the “ChefLinc” setting to address ChefLinc connectivity. For server connection issues, touch the “Update Server” setting.

## Result

The procedure is now complete.



# How to Set up an Ethernet Connection

**Before you begin**

- The facility must have an Ethernet port.
- You will need an Ethernet cable.

**Procedure**

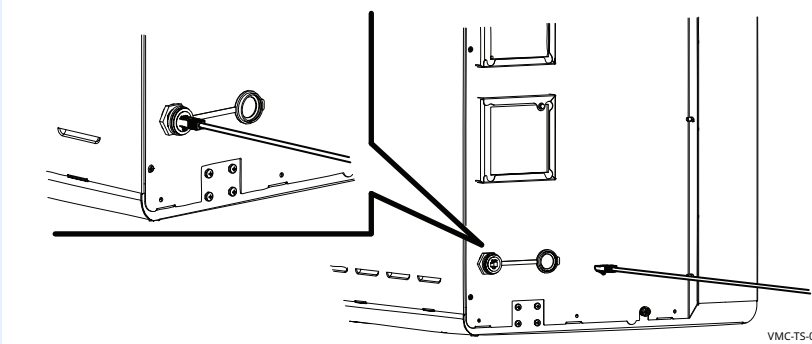
To set up an Ethernet connection, do the following.

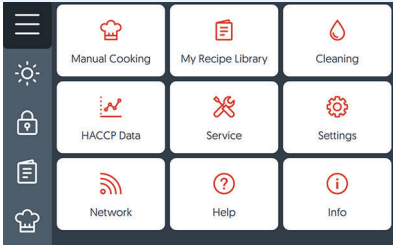
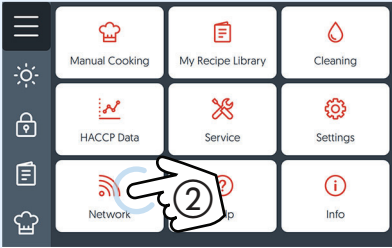
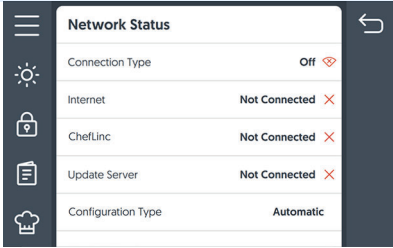
| Step | Action  |
|------|---|
| 1.   | <p><b>Plug</b> the Ethernet cord into the Ethernet port on the oven and the wall outlet.</p>  <p style="text-align: right; font-size: small;">VMC-TS-012782</p>   |
| 2.   | <p><b>Touch</b> the menu icon ①. The menu screen displays.</p>   <p style="text-align: right; font-size: small;">VMC-TS-006259</p>                  |
| 3.   | <p><b>Touch</b> the "Network" icon ②. The "Network Status" screen displays.</p>   <p style="text-align: right; font-size: small;">VMC-TS-016739</p> |

*Continued on next page*

Continued from previous page

4. **Scroll** to “Connection Settings”. **Touch** the “Setup Network” setting ③.

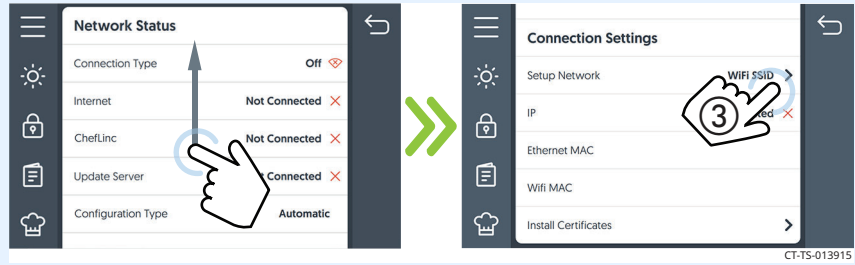

5. **Touch** the “Ethernet” setting ④. The “Ethernet Configuration” screen displays.

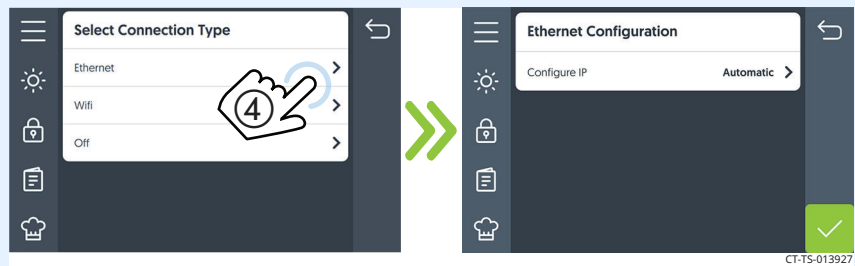

## Automatic IP configuration

6. For automatic IP configuration, **touch** the check mark ⑤.

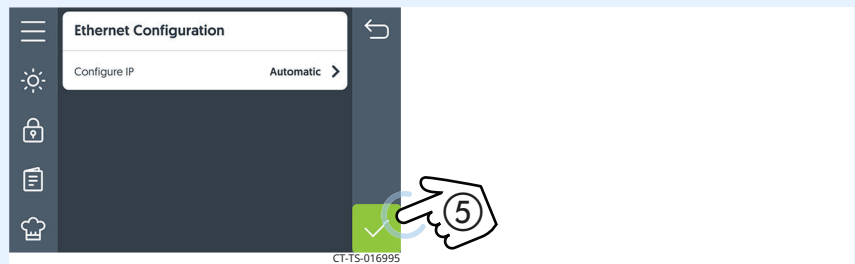

Continued on next page

Continued from previous page

### Manual IP configuration

- For manual IP configuration, **touch** the “Configure IP” setting ⑥. **Touch** “Manual” ⑦ and follow the prompts.

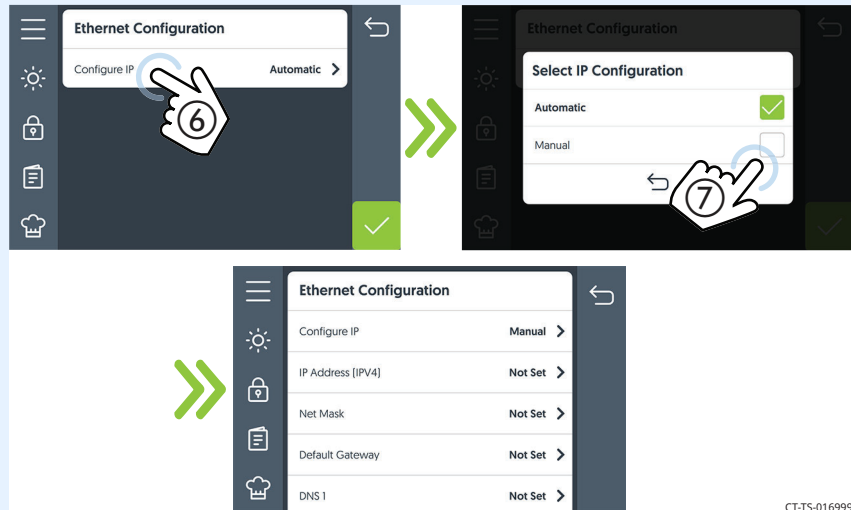

- Touch** the check mark when finished.

**NOTE:** If there are connection problems, touch the “ChefLinc” setting to address ChefLinc connectivity. For server connection issues, touch the “Update Server” setting.

### Result

The Ethernet connection is now set up.

This page is intentionally left blank.

# How to Turn On and Turn Off the Oven

## Before you begin

The oven must be connected to electric power.

## Turning on the oven

To turn on the oven, do the following.

| Step | Action   |  |
|------|--|--|
| 1.   | <p><b>Set</b> the main disconnect switch ① to the ON position.</p> <p><b>Touch</b> the ON/OFF button ②.</p> <div data-bbox="597 619 1339 724" style="border: 1px solid black; padding: 5px; margin: 10px 0;"> <p><b>i NOTE:</b> The main disconnect switch is meant to be used during service operations. For every day operation, it may be left in the ON position.</p> </div> <div data-bbox="544 745 1388 1081" style="display: flex; justify-content: space-around;">   </div> <p style="text-align: right; font-size: small;">VMC-TS-006253</p> |  |
|      | <p>2.</p>  | <p><b>Touch</b> and hold the ON/OFF button ② until the “Shut Down Options” screen displays. <b>Touch</b> “Shut down” ③. The oven activates the blowers for the cool-down process. The cool-down process is complete when the oven deactivates the blowers and the display screen turns off.</p> <div data-bbox="544 1417 1388 1753" style="display: flex; justify-content: space-around;">  </div> <p style="text-align: right; font-size: small;">VMC-UI-010613</p> |

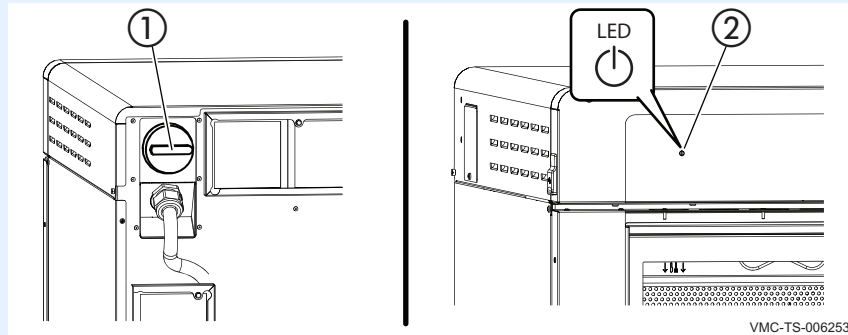

The oven is now on.

## Turning off the oven

To turn off the oven, do the following.

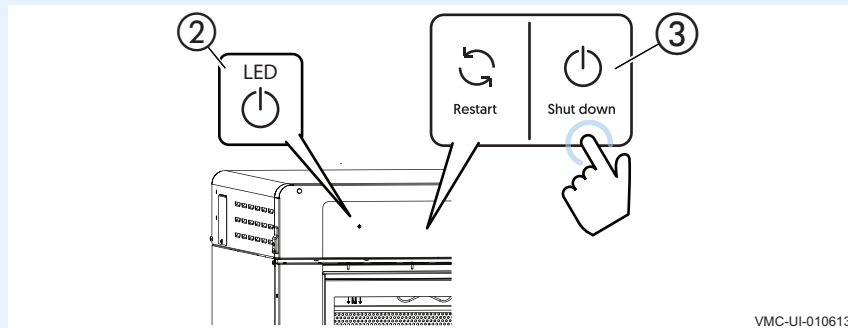

The oven is now off.

# How to Preheat the Oven

## Before you begin

### Make sure:

- The oven is turned on.
- The oven door is closed.

## Procedure

To preheat the oven, do the following.

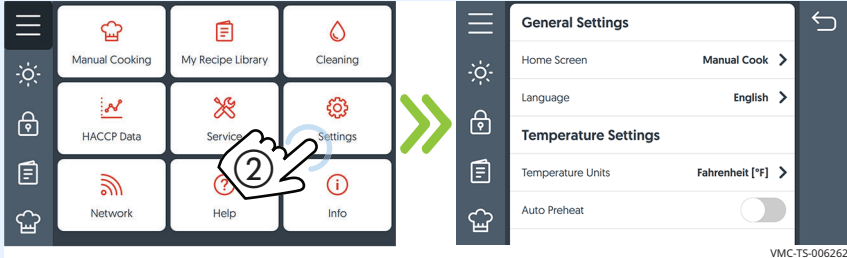
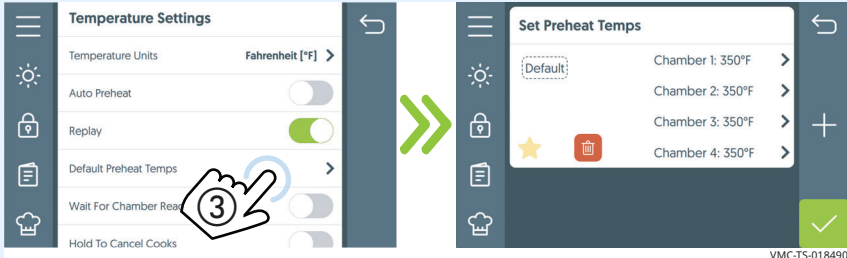
| Step | Action  |
|------|---|
| 1.   | <p><b>Touch</b> the menu icon ①. The menu screen displays.</p>  <p style="text-align: right; font-size: small;">VMC-TS-006259</p>   |
| 2.   | <p><b>Touch</b> the "Settings" icon ②. The "General Settings" screen displays.</p>  <p style="text-align: right; font-size: small;">VMC-TS-006262</p>  |
| 3.   | <p><b>Scroll</b> to the "Temperature Settings."</p> <p><b>Touch</b> the "Default Preheat Temps" icon ③. The "Set Preheat Temps" screen displays.</p>  <p style="text-align: right; font-size: small;">VMC-TS-018490</p> |

*Continued on next page*

Continued from previous page

4. **Touch** the preheat chamber setting for the chamber to be used ④. **Enter** the preheat temperature using the number pad. **Touch** the check mark. **Repeat** with remaining chambers



5. **Touch** the check mark ⑤. **Touch** the check mark ⑥ to return to the menu screen.

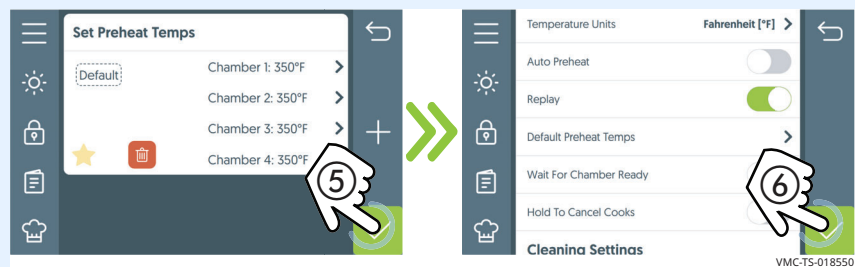

6. **Touch** the manual cook icon ⑦. The manual cook screen displays.



Continued on next page

Continued from previous page

7. **Touch** the preheat icon ⑧. The preheat confirmation screen displays.  
**Touch** "Preheat" ⑨. All chambers start to preheat to their preset temperatures.

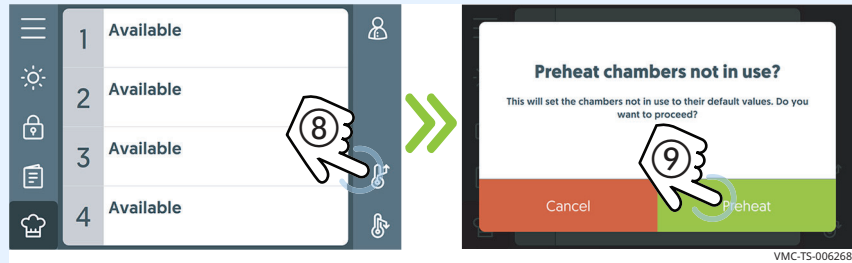

**Screen loading bars**

Loading bars indicate each chamber’s progress towards reaching its set temperature.

If necessary, touch the cancel icon ⑩ to cancel the preheating process before the individual chamber reaches its preset preheat temperature. Each chamber must be canceled individually.

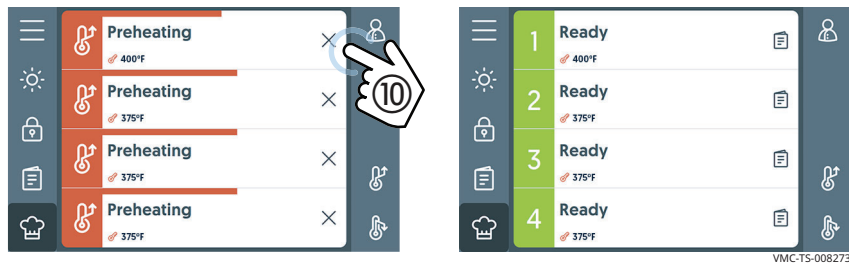

**Result**

The oven is preheating. When the preheat process is complete, the screen displays "Ready" for each chamber.

# How to Preheat the Oven with Multiple Preheat Setpoints

## Before you begin

### Make sure:

- The oven is turned on.
- The oven door is closed.

## Procedure

To preheat the oven with multiple preheat setpoints, do the following.

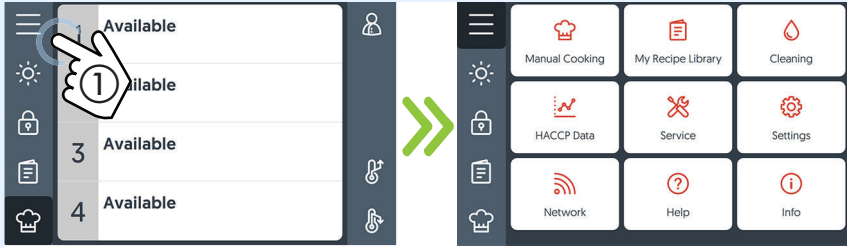
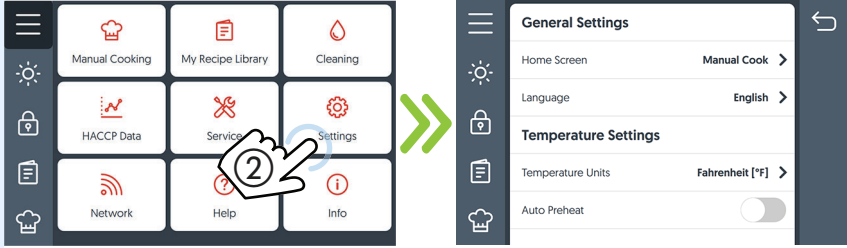
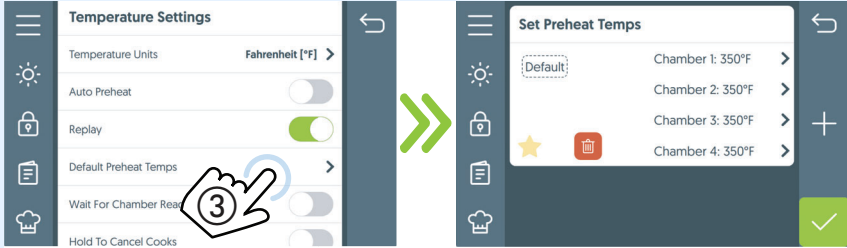
| Step | Action  |
|------|---|
| 1.   | <p><b>Touch</b> the menu icon ①. The menu screen displays.</p>  <p style="text-align: right;">VMC-TS-006259</p>   |
| 2.   | <p><b>Touch</b> the “Settings” icon ②. The “General Settings” screen displays.</p>  <p style="text-align: right;">VMC-TS-006262</p>   |
| 3.   | <p><b>Scroll</b> to the “Temperature Settings.”</p> <p><b>Touch</b> the “Default Preheat Temps” icon ③. The “Set Preheat Temps” screen displays.</p>  <p style="text-align: right;">VMC-TS-018490</p> |

*Continued on next page*

Continued from previous page

**Preset group 1**

4. **Touch** the preheat chamber setting for the chamber to be used **④**. **Enter** the preheat temperature using the number pad. **Touch** the check mark. **Repeat** for remaining chambers.



5. **Touch** the plus sign icon **⑤**. **Enter** a new name for the preset by using the keypad. **Touch** the check mark.



**Preset group 2**

6. **Touch** the preheat chamber setting for the chamber to be used **⑥**. **Enter** the preheat temperature using the number pad. **Touch** the check mark. **Repeat** for remaining chambers.

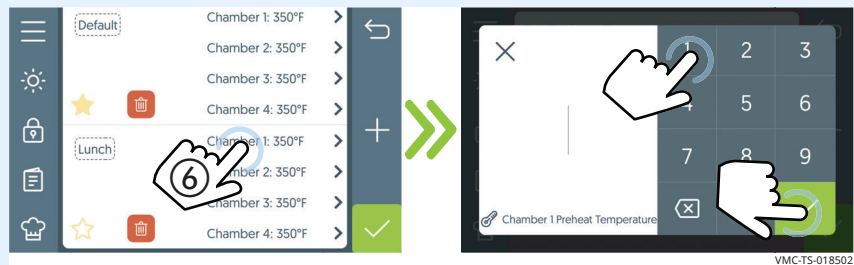

Continued on next page

Continued from previous page

7. **Touch** the “default” icon ⑦.

**Enter** a new name for the preset by using the keypad. **Touch** the check mark.

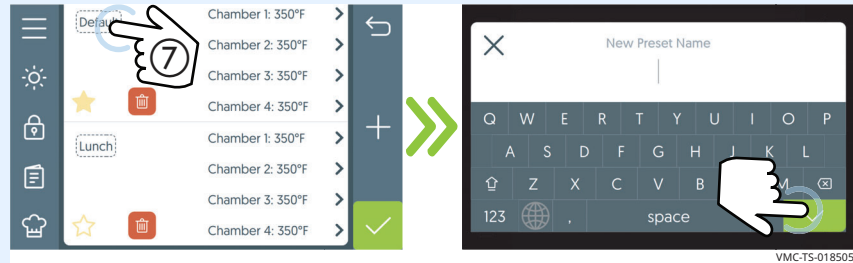

8. **Repeat** steps 5 and 6 if a third group of preheat presets is needed. A maximum of three preset groups can be used.

9. **Touch** the star icon ⑧ of the preset you want to set as the default for auto preheat.

**Touch** the check mark ⑨.

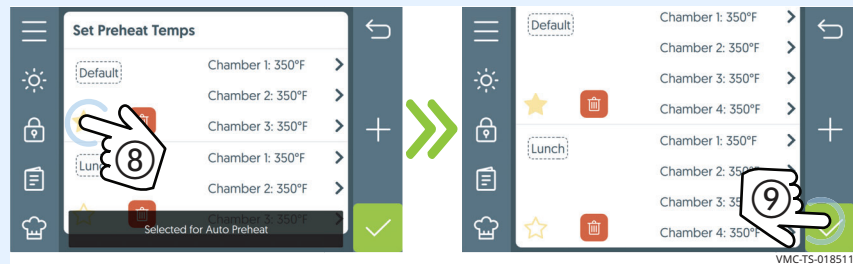

10. **Touch** the check mark ⑩.

**Touch** the manual cook icon ⑪ to return to the manual cook screen.



Continued on next page

Continued from previous page

11. **Touch** the preheat icon ⑫. The “Select Preheat Temperatures” screen displays.

**Touch** desired preheat setting ⑬. All chambers start to preheat to their preset temperatures.

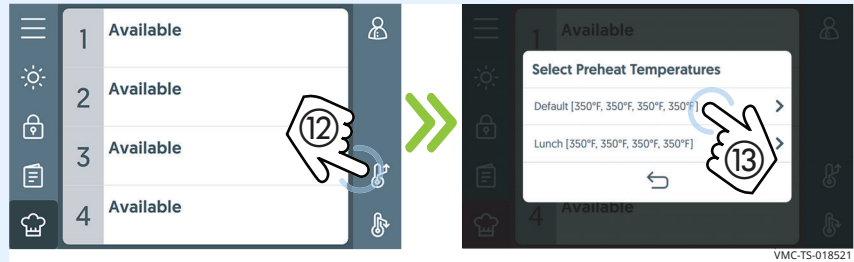

**Screen loading bars**

Loading bars indicate each chamber’s progress towards reaching its set temperature.

If necessary, touch the cancel icon ⑭ to cancel the preheating process before the individual chamber reaches its preset preheat temperature. Each chamber must be canceled individually.

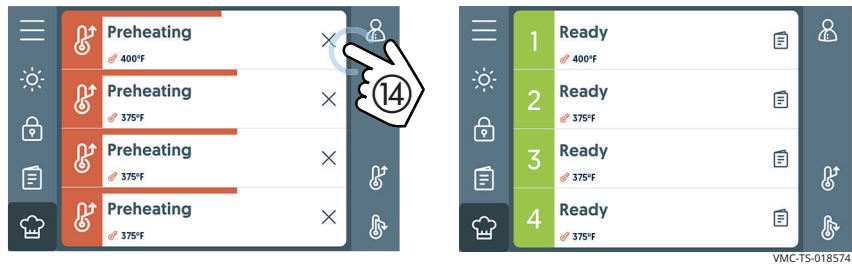

**Result**

The oven is preheating. When the preheat process is complete, the screen displays “Ready” for each chamber.

# How to Cook with Programmed Recipes

## Before you begin

### Make sure:

- The oven is preheated.
- Your food is prepared and ready to cook.

## Procedure

To cook using a programmed recipe, do the following.

| Step | Action  |
|------|---|
| 1.   | <p><b>Touch</b> the recipe book icon ① for the desired chamber to cook in. The “Chamber 1: recipes in range” screen displays.</p>  |
| 2.   | <p><b>Navigate</b> to the recipe. <b>Touch</b> the recipe ②.</p>   |
| 3.   | <p><b>Open</b> the door and load the food into the chamber.<br/><b>Close</b> the door.</p>  |









*Continued on next page*

Continued from previous page

## During the cooking process

The cooking status screen displays the details on the current cook setting.

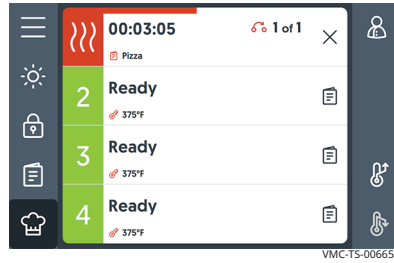

During the cooking process:

| Action   | Result                                   |
|--|--|
| Touch the hand icon  when action is required... | to continue the cooking process.         |
| Touch the chamber...   | to show the recipe details.              |
| Touch and hold the chamber number...   | to show the current chamber temperature. |
| Touch "X"...   | to cancel the cooking process.           |

## Result

At the end of the cooking process, the oven sounds an alert, and the chamber light flashes. Remove the cooked food.

**NOTE:** Be sure to remove the cooked food after the cooking process is complete. The oven will revert back to the preheat temperature. If left inside the oven, the food will continue to cook.

# How to Cook in Manual Mode

## Before you begin

### Make sure:

- The oven is preheated.
- Your food is prepared and ready to cook.

## Background

This procedure consists of:

- setting the food loading action;
- and setting the cooking stage parameters (temperature, time, and fan speed).

## Procedure

To cook in manual mode, do the following.

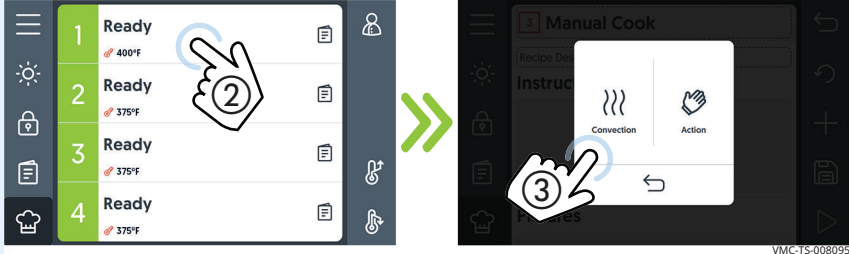
| Step | Action  |
|------|---|
| 1.   | <p><b>Touch</b> the manual cook icon ①. The available chambers are displayed.</p>  <p style="text-align: right; font-size: small;">VMC-TS-008092</p>                                     |
| 2.   | <p><b>Touch</b> any available chamber ②.</p> <p><b>Touch</b> "Convection" or "Action" ③ to choose the step type.</p>  <p style="text-align: right; font-size: small;">VMC-TS-008095</p> |
|      | <p><b>NOTE:</b> Touching "Action" adds an action step to the recipe. An action adds manual tasks to be completed during the recipe such as loading the food or adding an ingredient.</p>  |

*Continued on next page*

Continued from previous page

- The “Manual Cook” screen displays. The upcoming steps set the parameters for this screen.



- Touch** the cooking time (4). **Enter** the cooking time using the key pad. **Touch** the check mark.

**Touch** the cooking temperature icon (5). **Enter** the cooking temperature using the key pad. **Touch** the check mark.

**Touch** the fan speed icon (6). **Enter** the fan speed using the key pad. The fan speed can be set in increments of five percent. **Touch** the check mark.

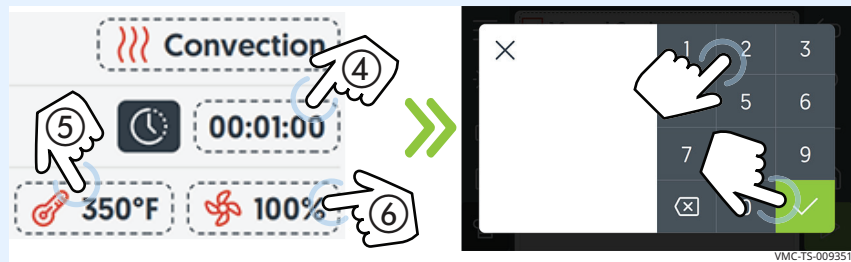

- Touch** the plus (+) icon (7) to add an additional step or action, if needed.

- Load** the food into the appropriate chamber.

- Touch** the start icon (8). The cooking process timer starts to count down.



Continued on next page

Continued from previous page

## During the cooking process

| Action   | Result                                   |
|--|--|
| Touch the hand icon  when action is required... | to continue the cooking process.         |
| Touch the chamber...   | to show the recipe details.              |
| Touch and hold the chamber number...   | to show the current chamber temperature. |
| Touch "X"...   | to cancel the cooking process.           |

8. At the end of the cooking process, the oven sounds an alert, and the chamber light flashes.

9. **Open** the door and remove the hot food.



**NOTE:** Be sure to remove the cooked food after the cooking process is complete. The oven will revert back to the preheat temperature. If left inside the oven, the food will continue to cook.

## Result

The food is now cooked.

# How to Cook in Professional Mode

## Before you begin

### Make sure:

- The oven is preheated.
- Your food is prepared and ready to cook.

## Background

This procedure consists of:

- setting the food loading action;
- and setting the cooking stage parameters (temperature, time, and fan speed).

## Procedure

To cook in professional mode, do the following.

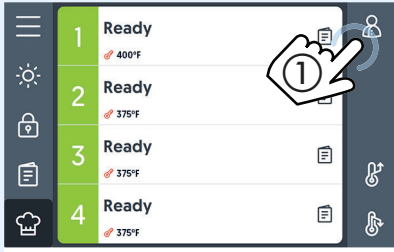
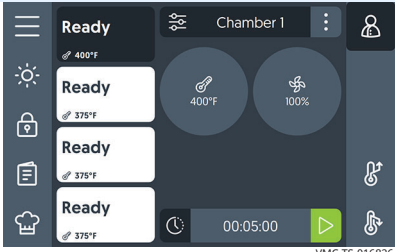
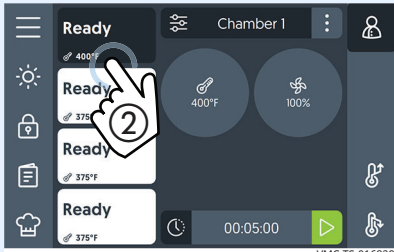
| Step | Action  |
|------|---|
| 1.   | From the manual cooking screen, <b>touch</b> the professional cook icon ①. The available chambers are displayed.  |
|      |   |
| 2.   | <b>Touch</b> any available chamber ②.   |
|      |    |

*Continued on next page*

Continued from previous page

**Cooking by time**

3. **Touch** the cooking time (3). **Enter** the cooking time using the key pad. **Touch** the check mark.

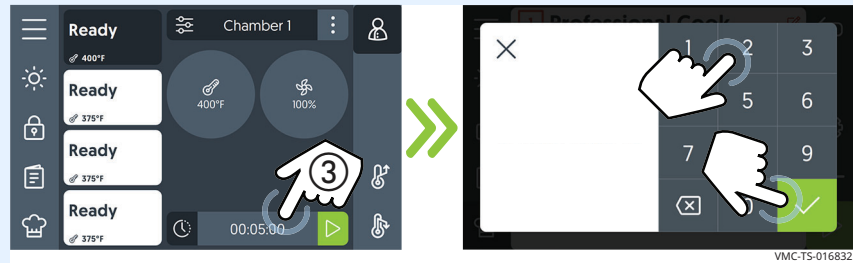
**Continuous cooking**

4. To set an indefinite cooking timer, **touch** the continuous cook icon (4). **Touch** the check mark.



5. **Touch** the cooking temperature (5). **Enter** the cooking temperature using the key pad. **Touch** the check mark.  
**Touch** the fan speed (6). **Enter** the fan speed using the key pad. **Touch** the check mark.

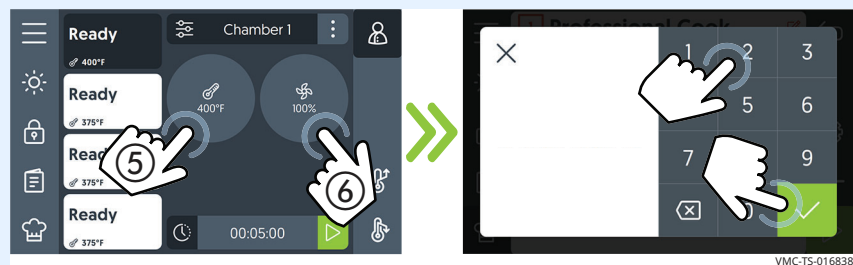

6. **Load** the food into the appropriate chamber.

Continued on next page

Continued from previous page

7. **Touch** the start icon ⑦. The cooking stage timer starts to count down.

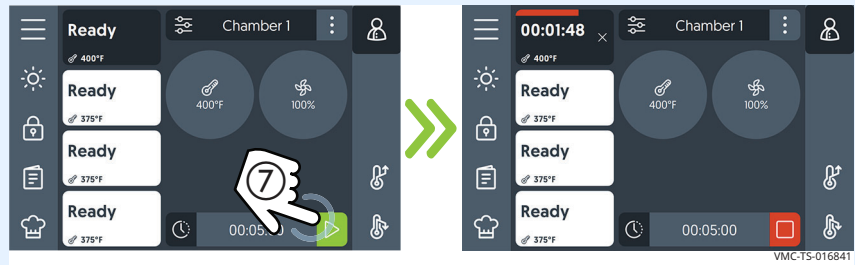

**During the cooking process**

| Action       | Result                         |
|--------------|--------------------------------|
| Touch "X"... | to cancel the cooking process. |

8. At the end of the cooking process, the oven sounds an alert, and the chamber light flashes.

9. **Open** the door and remove the hot food.

**NOTE:** Be sure to remove the cooked food after the cooking process is complete. The oven will revert back to the preheat temperature. If left inside the oven, the food will continue to cook.

**Result**

The food is now cooked.

# How to Use the Dual Timers

## Before you begin

### Make sure:

- The oven is preheated.
- Your food is prepared and ready to cook.

## Background

There may be times when you will want to use the same chamber to cook two pans of food at the same time, but at different intervals. The dual timer function allows you to do so.

## Procedure

To cook using the dual timers, do the following.

| Step | Action |
|------|--------|
|------|--------|

1. From the manual cooking screen, **touch** the professional cook icon ①. The available chambers are displayed.

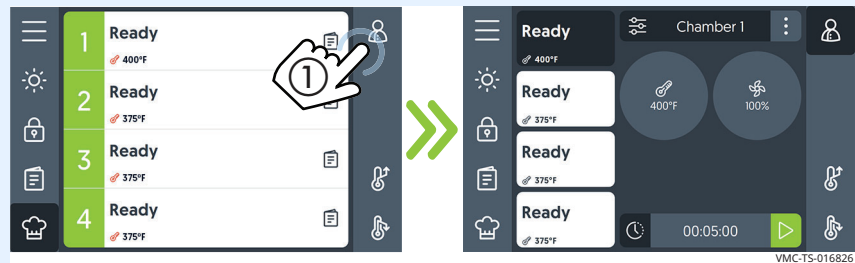

2. **Touch** any available chamber ②.

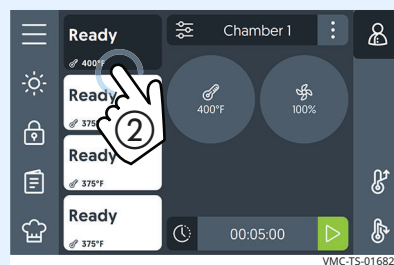

*Continued on next page*

Continued from previous page

3. **Touch** the chamber options icon (3). Then, **touch** the chamber multiple shelf icon (4).



4. **Touch** the cooking time (5) for pan 1. **Enter** the cooking time using the key pad. **Touch** the check mark.

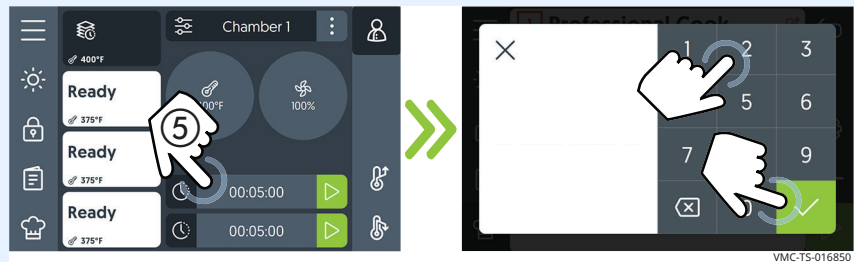

5. **Touch** the cooking time (6) for pan 2. **Enter** the cooking time using the key pad. **Touch** the check mark.

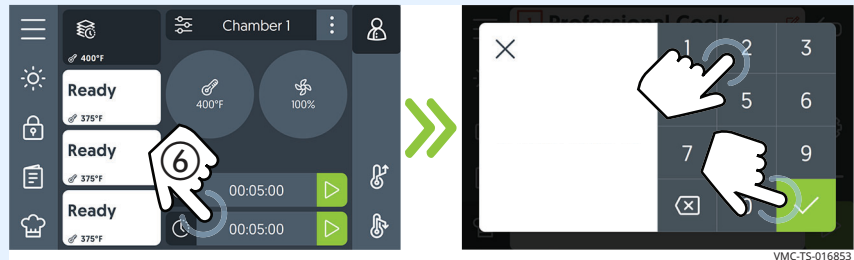

6. **Touch** the cooking temperature (7). **Enter** the cooking temperature using the key pad. **Touch** the check mark.

**Touch** the fan speed (8). **Enter** the fan speed using the key pad. **Touch** the check mark.

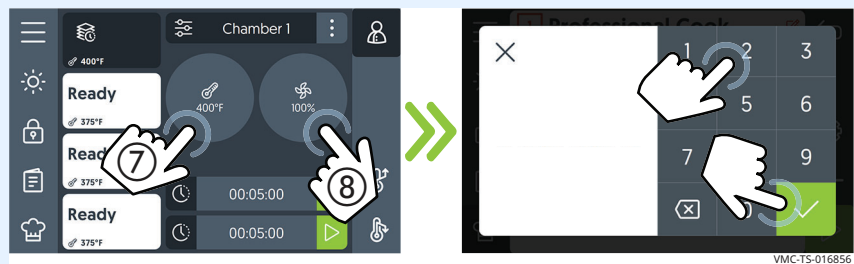

Continued on next page

Continued from previous page

7. **Load** pan 1 into the appropriate chamber.

**Touch** the start icon ⑨.

The cooking stage timer starts to count down for pan 1.



8. **Load** pan 2 into the appropriate chamber.

**Touch** the start icon ⑩.

The cooking stage timer starts to count down for pan 2.



At the end of the cooking process, the oven sounds an alert, and the chamber light flashes.

9. **Open** the door and remove the hot food.

**NOTE:** Be sure to remove the cooked food after the cooking process is complete. The oven will revert back to the preheat temperature. If left inside the oven, the food will continue to cook.

## Result

The food is now cooked.

# How to Lock and Unlock the Screen

## Before you begin

The oven is turned on.

## Background

The screen can be locked to prevent changes being made during the cooking process.

## Procedure

To lock and unlock the screen, do the following.

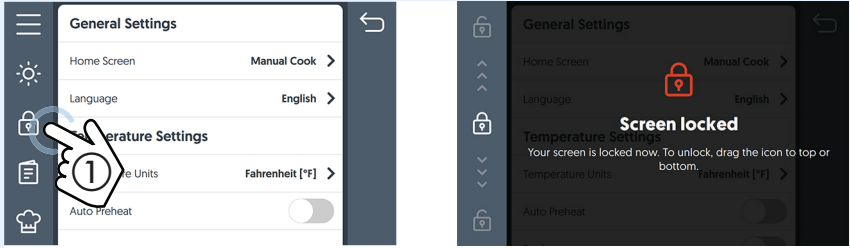
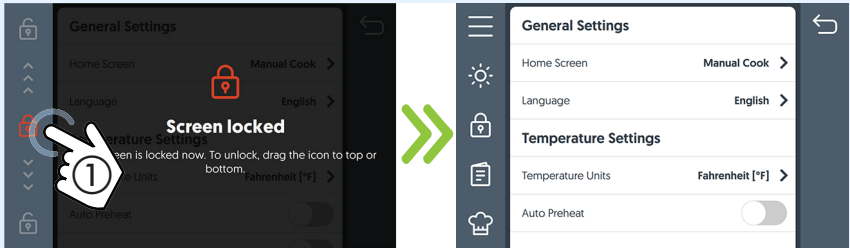
| Step | Action  |
|------|---|
| 1.   | <p><b>Touch</b> the lock icon ①. The screen is now locked.</p>  <p style="text-align: right; font-size: small;">VMC-TS-012874</p>   |
| 2.   | <p>To unlock the screen, <b>touch and hold</b> the lock icon ① and drag it to the top or bottom of the screen.</p>  <p style="text-align: right; font-size: small;">VMC-TS-012947</p> |

## Result

The screen is now locked or unlocked.

# How to Cool Down the Oven

## Procedure

To cool down the oven, do the following.

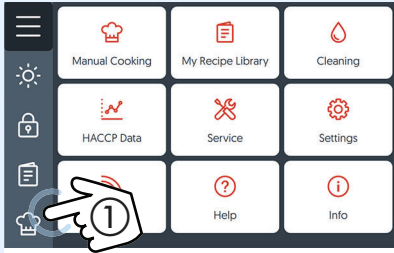
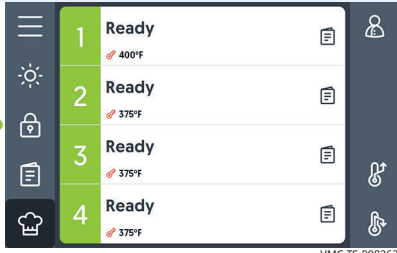
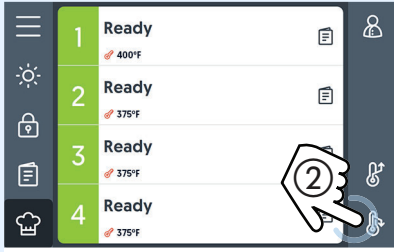
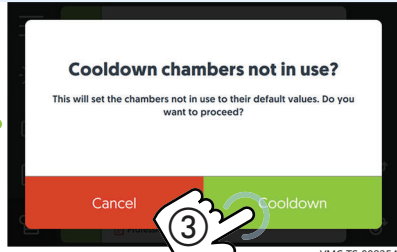
| Step | Action  |
|------|---|
| 1.   | <p><b>Touch</b> the manual cook icon ①.</p>     |
| 2.   | <p><b>Touch</b> the cool down icon ②. The cool down confirmation screen displays.</p> <p><b>Touch</b> "Cooldown" ③. <b>Open</b> the door.</p> <div style="border: 1px solid gray; padding: 5px; margin: 10px 0;"> <p><b>NOTE:</b> The oven activates the blowers for the cool down process. The oven deactivates the blowers when the cool down process is complete.</p> </div>   |

## Cooling down progress bars

Progress bars indicate each chamber's progress towards reaching its cool down temperature.

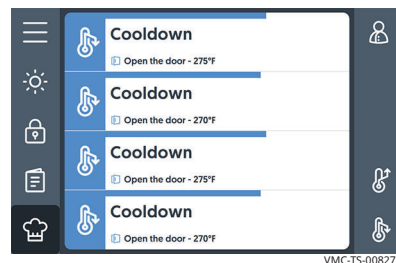

## Result

The oven is now cooled down.

# How to Create a Recipe

## Background

Creating a recipe consists of:

- Setting the cooking stage(s) parameters (temperature, time, and fan speed);
- setting an action step if desired such as adding an ingredient;
- naming the recipe;
- adding a description to the recipe;
- adding a photo to the recipe;
- and adding the recipe to a category.

## Procedure

To create a recipe, do the following.

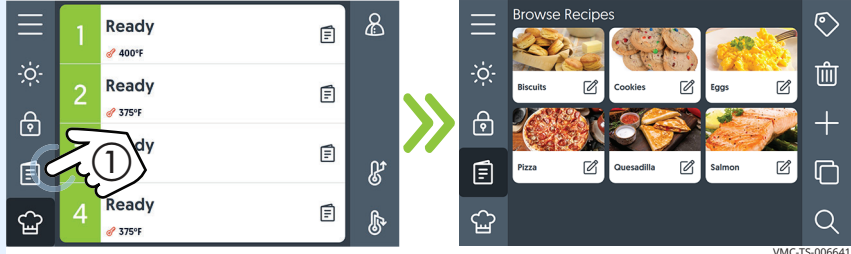
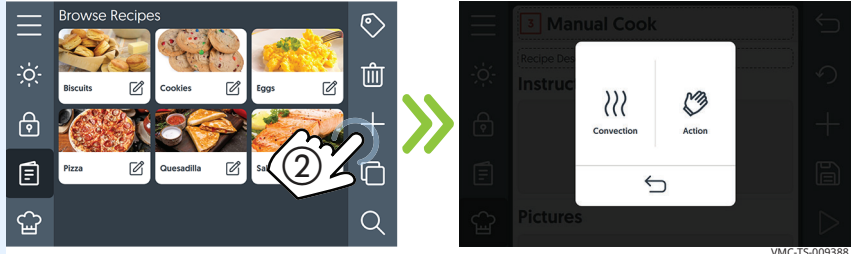
| Step | Action  |
|------|---|
| 1.   | <p><b>Touch</b> the recipe book icon ①. The “Browse Recipes” screen displays.</p>  <p>The first screenshot shows a vertical list of recipe cards with a hand icon pointing to the first card, labeled with a circled '1'. The second screenshot shows the 'Browse Recipes' screen with a grid of recipe thumbnails (Biscuits, Cookies, Eggs, Pizza, Quesadilla, Salmon) and a hand icon pointing to the plus icon in the bottom right corner, labeled with a circled '2'. A green double arrow points from the first screenshot to the second.</p> <p style="text-align: right; font-size: small;">VMC-TS-006641</p> |
| 2.   | <p><b>Touch</b> the plus icon ②. The step type screen displays.</p>  <p>The first screenshot shows the 'Browse Recipes' screen with a hand icon pointing to the plus icon in the bottom right corner, labeled with a circled '2'. The second screenshot shows the 'Manual Cook' step type screen with options for 'Convection' and 'Action', and a hand icon pointing to the 'Action' option. A green double arrow points from the first screenshot to the second.</p> <p style="text-align: right; font-size: small;">VMC-TS-009388</p>  |

*Continued on next page*

Continued from previous page

3. **Touch** "Convection" or "Action" ③ to choose the step type.

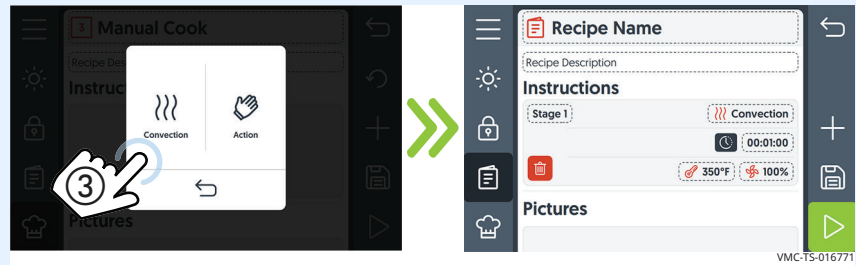

**NOTE:** Touching "Action" adds an action step to the recipe. An action adds manual tasks to be completed during the recipe such as loading the food or adding an ingredient.

4. **Touch** "Recipe Name" ④. The "Recipe name" screen displays.



5. **Enter** the recipe name. **Touch** the check mark ⑤ to return to the create recipe screen.

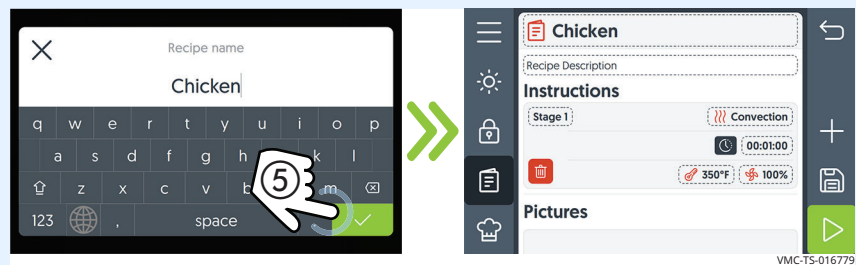

Continued on next page

Continued from previous page

6. **Touch** "Recipe Description" ⑥. The recipe description screen displays. **Enter** the recipe description. **Touch** the check mark to return to the create recipe screen.

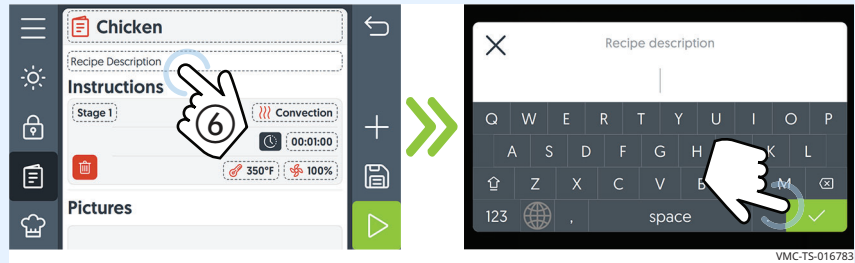

7. **Touch** the cooking time ⑦. **Enter** the cooking time using the key pad. **Touch** the check mark.



8. **Touch** the chamber temperature set-point icon ⑧. **Enter** the chamber temperature set-point using the key pad. **Touch** the check mark.



9. **Touch** the fan speed icon ⑨ to set the fan speed. **Enter** the fan speed using the key pad. **Touch** the check mark.



Continued on next page

Continued from previous page

10. **Touch** the plus icon (10) to add an additional stage or action.  
**Touch** the delete icon (11) to delete a stage or action.



11. **Scroll** to "Pictures" to add a photo to the recipe.  
 12. **Scroll** to "Categories" to add the recipe to a category.  
 13. **Touch** the save icon (12) when finished to save the recipe.

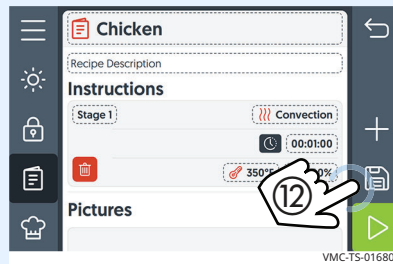

## Result

A new recipe has been created.

# How to Modify, Duplicate, or Delete a Recipe

## Procedure

To modify, duplicate, or delete a recipe, do the following.

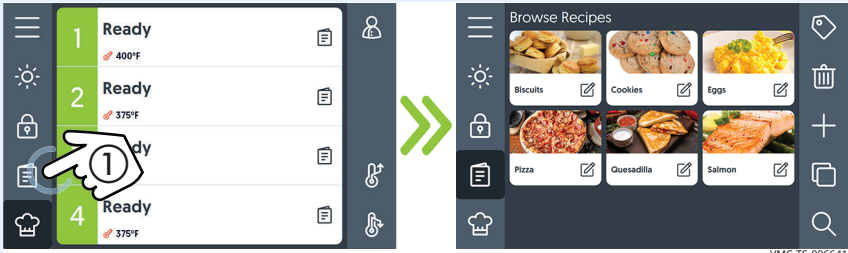
| Step | Action   |
|------|--|
| 1.   | <p><b>Touch</b> the recipe book icon ①. The “Browse Recipes” screen displays.</p>  |

## Modifying

2. To modify a recipe, **touch** the recipe edit icon ② of the desired recipe.



The first stage of the recipe displays. There will be a screen for each stage. Scroll to the stage you want to modify.

- **Touch** the cook by time or cook by probe icon then modify the value using the key pad.
- **Touch** the chamber set-point icon to modify the chamber temperature.
- **Touch** the fan speed icon to modify the fan speed.

**Touch** the save icon ③ when finished.

**Touch** the trash icon ④ to delete the stage, if desired.

*Continued on next page*

Continued from previous page

## Duplicating

3. To duplicate a recipe, **touch** the duplicate recipe icon ⑤ of the desired recipe.

**Touch** the recipe to copy it. The recipe copy will display next to the selected recipe. Edit the copied recipe as desired.

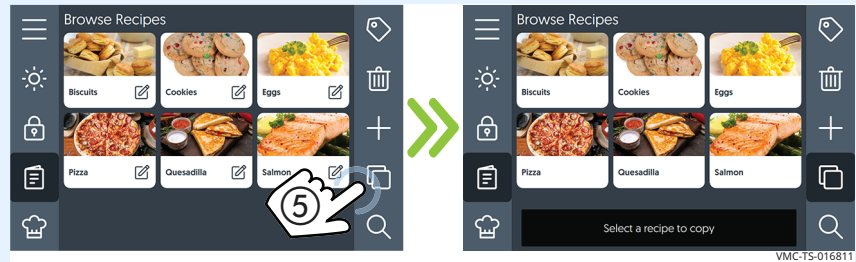

## Deleting

4. To delete a recipe, **touch** the delete icon ⑥.

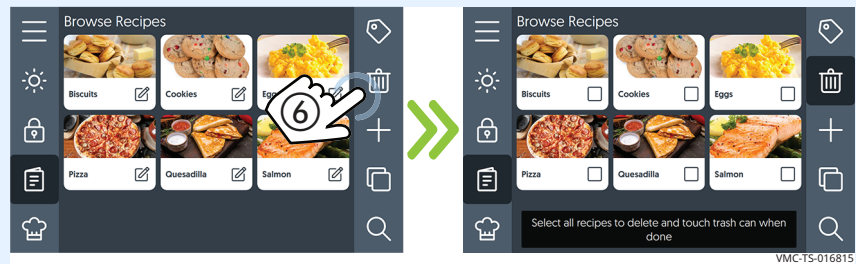

**Select** the recipe(s) that you want to delete. **Touch** the delete icon ⑥ again.

**Touch** "Continue" ⑦ to confirm that you want to delete the recipe(s).

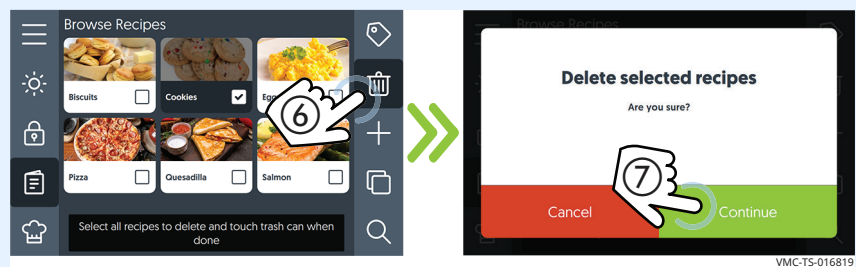

## Result

The procedure is now complete.

# How to Create a Category

## Background

A category allows the user to label and group recipes together. When viewing a recipe, the user can add a recipe to a category by touching the check mark next to the desired category. The categories can be viewed at the bottom of an existing recipe screen.

A recipe can be assigned to multiple categories.

## Procedure

To create a category, do the following.

| Step | Action   |
|------|--|
| 1.   | <p><b>Touch</b> the recipe book icon ①. The “Browse Recipes” screen displays.</p>   <p style="text-align: right; font-size: small;">VMC-TS-006641</p>                  |
| 2.   | <p><b>Touch</b> the categories icon ②. The “Browse Categories” screen displays.</p>   <p style="text-align: right; font-size: small;">CT-TS-016752</p>             |
| 3.   | <p><b>Touch</b> the plus icon ③ to add a category. The “Create a Category” screen displays.</p>   <p style="text-align: right; font-size: small;">CT-TS-016755</p> |

*Continued on next page*

Continued from previous page

4. **Enter** the category name. **Touch** the check mark ④. The category has been created.

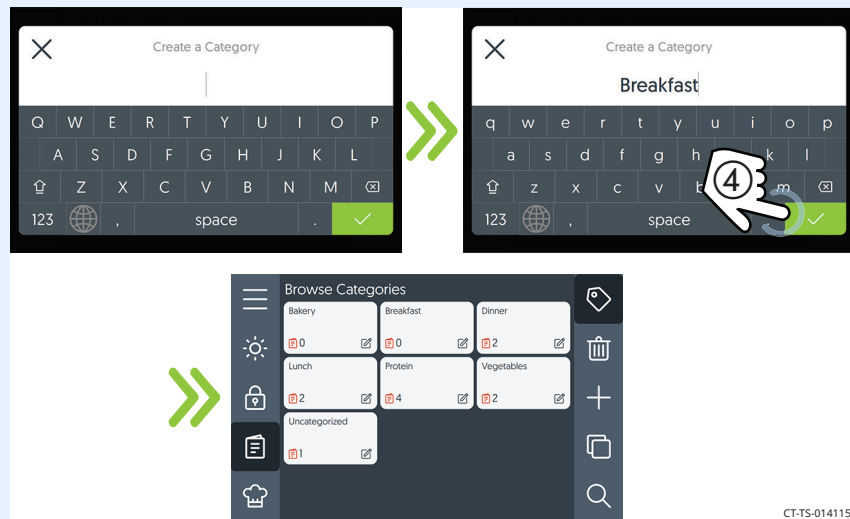

## Duplicating

5. To duplicate a category, **touch** the duplicate category icon ⑤ of the desired category.
- Touch** the category to copy it. The category copy will display next to the selected category.



Continued on next page

Continued from previous page

## Deleting

6. To delete a category, **touch** the delete icon ⑥.

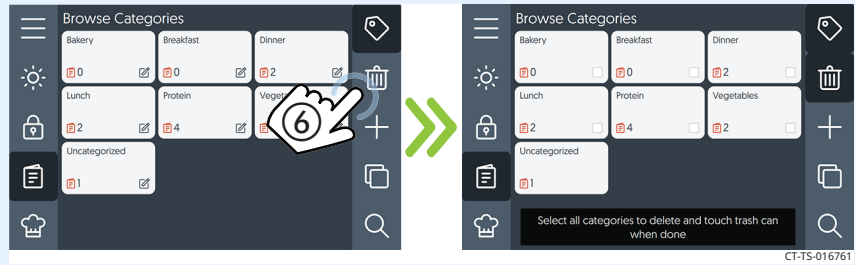

**Select** the category that you want to delete. **Touch** the delete icon ⑥ again.

**Touch** "Delete" ⑦ to confirm that you want to delete the category.



## Result

The procedure is now complete.

# How to Backup or Restore Settings with a USB Drive

## Before you begin

You will need a USB drive.

## Procedure

To backup or restore settings with a USB drive, do the following.

| Step | Action   |
|------|--|
| 1.   | Touch the menu icon ①. The menu screen displays.                     |
| 2.   | Touch the "Settings" icon ②. The "General Settings" screen displays. |
| 3.   | Plug the USB drive ③ into the port.                                  |

1. Touch the menu icon ①. The menu screen displays.

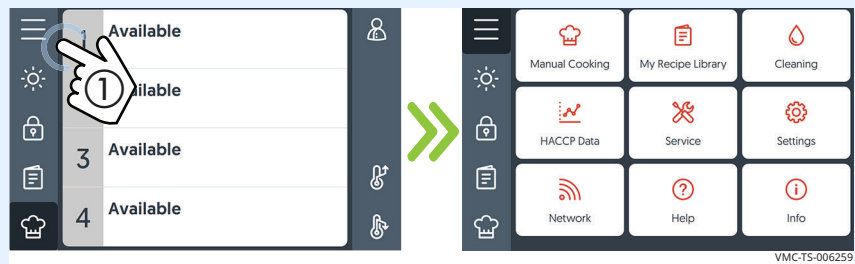

2. Touch the "Settings" icon ②. The "General Settings" screen displays.

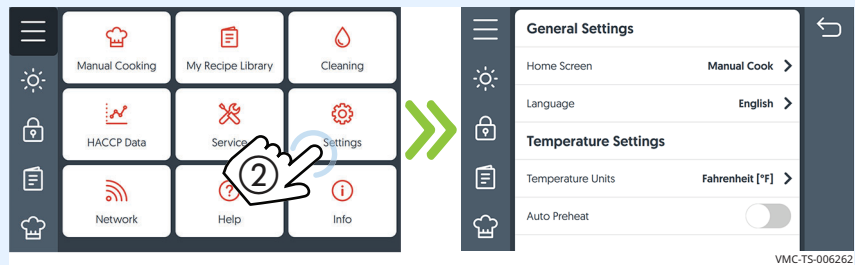

3. Plug the USB drive ③ into the port.

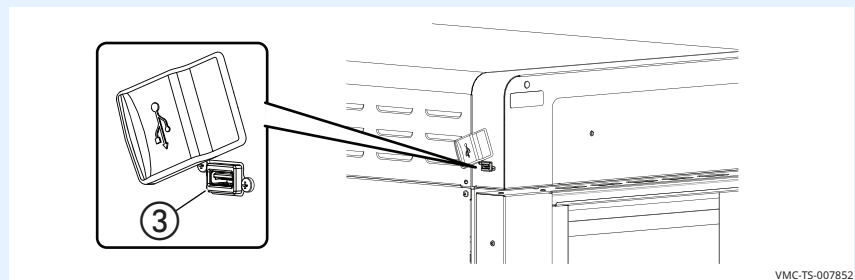

*Continued on next page*

Continued from previous page

4. **Scroll** to “System Backup & Update.”

**Touch** “Backup Settings to USB” or “Restore Settings from USB” ④. The USB screen displays.



5. **Select** the settings file ⑤.

**Touch** the check mark ⑥.

**NOTE:** Subfolders can be set up on the USB drive from your computer. To import settings from a subfolder, touch a subfolder, select the settings file, then touch the check mark.



**Loading the recipes**

The oven downloads or restores the settings. When the process is complete, **touch** the check mark ⑦ to return to the general settings screen. **Remove** the USB drive.

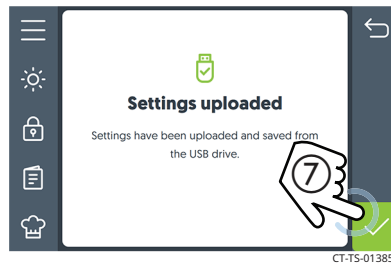

**Result**

The settings have now been saved to the USB drive or restored from the USB drive.

# How to Backup Recipes to a USB Drive

## Before you begin

You will need a USB drive.

## Procedure

To backup recipes from the oven to a USB drive, do the following.

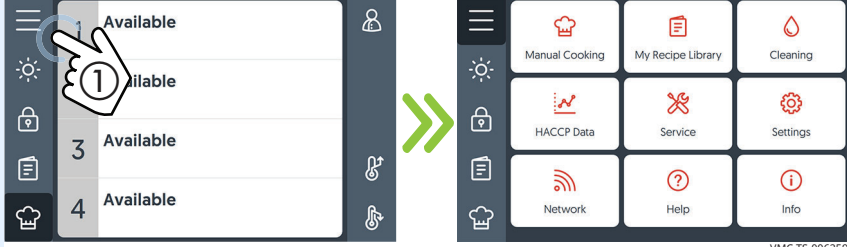
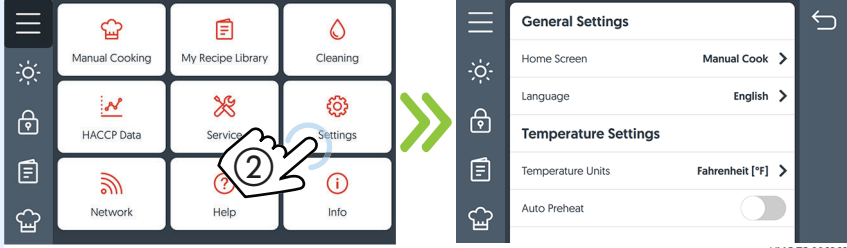
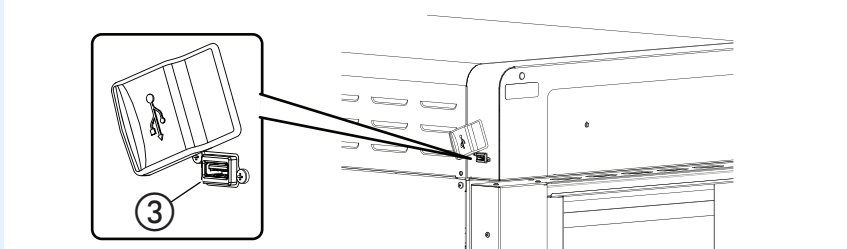
| Step | Action  |
|------|---|
| 1.   | <p><b>Touch</b> the menu icon ①. The menu screen displays.</p>  <p style="text-align: right;"><small>VMC-TS-006259</small></p>                      |
| 2.   | <p><b>Touch</b> the “Settings” icon ②. The “General Settings” screen displays.</p>  <p style="text-align: right;"><small>VMC-TS-006262</small></p> |
| 3.   | <p><b>Plug</b> the USB drive ③ into the port.</p>  <p style="text-align: right;"><small>VMC-TS-007852</small></p>                                 |

*Continued on next page*

Continued from previous page

4. **Scroll** to “System Backup & Update.”

**Touch** the “Backup Recipes to USB” ④ setting. The USB screen displays.

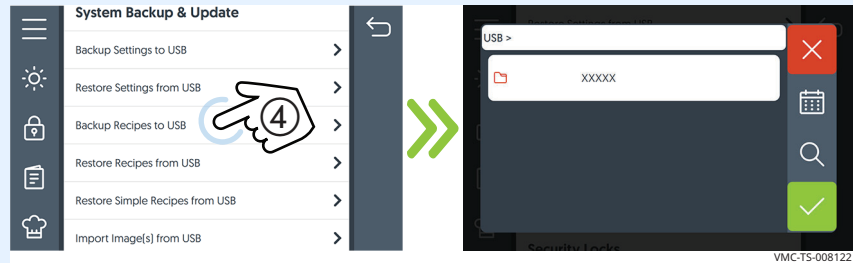

5. **Touch** the check mark ⑤ to save the recipes to the top level of the USB drive.

**NOTE:** Subfolders can be set up on the USB drive from your computer. To save a file to a subfolder, touch a subfolder then touch the check mark.



**Loading the recipes**

The oven downloads the recipes onto the USB drive. When the process is complete, the “Download successful” screen displays. **Touch** the check mark ⑥ to return to the general settings screen. **Remove** the USB drive.

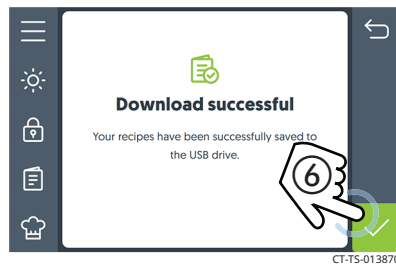

**Result**

The recipes are now saved to the USB drive.

# How to Restore Recipes from a USB Drive

## Before you begin

You will need a USB drive loaded with recipes.

## Procedure

To restore recipes from the USB drive to the oven, do the following.

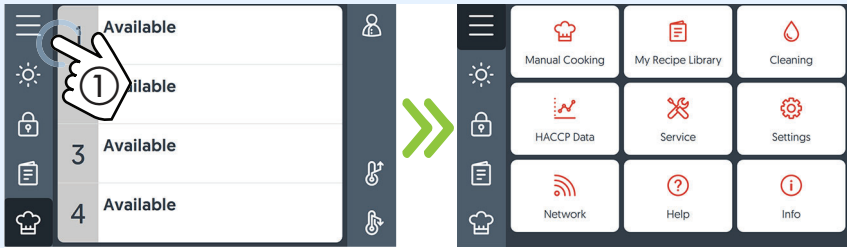
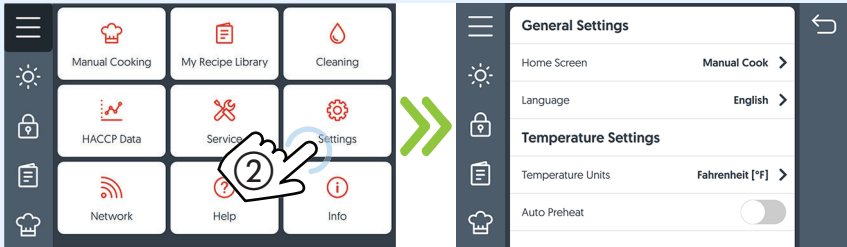
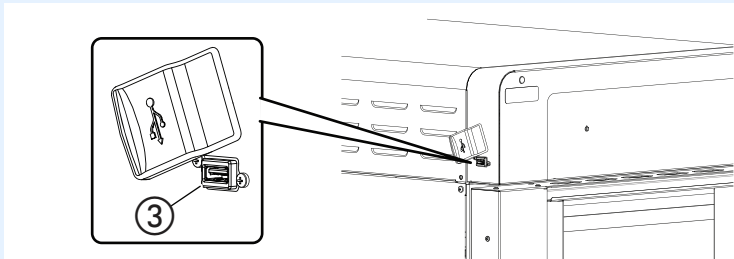
| Step | Action   |
|------|--|
| 1.   | <p><b>Touch</b> the menu icon ①. The menu screen displays.</p>  <p style="text-align: right;">VMC-TS-006259</p>                      |
| 2.   | <p><b>Touch</b> the “Settings” icon ②. The “General Settings” screen displays.</p>  <p style="text-align: right;">VMC-TS-006262</p> |
| 3.   | <p><b>Plug</b> the USB drive ③ into the port.</p>  <p style="text-align: right;">VMC-TS-007852</p>                                 |

*Continued on next page*

Continued from previous page

4. **Scroll** to “System Backup & Update.”

**Touch** the “Restore Recipes from USB” ④ setting. The USB screen displays.

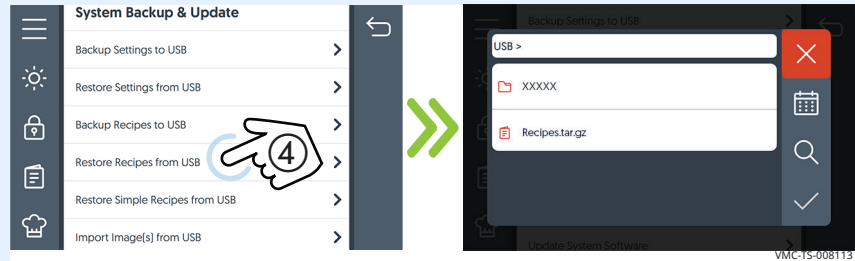

5. **Select** the recipe file ⑤. **Touch** the check mark ⑥ to load the recipes to the oven. **Select** “Overwrite” to overwrite existing recipe file or select “Keep” to keep existing recipes with the new recipe file.

**NOTE:** Subfolders can be set up on the USB drive from your computer. To load a file from a subfolder, touch a subfolder then touch the check mark.

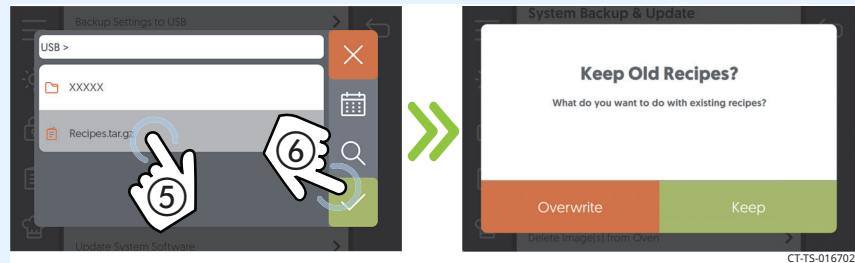

**Loading the recipes**

The oven loads the recipe file. When the process is complete, the “Recipes uploaded” screen displays. **Touch** the check mark ⑦ to return to the general settings screen. **Remove** the USB drive.



**Result**

The recipes are now restored.

# How to Import Images from a USB Drive

## Before you begin

You will need a USB drive loaded with the images.

## Procedure

To import images from the USB drive to the oven, do the following.

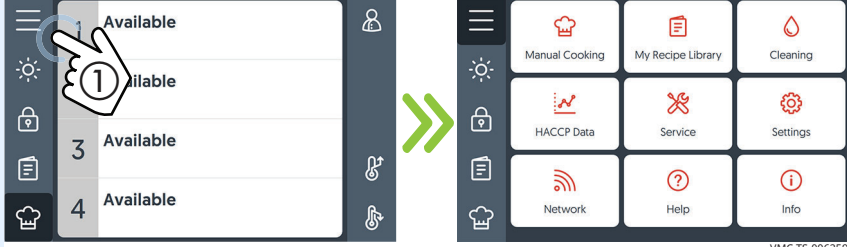
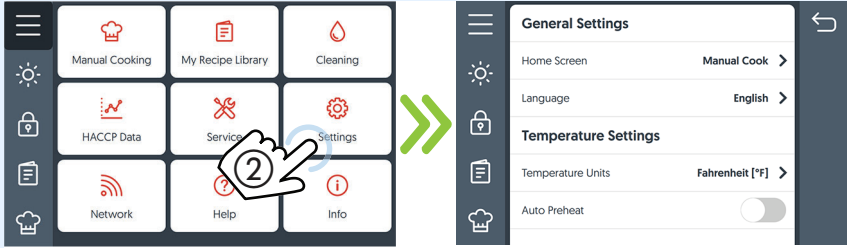
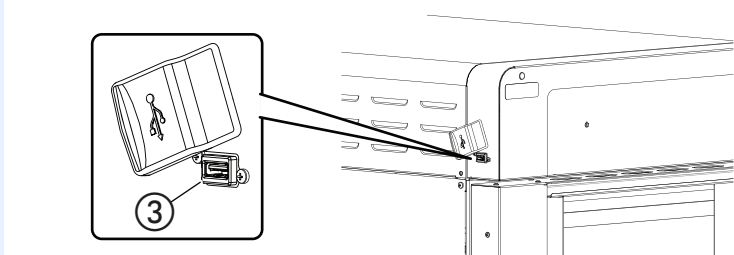
| Step | Action   |
|------|--|
| 1.   | <p><b>Touch</b> the menu icon ①. The menu screen displays.</p>  <p style="text-align: right;">VMC-TS-006259</p>                      |
| 2.   | <p><b>Touch</b> the “Settings” icon ②. The “General Settings” screen displays.</p>  <p style="text-align: right;">VMC-TS-006262</p> |
| 3.   | <p><b>Plug</b> the USB drive ③ into the port.</p>  <p style="text-align: right;">VMC-TS-007852</p>                                 |

*Continued on next page*

Continued from previous page

4. **Scroll** to “System Backup & Update.”

**Touch** the “Import Image(s) from USB” ④ setting. The USB screen displays.

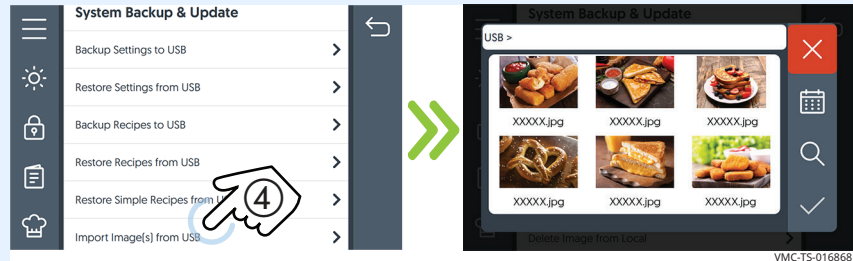

5. **Select** the images ⑤.

**Touch** the check mark ⑥.

**NOTE:** Subfolders can be set up on the USB drive from your computer. To import images from a subfolder, touch a subfolder, select the images, then touch the check mark.



**Loading the images**

The oven loads the selected images. When the process is complete, the “Images uploaded” screen displays. **Touch** the check mark ⑦ to return to the general settings screen. **Remove** the USB drive.

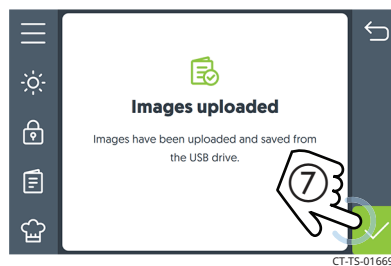

**Result**

The images are now imported.

# How to Update Software with a USB Drive

## Before you begin

### Make sure:

- The oven is on and cool to the touch (room temperature).
- You will need a USB drive with the updated software. To download the most up to date oven software and register for email notifications when new software versions are released, please visit <https://www.alto-shaam.com/en/customer-support/software-downloads>.
- Do not remove the USB drive during the update process.

## Procedure

To update the software, do the following.

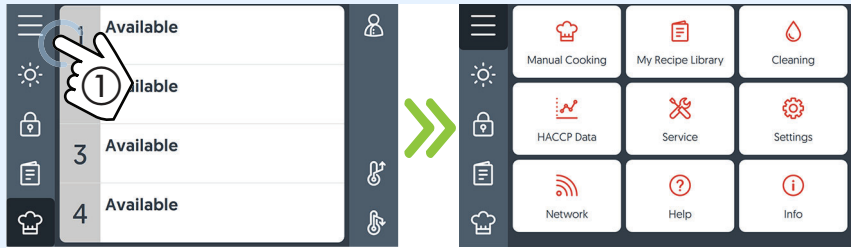
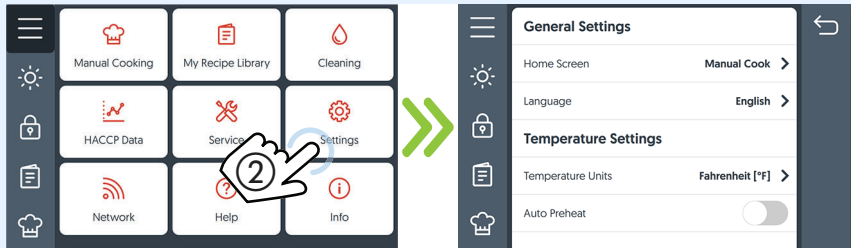
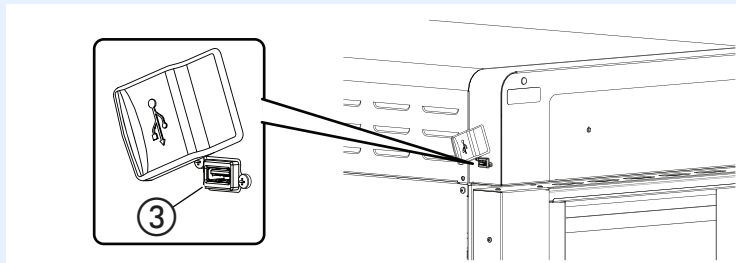
| Step | Action   |
|------|--|
| 1.   | <p><b>Touch</b> the menu icon ①. The menu screen displays.</p>  <p style="text-align: right;"><small>VMC-TS-006259</small></p>                      |
| 2.   | <p><b>Touch</b> the “Settings” icon ②. The “General Settings” screen displays.</p>  <p style="text-align: right;"><small>VMC-TS-006262</small></p> |
| 3.   | <p><b>Plug</b> the USB drive ③ into the port.</p>  <p style="text-align: right;"><small>VMC-TS-007852</small></p>                                  |

*Continued on next page*

Continued from previous page

4. **Scroll to “System Backup & Update.”**

**Touch the “Update System Software” ④ setting.**



**NOTICE** Do not remove the USB drive during the update process.

5. **Touch “Update Back End Software (BE)” to update the supporting software between the control board (CB) and interface board (IB). Select the ASBE.bin file ⑤. Touch the check mark ⑥.** The oven loads the selected software. **Touch the check mark ⑦** when the update is complete to restart the oven.



6. **Repeat steps 1 through 4.**

**Touch “Update Front End Software (FE)” to update the user interface software. Select the ASFE.bin file ⑧. Touch the check mark ⑨.** The oven loads the selected software. **Touch the check mark ⑩** when the update is complete to restart the oven.

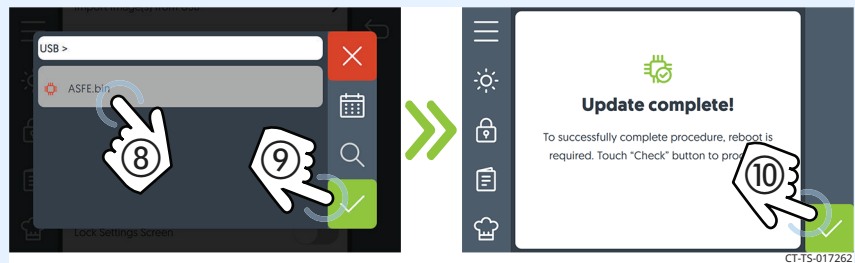

Continued on next page

Continued from previous page

7. **Repeat** steps 1 through 4.

**Touch** “Update Control Board (CB)” to update the control board. **Select** the file ⑪. **Touch** the check mark ⑫. The oven loads the selected software. The oven verifies the file and then updates the CB. **Touch** the check mark ⑬ when the update is complete to restart the oven.



8. **Remove** the USB drive.

9. **Touch** the “Info” icon ⑭ to validate the software versions.

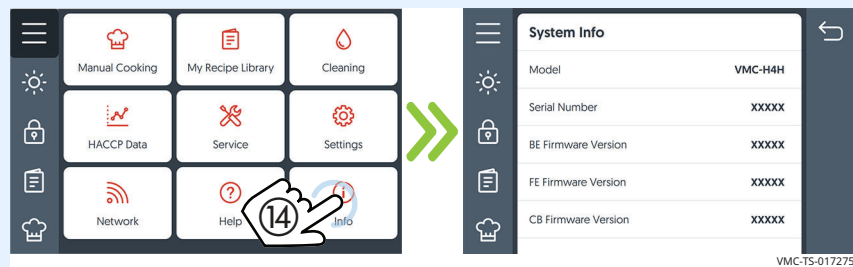

**Result**

The software has now been updated.

# How to Check for and Download Available Software Updates



## Background

- This procedure is to be done through the touchscreen on the Deluxe control, not through the ChefLinc™ oven management system.

The Check for Updates icon shows if there are waiting system software updates from ChefLinc™ or Alto-Shaam Technical Support. To download the most up to date oven software and register for email notifications when new software versions are released, visit <https://www.alto-shaam.com/en/customer-support/software-downloads>.

## Procedure

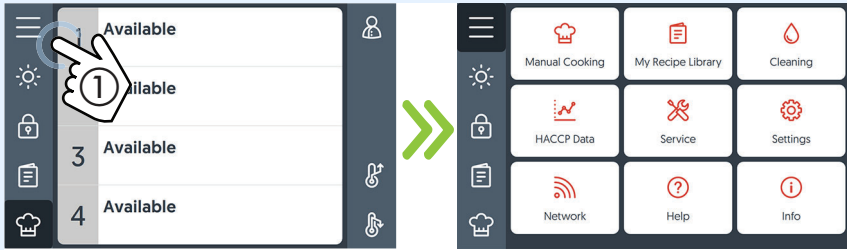
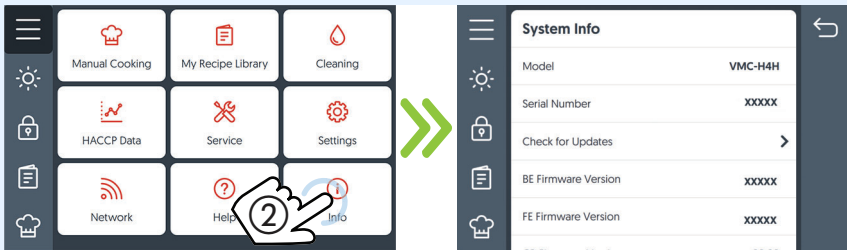
To check for updates, do the following.

| Step | Action  |
|------|---|
| 1.   | <p><b>Touch</b> the menu icon ①. The menu screen displays.</p>  <p style="text-align: right; font-size: small;">VMC-TS-006259</p>  |
| 2.   | <p><b>Touch</b> the “Info” icon ②. The “System Info” screen displays.</p>  <p style="text-align: right; font-size: small;">VMC-TS-008242</p>  |
| 3.   | <p><b>Touch</b> the “Check for Updates” icon ③. The display shows “Checking” and the oven downloads the latest software.</p>  <p style="text-align: right; font-size: small;">VMC-TS-018249</p> |

*Continued on next page*

Continued from previous page

4. Once the oven is done downloading the system software, it will show “Remote Update” screen. You can choose to update later or restart now.

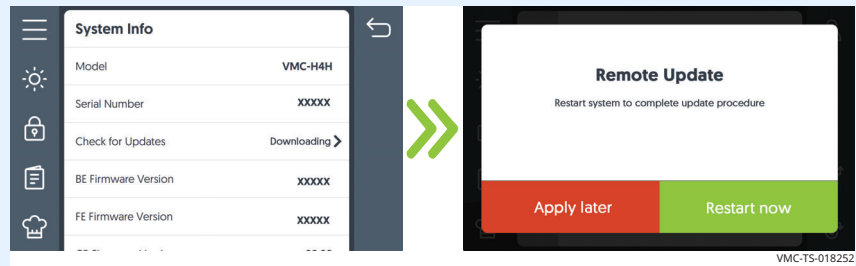

5. **Touch** the “Restart Now” icon ④. The display shows “Waiting for Reboot” until the oven restarts.

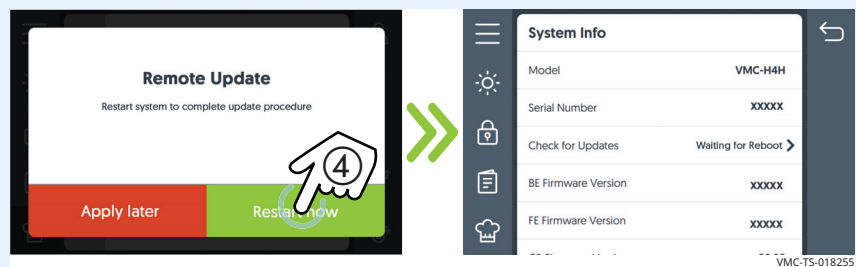

## Result

The oven's software is updated.

# How to Temporarily Change Languages

## Background

This procedure is to allow a quick change from one language to another on the oven display screen. The language will revert back to the original language when oven power is cycled.

## Procedure

To change language, do the following.

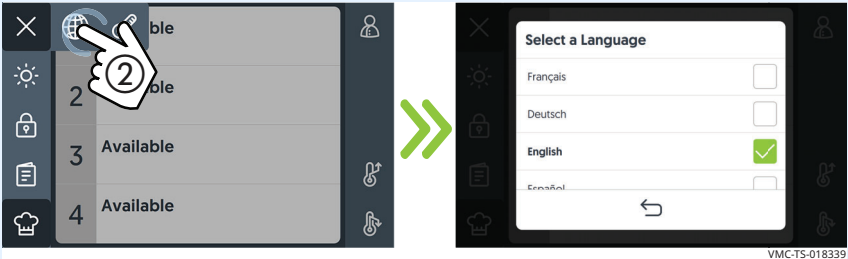
| Step | Action   |
|------|--|
| 1.   | <p><b>Touch and hold</b> the menu icon ①. The language select icon displays.</p>  <p style="text-align: right; font-size: small;">VMC-TS-018336</p>  |
| 2.   | <p><b>Touch</b> the language select icon ②. The “Select a Language” screen displays.</p> <p><b>Touch</b> the language you wish to use. It will translate the oven operating functions into that language. Recipes language will not change.</p>  <p style="text-align: right; font-size: small;">VMC-TS-018339</p> |

## Result

The oven’s language has been changed.

# How to Temporarily Change Temperature Units

## Background

This procedure is to allow a quick change between temperature units on the oven's display screen. The temperature unit will revert back to the original temperature units when oven power is cycled.

## Procedure

To temporarily change the temperature units, do the following.

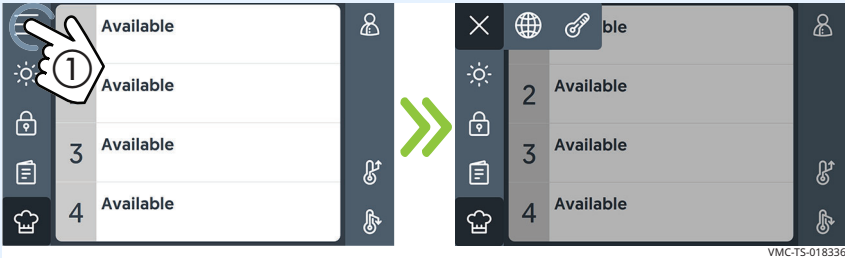
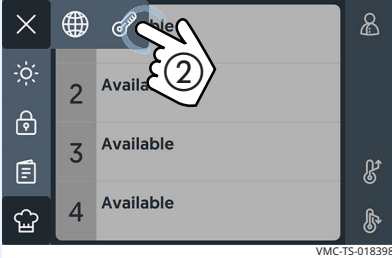
| Step | Action   |
|------|--|
| 1.   | <p><b>Touch and hold</b> the menu icon ①. The temperature unit icon displays.</p>  <p>The image shows two side-by-side screenshots of the oven's control panel. The left screenshot shows a hand with a circled '1' touching the menu icon (a gear with a plus sign) in the top left corner. The right screenshot shows the same panel with a temperature unit icon (a globe) and the word 'Available' appearing in the top right corner. A green double arrow points from the left to the right screenshot. The bottom right corner of the right screenshot is labeled 'VMC-TS-018336'.</p> |
| 2.   | <p><b>Touch</b> the temperature unit icon ②.</p> <p><b>Repeat</b> the procedure to toggle between temperature units.</p>  <p>The image shows a screenshot of the oven's control panel. A hand with a circled '2' is touching the temperature unit icon (a globe) in the top right corner. The bottom right corner of the screenshot is labeled 'VMC-TS-018398'.</p>   |

## Result

The oven's temperature units have now been changed.

# How to Change the Home Screen

**Procedure**

To change the home screen, do the following.

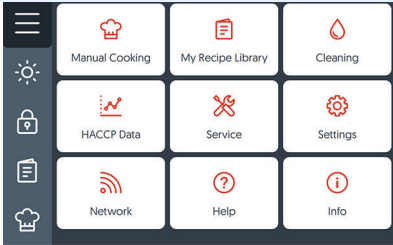
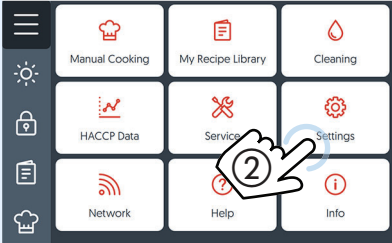
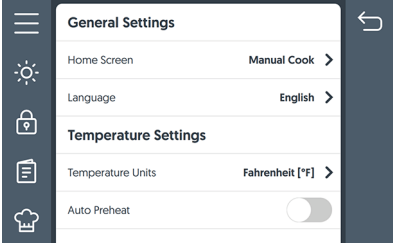
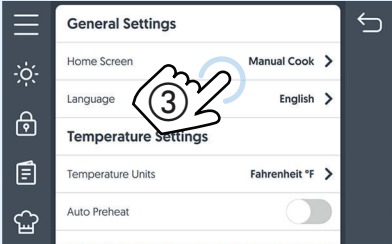
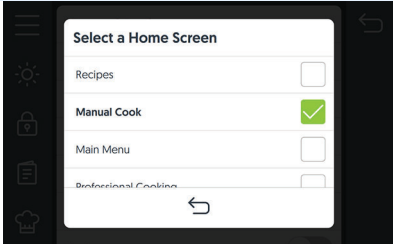
| Step | Action   |
|------|--|
| 1.   | <p><b>Touch</b> the menu icon ①. The menu screen displays.</p>   <p style="text-align: right;">VMC-TS-006259</p>                             |
| 2.   | <p><b>Touch</b> the “Settings” icon ②. The “General Settings” screen displays.</p>   <p style="text-align: right;">VMC-TS-006262</p>       |
| 3.   | <p><b>Touch</b> the “Home Screen” setting ③. The select home screen menu displays.</p>   <p style="text-align: right;">VMC-TS-008216</p> |

*Continued on next page*

Continued from previous page

4. **Select** your desired home screen from the list.  
**Touch** the check mark ④ to save the home screen setting.

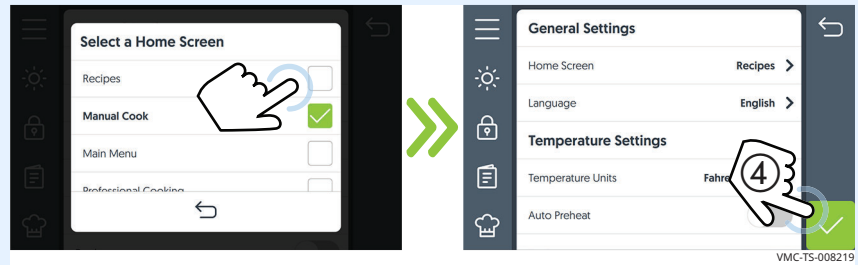

5. **Restart** the oven to reboot the home screen.

## Result

The home screen has now been changed.

# How to Change the Temperature Scale

## Procedure

To change the temperature scale from °F to °C and vice versa, do the following.

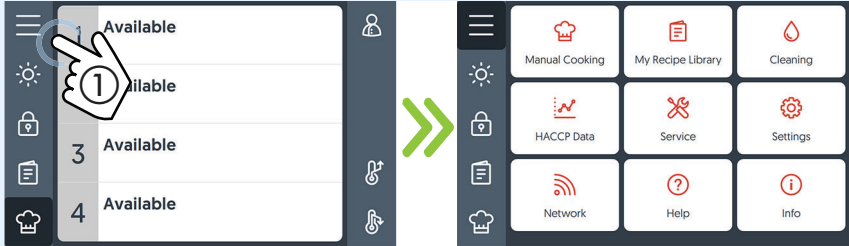
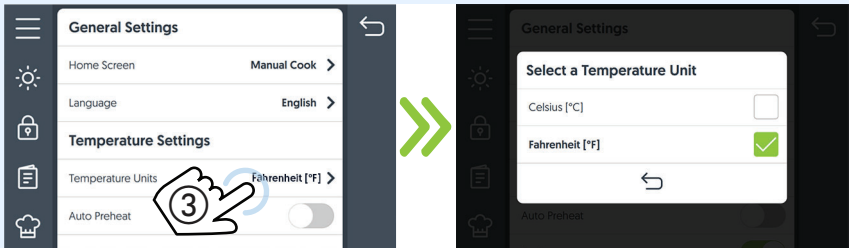
| Step | Action  |
|------|---|
| 1.   | <p><b>Touch</b> the menu icon ①. The menu screen displays.</p>  <p style="text-align: right;">VMC-TS-006259</p>   |
| 2.   | <p><b>Touch</b> the “Settings” icon ②. The “General Settings” screen displays.</p>  <p style="text-align: right;">VMC-TS-006262</p>                    |
| 3.   | <p><b>Touch</b> the “Temperature Units” setting ③. The select temperature units screen displays.</p>  <p style="text-align: right;">VMC-TS-008230</p> |

*Continued on next page*

Continued from previous page

4. **Select** your desired temperature scale.

**Touch** the check mark ④ to save the temperature scale setting.

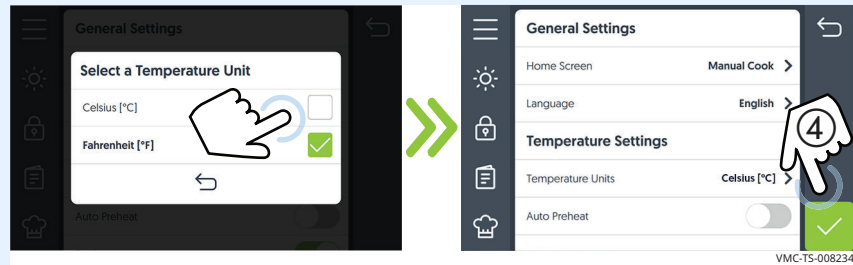

## Result

The temperature scale has now been changed.

# How to Change the Cooking Complete Notification Sound

## Background

When a cooking process is complete, the oven sounds an alert. This alert sound can be changed using the settings menu.

## Procedure

To change the cooking complete notification sound, do the following.

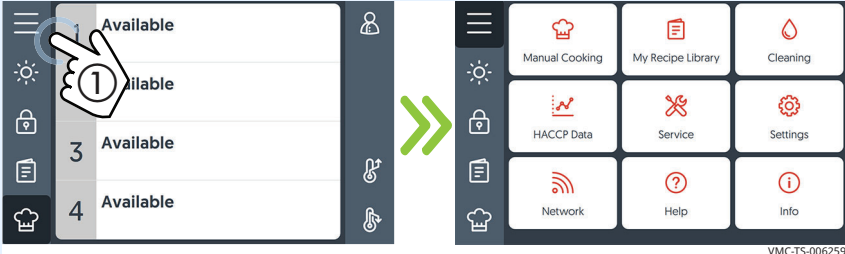
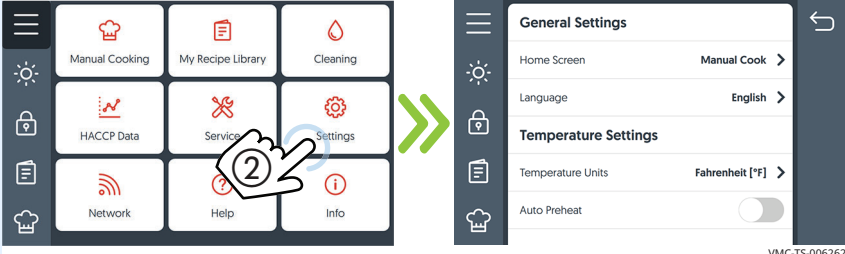
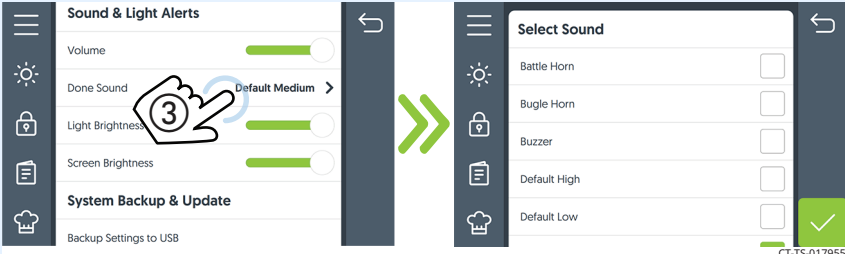
| Step | Action  |
|------|---|
| 1.   | <p><b>Touch</b> the menu icon ①. The menu screen displays.</p>  <p style="text-align: right; font-size: small;">VMC-TS-006259</p>   |
| 2.   | <p><b>Touch</b> the “Settings” icon ②. The “General Settings” screen displays.</p>  <p style="text-align: right; font-size: small;">VMC-TS-006262</p>   |
| 3.   | <p><b>Scroll</b> to “Sound &amp; Light Alerts.”</p> <p><b>Touch</b> the “Done Sound” ③ setting. The “Select Sound” screen displays.</p>  <p style="text-align: right; font-size: small;">CT-TS-017955</p> |

*Continued on next page*

Continued from previous page

4. **Select** your desired notification sound from the list. **Touch** the check mark ④.



**NOTE:** Touching a different sound option will play a sample sound.

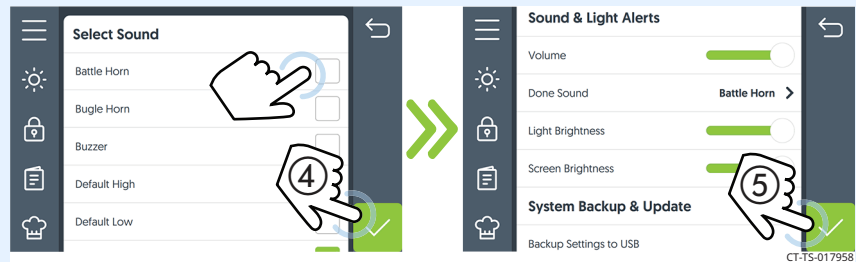

5. **Touch** the check mark ⑤ to save the setting.

## Result

The cooking complete notification sound has now been changed.

# How to Enable/Disable Automatic Preheat

## Background

Enabling the automatic preheat function preheats the oven upon start up to the set preheat temperature. Make sure to set your preheat temperatures. See topic *How to Preheat the Oven*.

## Procedure

To enable/disable automatic preheat, do the following.

| Step | Action   |
|------|--|
| 1.   | <p><b>Touch</b> the menu icon ①. The menu screen displays.</p> <p>VMC-TS-006259</p>  |
| 2.   | <p><b>Touch</b> the “Settings” icon ②. The “General Settings” screen displays.</p> <p>VMC-TS-006262</p>  |
| 3.   | <p><b>Touch</b> the “Auto Preheat” button ③. <b>Touch</b> the check mark ④. The automatic preheat function is now enabled.</p> <p><b>Repeat</b> the process to disable the automatic preheat function.</p> <p>CT-TS-013933</p> |

## Result

The automatic preheat function is now enabled/disabled.

# How to Enable and Use the Replay Function

## Background

When a cooking process is complete, the replay function repeats the same cooking process when you touch the replay icon. The replay function can be used for a programmed recipe or manual cook.

## Procedure

To enable the replay function, do the following.

| Step | Action |
|------|--------|
|------|--------|

1. **Touch** the menu icon ①. The menu screen displays.

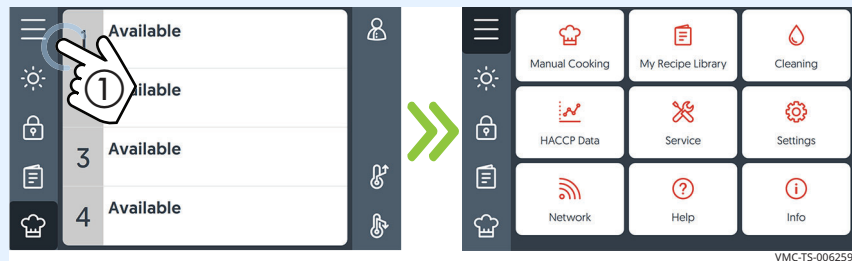

2. **Touch** the “Settings” icon ②. The “General Settings” screen displays.

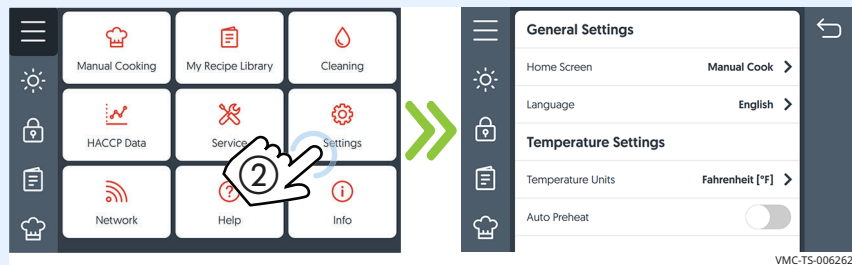

3. **Scroll** to the “Temperature Settings.”

**Touch** the Replay button ③. **Touch** the check mark ④. The replay function is now enabled.

**Repeat** the process to disable the replay function.

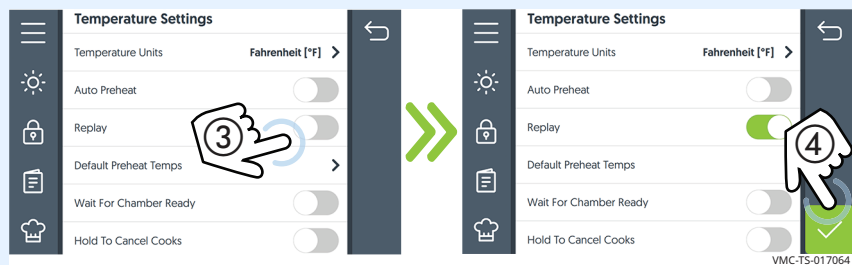

*Continued on next page*

Continued from previous page

**Using the replay function (if enabled)**

4. If the replay function is enabled, when the cooking process is complete, **touch** the replay icon ⑤ to repeat the previous cooking process.

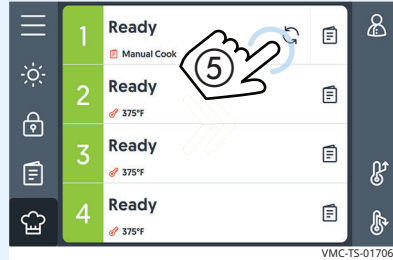

**Result**

The procedure is now complete.



# How to Enable/Disable “Press and Hold” Cook Cancel function

## Background

When the Press and Hold Cook Cancel function is enabled, users must press and hold the X on the cooking screen to cancel a cook. This is to prevent any accidental touches from canceling a cook.

## Procedure

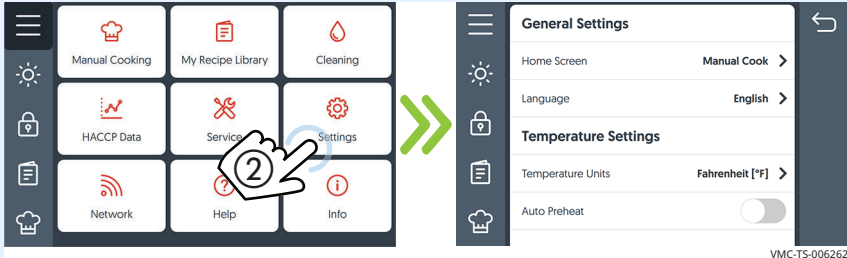
To enable/disable Press and Hold Cook Cancel function, do the following.

| Step | Action  |
|------|---|
| 1.   | <p><b>Touch</b> the menu icon ①. The menu screen displays.</p>  <p style="text-align: right;">VMC-TS-006259</p>   |
| 2.   | <p><b>Touch</b> the “Settings” icon ②. The “General Settings” screen displays.</p>  <p style="text-align: right;">VMC-TS-006262</p>   |
| 3.   | <p><b>Scroll</b> to the “Temperature” setting. <b>Touch</b> the “Hold to Cancel Cooks” button ③. <b>Touch</b> the check mark ④. The Press and Hold Cook Cancel function is now enabled.</p> <p><b>Repeat</b> the process to disable the Press and Hold Cook Cancel function.</p>  <p style="text-align: right;">VMC-TS-018478</p> |

## Result

The Press and Hold Cook Cancel function is now enabled/disabled.

# How to Lock Recipe Editing, Manual Cooking, or the Settings Screen

**Procedure**

To lock recipe editing, manual cooking, or the settings screen, do the following.

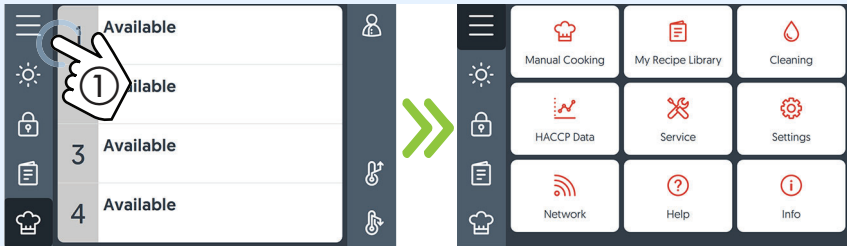
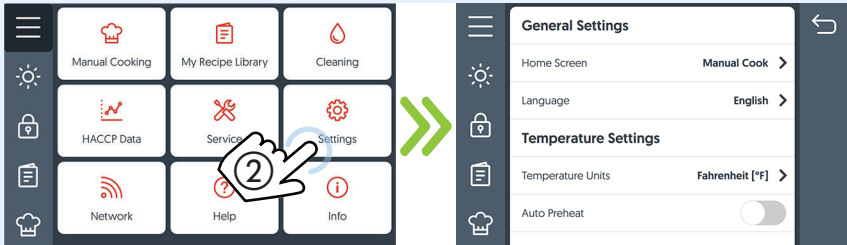
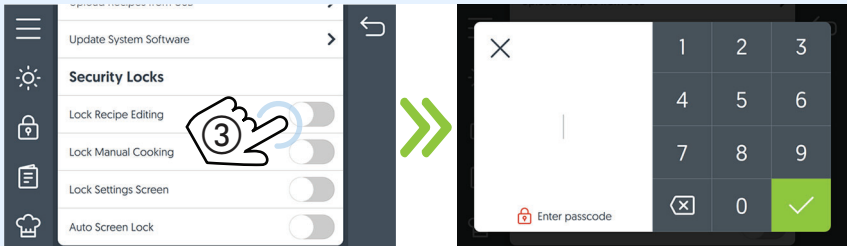
| Step | Action  |
|------|---|
| 1.   | <p><b>Touch</b> the menu icon ①. The menu screen displays.</p>  <p style="text-align: right; font-size: small;">VMC-TS-006259</p>   |
| 2.   | <p><b>Touch</b> the "Settings" icon ②. The "General Settings" screen displays.</p>  <p style="text-align: right; font-size: small;">VMC-TS-006262</p>  |
| 3.   | <p><b>Scroll</b> to the "Security Locks."</p> <p><b>Touch</b> the Lock Recipe Editing button ③. The "Enter passcode" screen displays.</p>  <p style="text-align: right; font-size: small;">CT-TS-013942</p> |

*Continued on next page*

Continued from previous page

4. **Create** a passcode ④ using the keypad. **Touch** the check mark ⑤).  
**Touch** the check mark ⑥ to lock recipe editing.

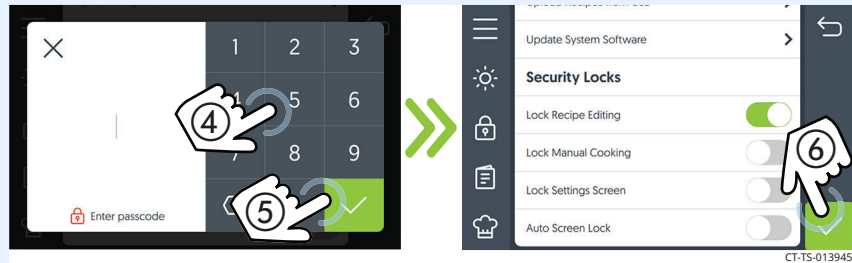

5. **Repeat** the process to lock manual cooking or lock the settings screen.

## Result

The lock recipe editing, manual cooking, or the settings screen are now locked.

# How to View Oven Information

## Background

This procedure is to be done through the touchscreen on the Deluxe control, not through the ChefLinc™ oven management system.

The oven information screen shows the oven model, serial number, and system software.

## Procedure

To view oven information, do the following.

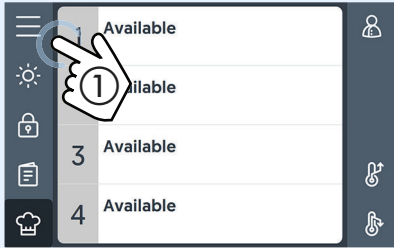
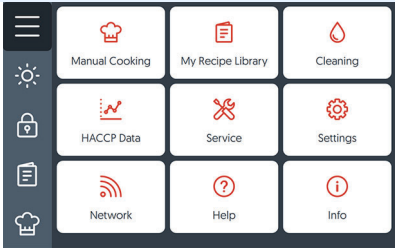
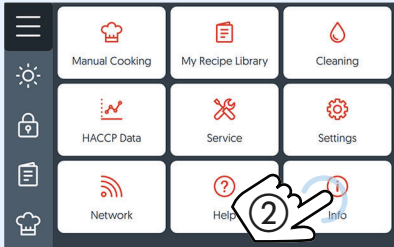
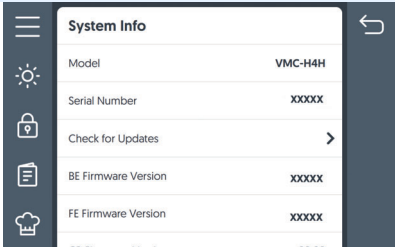
| Step | Action   |
|------|--|
| 1.   | <p><b>Touch</b> the menu icon ①. The menu screen displays.</p>     |
| 2.   | <p><b>Touch</b> the “Info” icon ②. The “System Info” screen displays.</p> <p><b>Scroll</b> to view the oven model, serial number, and system software.</p>   |

## Result

The oven’s information has been viewed.

# How to Download HACCP Data

## Before you begin

You will need a USB drive.

## Background

HACCP data provides automated record keeping, set-point validation, recipes used, dates and times. The data is stored until the information is downloaded. Once downloaded, the information is removed from the oven's memory. Best practice would be to download the information every 30 days to a USB drive. The file format is plain text file (.csv). The file can be viewed in Microsoft® Excel.

## Procedure

To download HACCP data, do the following.

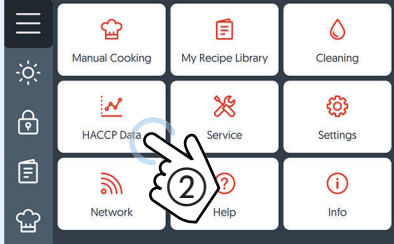
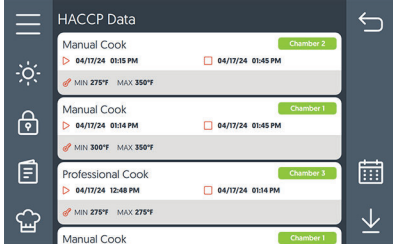
| Step | Action  |
|------|---|
| 1.   | <p><b>Touch</b> the menu icon ①. The menu screen displays.</p>  <p>VMC-TS-006259</p>   |
| 2.   | <p><b>Touch</b> the "HACCP Data" icon ②. The "HACCP Data" screen displays.</p>   <p>VMC-TS-008644</p> |

*Continued on next page*

Continued from previous page

3. **Plug** the USB drive ③ into the port.

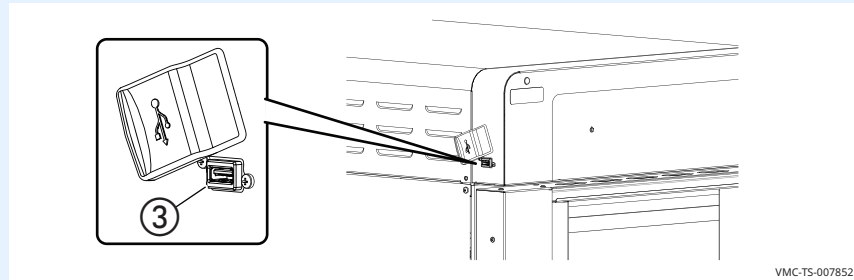

4. **Touch** the download icon ④.



**Loading the data**

The oven downloads the data onto the USB drive. When the process is complete, the download successful screen displays. **Touch** the check mark ⑤ to return to the menu screen. **Remove** the USB drive.

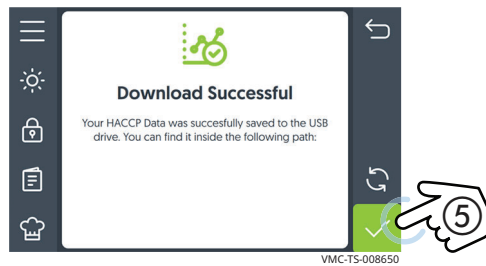

**Result**

The HACCP data has now been downloaded.

# Maintenance Schedule

## Requirements

- See topic *How to Clean the Oven*.
- Make sure the oven is cooled down and off—inside of chamber 140°F (60°C) or less.

## Daily

For daily maintenance, do the following.

- **Remove** any spills with disposable paper wipes or a damp cloth.
- **Wipe** the outside of the oven with a damp cloth.
- **Check** the screen for cracking or peeling. Contact Technical Service if needed.

## Weekly

For weekly maintenance, do the following.

- **Restart** the oven to reboot the screen.
- **Clean** the entire oven. **Make sure** to use a non-abrasive nylon scrub pad.
- **Inspect** and clean the grease filters (if equipped)
- Do not spray the cleaner directly into the fan openings located in the rear of the oven.

## Monthly

For monthly maintenance, do the following.

- **Inspect** and clean the cooling fan filters.

## Yearly

For yearly maintenance, do the following.



**NOTE:** Must be performed by a qualified professional.

- **Remove** the convection element(s) and inspect the return air path for grease buildup. **Remove** any grease buildup.
  - **Inspect** the catalyst for any signs of degradation (Vector H Series models only).
  - **Inspect** the heater flange area for grease leakage.
  - **Inspect** the motor flange area for grease leakage.
  - **Inspect** the door gaskets for correct shape and seal.
  - **Inspect** the inner and outer door window panes for cracking or chipping.
- 
- **Check and tighten** all wire connections.
  - **Check and tighten** all display, interface and control board connections.
  - **Check and tighten** the door hinges.

*Continued on next page*

*Continued from previous page*

- **Record** the software versions and update if necessary.
  - **Record** the amp draw of all elements on the service screen individually.
  - **Record** the incoming supply line voltage.
- 

- **Test** each chamber fan for correct operation.
- **Test** each chamber heater for correct operation.
- **Test** the chamber lights.

# How to Clean the Oven

## Precautions

**WARNING:** Burn hazard.

Wear eye protection and hand protection while cleaning the oven.

Do not spray cleaner into the oven while the blowers are running.

Allow the oven, racks, and jet plates to cool before cleaning the oven.

**NOTICE** Using improper cleaning procedures will damage the catalyst and void the warranty.

Do not spray the catalyst or any opening inside the oven with water or cleaning solution.

Do not use steel pads, wire brushes, or scrapers when cleaning.

## Daily cleaning procedure

For the daily cleaning, do the following.

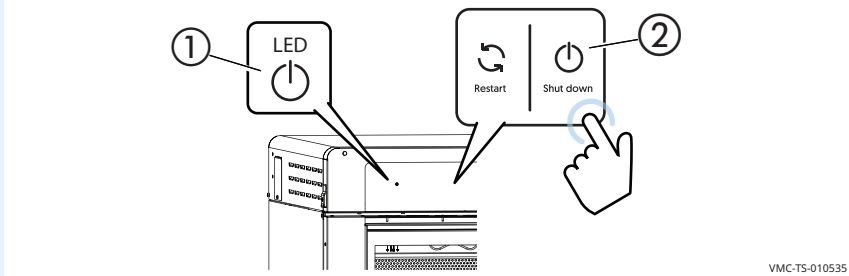
| Step | Action   |
|------|--|
| 1.   | <p><b>Touch and hold</b> the ON/OFF button ① until the Shut down options screen displays.</p>  <p><b>Touch</b> "Shut down" ②.</p> <p>The oven activates the blowers for the cool-down process. The cool-down process is complete when the oven deactivates the blowers and the display screen turns off. When the cool-down process is complete, it is safe to clean the oven.</p> |
| 2.   | <b>Remove</b> any spills with disposable paper wipes or a damp cloth.  |
| 3.   | <b>Wipe</b> the outside of the oven with a damp cloth.   |
| 4.   | <b>Wipe</b> the outside of the oven with a stainless steel cleaner.  |

*Continued on next page*

Continued from previous page

## Monthly or as needed cleaning procedure

For the monthly cleaning or as needed if the oven is dirty, do the following.

| Step | Action |
|------|--------|
|------|--------|

- |    |  |
|----|--|
| 1. | <b>Touch and hold</b> the ON/OFF button ① until the Shut down options screen displays. |
|----|--|

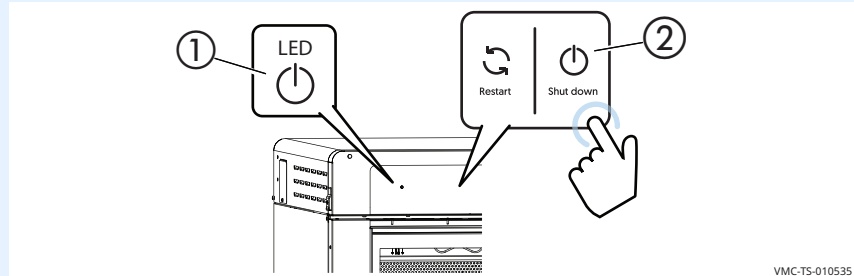

VMC-TS-010535

**Touch** "Shut down" ②.

The oven activates the blowers for the cool-down process. The cool-down process is complete when the oven deactivates the blowers and the display screen turns off. When the cool-down process is complete, it is safe to clean the oven.

- |    |   |
|----|---|
| 2. | <b>Remove</b> the cooking racks ① and jet plates ②. |
|----|---|



**CAUTION:** Personal injury hazard.

Use hand protection when handling the jet plates.

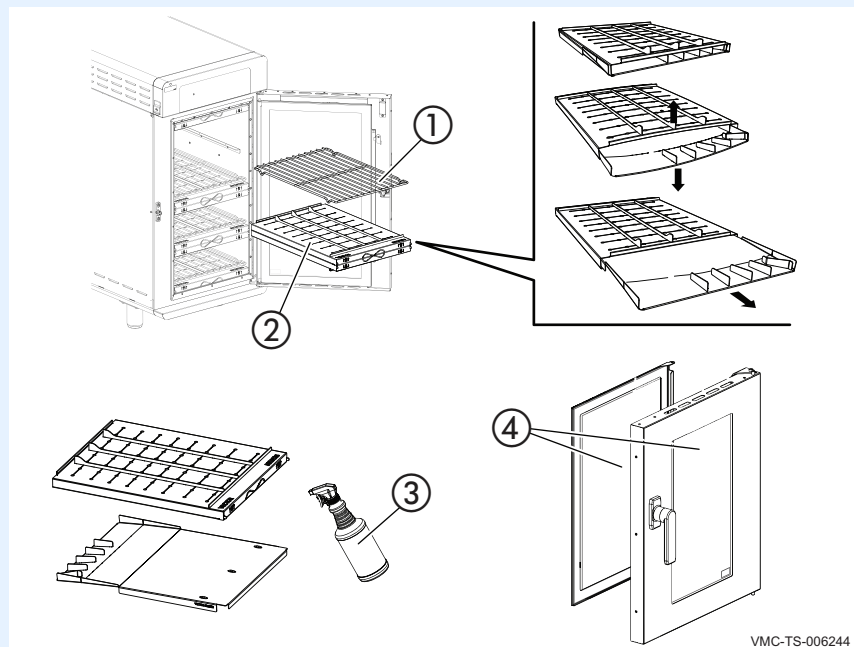

VMC-TS-006244

Continued on next page

Continued from previous page

3. **Separate** the jet plates. Flexing the jet plates outward can aid in separating the jet plates.
4. **Spray** the cooking racks and jet plates with Alto-Shaam non-caustic oven cleaner (3), CE-46828. Follow safety instructions on cleaner bottle. Let the cleaner work for 3–5 minutes. **Scrub** with a non-abrasive scrub pad. **Rinse** with water. **Wipe** with a soft cloth.
5. **Remove** the grease filters (5) if equipped.

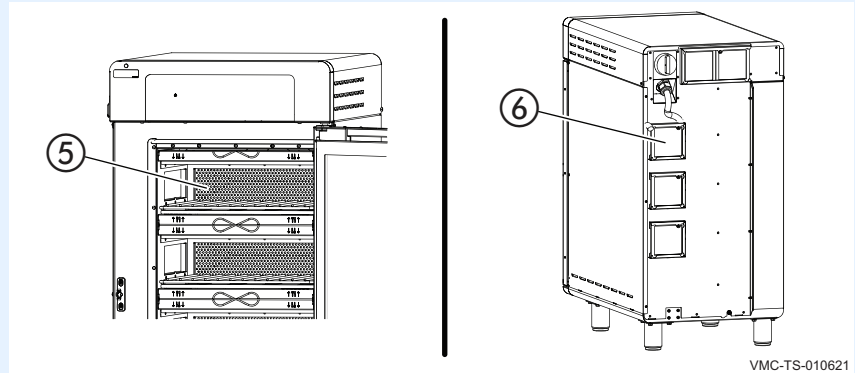

6. **Spray** the interior surfaces of the oven with Alto-Shaam non-caustic oven cleaner, CE-46828. Also spray the grease filters. Let the cleaner work for 3–5 minutes. **Scrub** with a non-abrasive scrub pad. **Remove** any residue with a water-soaked towel.
7. **Remove** the cooling fan filters (6). Clean with a mild cleaner and rinse with hot water.

**i** **NOTE:** Replace the cooling fan filters at least once a year.

8. **Re-install** the grease filters and the cooling fan filters.
9. **Clean** the door glass (4) with Windex® or equivalent glass cleaner.
10. **Re-install** the jet plates and cooking racks. See topic *How to Install the Jet Plates*.

**i** **NOTE:** Make sure the jet plates are installed correctly. The nozzles on the jet plates should be pointing towards the food.

Continued on next page

*Continued from previous page*

11. **Spray** the exterior of the oven with stainless steel polish. **Wipe** the exterior of the oven with a non-abrasive scrub pad. Follow safety instructions on the bottle of the stainless steel polish.

**NOTICE**

Use only non-caustic cleaners.

Do not spray directly into the fan openings on the rear of the oven.

Do not use cleaners that contain sodium hydroxide (lye) or phosphorus.

**Result**

The oven is now clean.

# How to Set the Cleaning Frequency

## Background

The user can set a cleaning frequency to schedule when the unit will go through a cleaning cycle. The cleaning frequency can be set by hours or day and time.

## Procedure

To set the cleaning frequency, do the following.

| Step | Action   |
|------|--|
| 1.   | <p><b>Touch</b> the menu icon ①. The menu screen displays.</p> <p>VMC-TS-006259</p>  |
| 2.   | <p><b>Touch</b> the “Settings” icon ②. The “General Settings” screen displays.</p> <p>VMC-TS-006262</p>                              |
| 3.   | <p><b>Scroll</b> ③ until “Cleaning Settings” displays. <b>Touch</b> the “Set Cleaning Frequency” ④ setting.</p> <p>VMC-TS-018210</p> |

*Continued on next page*

Continued from previous page

## Setting the cleaning frequency hours

4. **Touch** the “Hours” setting ⑤ to set the cleaning frequency hours. **Enter** the desired hours using the key pad. **Touch** the check mark.

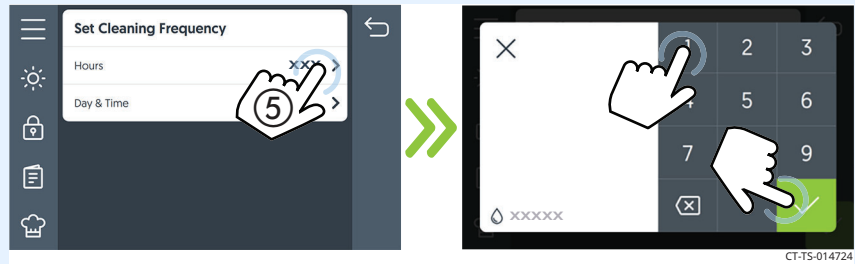

CT-TS-014724

## Setting the cleaning frequency day and time

5. **Touch** the “Date & Time” setting ⑥ to set the day and time for cleaning. **Touch** the check box ⑦ next to a day to set it. **Touch** the check mark.

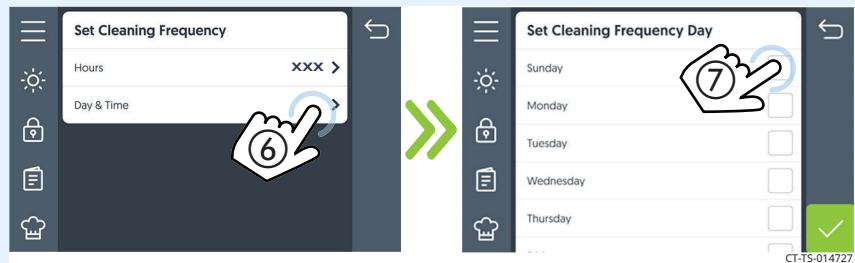

CT-TS-014727

6. The “Set cleaning frequency time” screen will display.  
**Touch** the “AM”/“PM” button ⑧ to choose whether the cleaning time is set for AM or PM.  
**Enter** the time of day for the cleaning. **Touch** the check mark.  
**Touch** the check mark on the “Set Cleaning Frequency” setting screen.

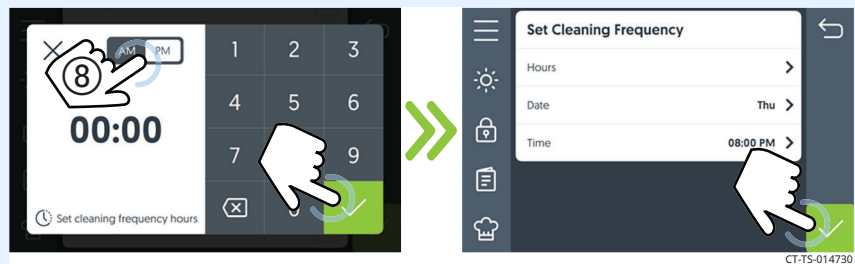

CT-TS-014730

## Result

The cleaning frequency has been set.

# How to View the Cleaning Log

## Background

The cleaning log allows the user to view details about the previously completed cleanings on the unit.

## Procedure

To view the cleaning log, do the following.

| Step | Action |
|------|--------|
|------|--------|

1. **Touch** the menu icon ①. The menu screen displays.



2. **Touch** the “Cleaning” icon ②. The “Cleaning” screen displays.

**NOTE:** After cleaning the oven, touch the “Perform Clean” ③ setting to record a cleaning log.

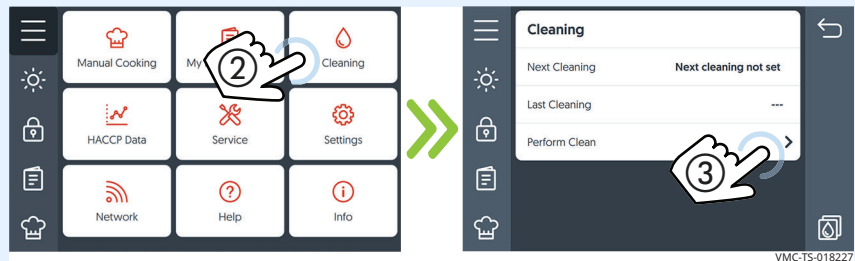

3. **Touch** the cleaning log icon ④. The “Cleaning log” screen displays.

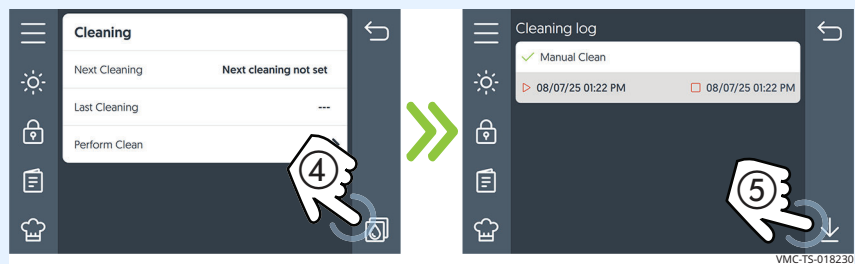

**NOTE:** Touch the download icon ⑤ to download the cleaning logs to a USB drive.

## Result

The cleaning log has been viewed.

This page is intentionally left blank.

# Error Codes

| Code  | Description  | Parameters that trigger the error   | Possible Cause(s)   |
|-------|--|---|---|
| E-3   | Motor error  | No cavity motor rotation detected for greater than 30 seconds.  | <ol style="list-style-type: none"> <li>1. Power down control using on/off icon.</li> <li>2. Cycle power to the oven either by unplugging the unit or by turning the main power switch off and then back on.</li> <li>3. Resume use of oven. If error reappears contact a service provider.</li> </ol>   |
| E-10  | Sensor short   | Short circuit detected on sensor wires.   | <ol style="list-style-type: none"> <li>1. Power down control using on/off icon.</li> <li>2. Cycle power to the oven either by unplugging the unit or by turning the main power switch off and then back on.</li> <li>3. Resume use of oven. If error reappears contact a service provider.</li> </ol>   |
| E-11  | Sensor open  | Cavity air sensor reading > 650°F (343°C).  | <ol style="list-style-type: none"> <li>1. Power down control using on/off icon.</li> <li>2. Cycle power to the oven either by unplugging the unit or by turning the main power switch off and then back on.</li> <li>3. Resume use of oven. If error reappears contact a service provider.</li> </ol>   |
| E-30  | Unit under temperature   | Cavity temperature remains 25°F (14°C) below target for more than 90 minutes.                           | <ol style="list-style-type: none"> <li>1. Verify Oven was preheated before loading product.</li> <li>2. Press High Limit Switch to reset.</li> <li>3. Power down control using on/off icon.</li> <li>4. Cycle power to the oven either by unplugging the unit or by turning the main power switch off and then back on.</li> <li>5. Resume use of oven. If error reappears contact a service provider.</li> </ol> |
| E-31  | Electronics over temperature   | Control board temperature exceeds 158°F (70°C) and/or interface board temperature exceeds 184°F (84°C). | <ol style="list-style-type: none"> <li>1. Remove and clean fan filters.</li> <li>2. Verify cooling fan is operating.</li> <li>3. Resume use of oven. If error reappears contact a service provider.</li> </ol>  |
| E-94  | Interface Board - Control Board communication error                                | No signal transfer for more than 5 seconds between the interface board and the control board.           | <ol style="list-style-type: none"> <li>1. Power down control using on/off icon.</li> <li>2. Cycle power to the oven either by unplugging the unit or by turning the main power switch off and then back on.</li> <li>3. Resume use of oven. If error reappears contact a service provider.</li> </ol>   |
| E-108 | Bi-metal thermostat open   | Open circuit detected across bi-metal switch.   | <ol style="list-style-type: none"> <li>1. Remove and clean fan filters.</li> <li>2. Verify cooling fan is operating.</li> <li>3. Resume use of oven. If error reappears contact a service provider.</li> </ol>  |
| E-109 | High limit error<br><b>Note:</b> Contact an authorized Alto-Shaam service partner. | Open circuit detected across high limit switch.   | <ol style="list-style-type: none"> <li>1. Allow oven to cool down for 30 minutes.</li> <li>2. Press High Limit Switch to Reset</li> <li>3. Resume use of oven. If error reappears, contact a service provider.</li> </ol>   |

# What to do if the Fan Indicator Light Illuminates

## Procedure

If the fan indicator light ① illuminates, do the following.

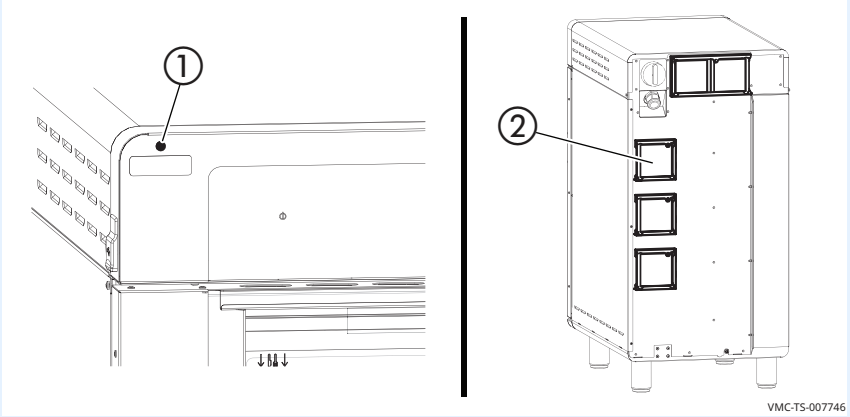
| Step | Action   |
|------|--|
| 1.   | <p><b>Turn off</b> the oven and allow it to cool.</p> <p><b>Remove</b> the filters ②.</p>  |
|      |  <p style="text-align: right; font-size: small;">VMC-TS-007746</p>                                      |
| 2.   | <b>Clean</b> the filters with mild soap and water.   |
| 3.   | <b>Re-install</b> the filters.   |
| 4.   | <b>Resume</b> operation of the oven.   |
|      | <p><b>NOTE:</b> If the fan indicator light remains on, the appliance is malfunctioning. Disconnect the appliance from the power supply and have it serviced by a qualified technician.</p> |

## Result

The procedure is now complete.

# What to do if the High Limit Screen Displays

## Procedure

If the high limit screen displays, do the following.

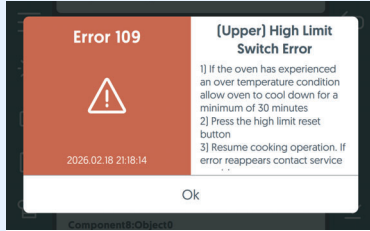
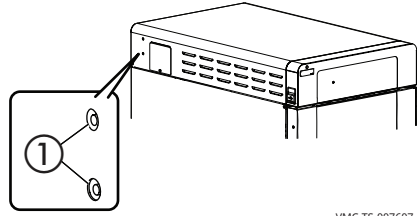
| Step | Action   |
|------|--|
| 1.   | <p><b>Press and release</b> the high limit temperature reset button(s) ①.</p> <div style="display: flex; align-items: center;">   </div> <p style="text-align: right; font-size: small;">VMC-TS-007607</p> |
| 2.   | <p><b>Resume</b> operation of the oven.</p> <div style="border: 1px solid gray; padding: 5px; margin-top: 10px;"> <p><b>NOTE:</b> If the high limit screen continues to display, the appliance is malfunctioning. Turn off the appliance and have the oven serviced by a qualified technician.</p> </div>  |

## Result

The procedure is now complete.

# Cheflincv2.alto-shaam.com/# is Not Available on Your Device

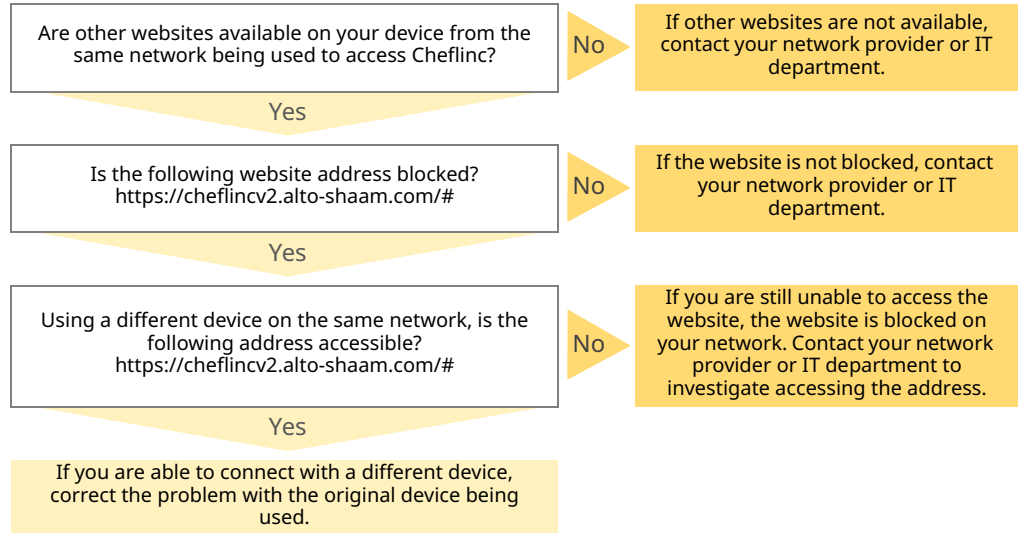

# Cannot Connect to cheflincv2.alto-shaam.com/#

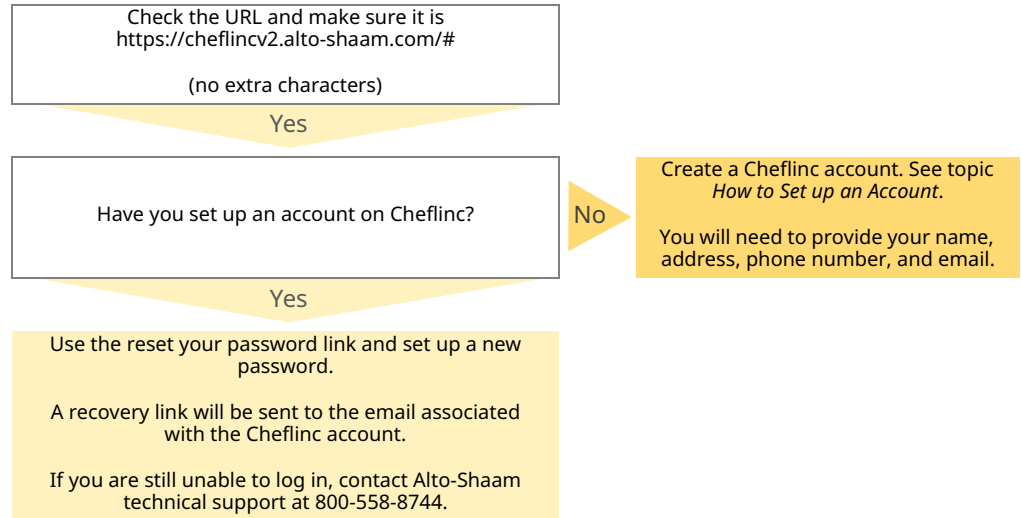

# The Oven is not Displayed on the Dashboard

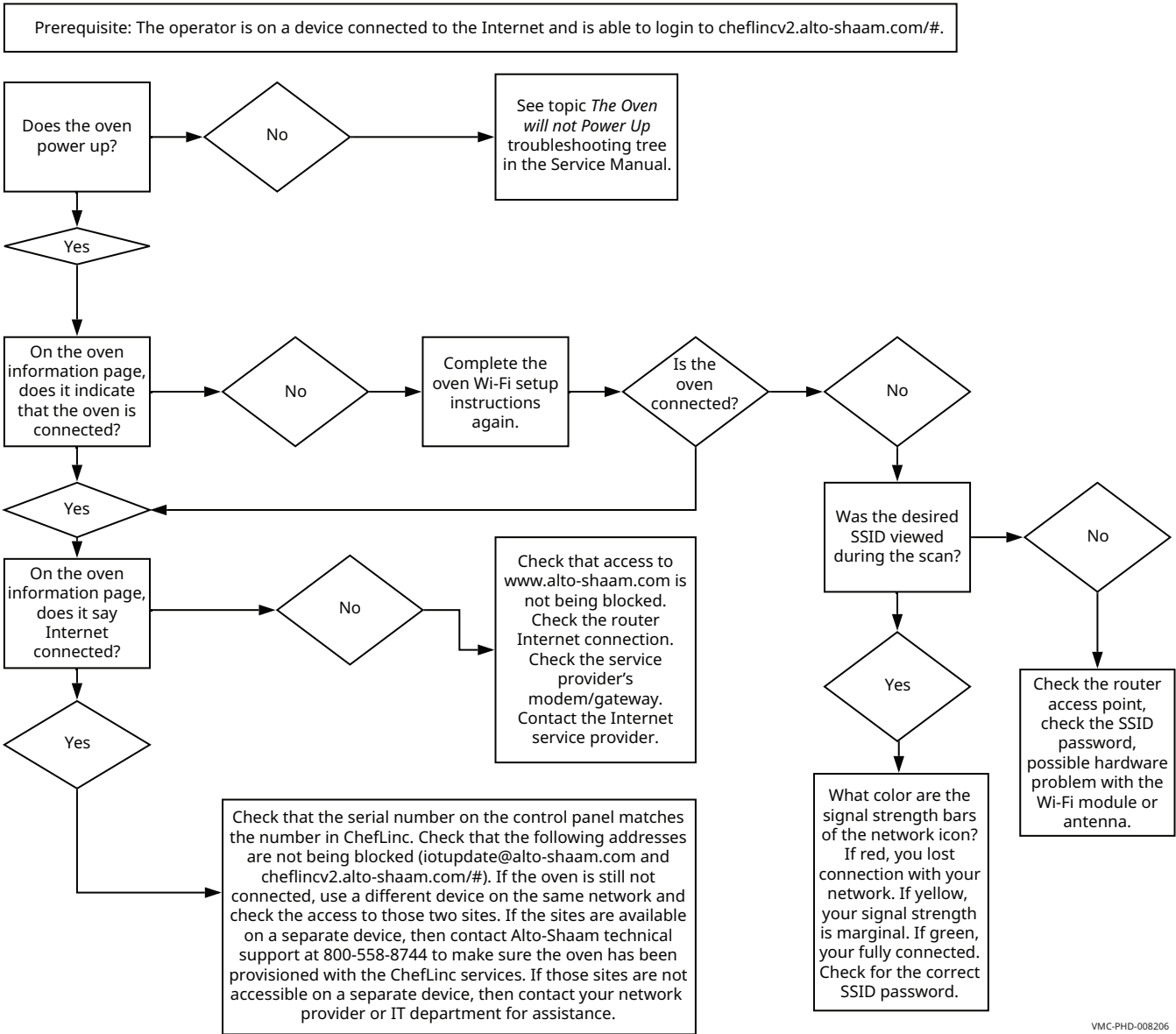

VMC-PHD-008206

# Unable to Assign Recipes from the Dashboard to Ovens in the Field

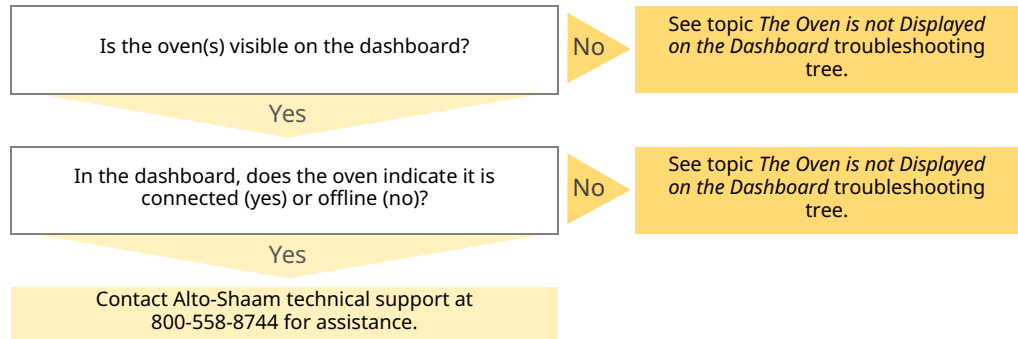

This page is intentionally left blank.

# Notifications

---

**FCC ID: N6C-SDPAC**

**IC ID: 4908A-SDPAC**

## **NOTICE**

### **Federal Communication Interference Statement (United States only)**

This equipment has been tested and found to comply with the limits for a class B digital device, pursuant to Part 15 of the FCC rules. These limits are designed to provide reasonable protection against harmful interference in a residential installation. This equipment generates, uses, and can radiate radio frequency energy and, if not installed and used in accordance with the instructions, may cause harmful interference to radio communications. However, there is no guarantee that interference will not occur in a particular installation. If this equipment does cause harmful interference to radio or television reception, which can be determined by turning the equipment off and on, the user is encouraged to try to correct the interference by one or more of the following measures:

- Re-orient or relocate the receiving antenna
- Increase the separation between the equipment and receiver
- Connect the equipment to an outlet on a circuit different from that to which the receiver is connected
- Consult the dealer or an experienced radio/TV technician for help

The antenna(s) used for this transmitter must be installed to provide a separation distance of at least 20 cm from all persons and must not be co-located or operating in conjunction with any other antenna or transmitter.

**Canadian Department of Communications Industry Canada Notice  
(Canada only)**

This Class B digital apparatus complies with Canadian ICES-003.

**FCC Rules, Part 15 / Industry Canada**

This device complies with Part 15 of FCC Rules and Industry Canada license-exempt RSS standard(s). Operation is subject to the following two conditions:

- (1) This device may not cause harmful interference, and
- (2) This device must accept any interference, including interference that may cause undesired operation of this device.

This equipment complies with FCC/IC radiation exposure limits set forth for an uncontrolled environment and meets the FCC radio frequency (RF) Exposure Guidelines in Supplement C to OET65 and RSS-102 of the IC radio frequency (RF) Exposure rules. This equipment should be installed and operated keeping the radiator at least 20 cm or more away from a person's body.

Under Industry Canada regulations, this radio transmitter may only operate using an antenna of a type and maximum (or lesser) gain approved for the transmitter by Industry Canada. To reduce potential radio interference to other users, the antenna type and its gain should be so chosen that the equivalent isotropically radiated power (e.i.r.p.) is not more than that necessary for successful communication.

This radio transmitter (identify the device by certification number, or model number if Category II) has been approved by Industry Canada to operate with the antenna types listed below with the maximum permissible gain and required antenna impedance for each antenna type indicated. Antenna types not included in this list, having a gain greater than the maximum gain indicated for that type, are strictly prohibited for use with this device.

For product available in the USA/Canada market, only channels 1–11 can be operated. Selection of other channels is not possible. If this device is to be operated in the 5.15~5.25GHz frequency range, it is restricted to indoor environments only.

Antenna: Proprietary

Antenna gain information: Embedded Antenna: 3.25dBi (2.4 GHz), 5.0dBi (5 GHz)

Frequency Tolerance: +/-20ppm

**WARNING**

The FCC / The Industry Canada regulations provide that changes or modifications not expressly approved by the party responsible for compliance could void the user's authority to operate the equipment.

**General Specifications**

|                                   |  |
|-----------------------------------|--|
| <b>Chipset:</b>                   | QCA9377-3, (Qualcomm Atheros)  |
| <b>Host Interface:</b>            | Wifi: SDIO v3.0; BT: High Speed UART   |
| <b>Operating Voltage:</b>         | 3.30 VDC +/- 5%  |
| <b>Operating Temperature:</b>     | -20 to +70 degrees C   |
| <b>Dimensions:</b>                | 18.0 x 13.0 x 2.2 mm (L x W x D)   |
| <b>Connector Type:</b>            | 52-pin proprietary   |
| <b>Radio Specifications:</b>      | 802.11b/g/n: 2.412–2.484 GHz;<br>802.11a/n: 5.18–5.825 GHz<br>BT: 2.402–2.480 GHz  |
| <b>Link Rates (1 stream):</b>     | IEEE 802.11b: 1–11 Mbps<br>IEEE 802.11g: 6–54 Mbps<br>IEEE 802.11a: 6–54 Mbps<br>IEEE 802.11n HT20: 6.5–65.0 Mbps<br>IEEE 802.11n HT40: 13.5–135.0 Mbps<br>IEEE 802.11ac VHT20: 6.5–78.0 Mbps<br>IEEE 802.11ac VHT40: 13.5–180.0 Mbps<br>IEEE 802.11ac VHT80: 29.3–390.0 Mbps  |
| <b>Modulation Modes:</b>          | OFDM (256QAM, 64QAM, 16QAM, QPSK, BPSK), DSSS (CCK, DQPSK, DBPSK), GFSK (1Mbps), $\pi/4$ DQPSK (2Mbps), 8DQPSK (3Mbps)   |
| <b>Hardware Encryption:</b>       | WEP, WPA/WPA2 (TKIP/AES-CCMP), WAPI  |
| <b>Quality of Service (QoS):</b>  | WMM, WMM-PS, 802.11e   |
| <b>Japanese Security Standard</b> | This oven cannot be connected directly to the telecommunications circuits (or public wireless LANs) of any telecommunication carriers (example: mobile communications carriers, fixed communications carriers, or Internet providers). In the case of connecting the oven to the Internet, make sure to connect it via a router. |

# Conditions for Ovens Installed in New York City

---

- Operating instructions in the manual must be read and understood by all persons using the appliance. The person responsible for training of the operators is responsible for the safekeeping of the manual.
- Prior to installation, plans specifying the exact product name/model number and dimensions/specifications shall be filed with and approved by New York City Department of Buildings (DOB). A copy of DOB docketed (Stamped, numbered and dated) plans shall be transmitted to the Fire Department for review and approval, as applicable.
- Installation, maintenance, and cleaning procedures shall comply with all applicable New York City Fire Code, New York City Electric Code, New York City Construction Codes (including the Building Code and the Mechanical Code), and rules.
- The cooking equipment shall be used for light duty cooking and food warming only, and shall be provided with catalyst to limit the emission of grease-laden air.
- The cooking equipment shall be installed in an area approved by the New York City Department of Buildings.
- Underwriters Laboratories, Inc.'s listing requirements and manufacturer's installation, operation and maintenance requirements shall be complied with.
- The cooking equipment (including filters and catalyst) shall be inspected, cleaned and replaced if necessary, by a qualified person holding a Fire Department Certificate of Fitness. The catalyst shall be maintained in proper working order. A record of such inspection and cleaning shall be kept on the premises for inspection.
- All installations are subject to inspection by representatives of the Bureau of Fire Prevention which may result in additional requirements being imposed.
- The Fire Department's condition of approval shall be provided to all New York City buyers, users and installers.
- Certificate of Approval number shall be plainly and permanently stamped or otherwise fixed upon each product by the manufacturer or the local representative of the manufacturer.
- The equipment's technology does not violate any patent, trade name, trade secret or other intellectual right.
- The Certificate of Approval does not constitute an endorsement or recommendation of the product by the Fire Department, but is a certification that the product is acceptable as of the date of issuance.
- The Fire Department may withdraw this approval at any time in the event there is a reasonable doubt that the product does not operate or perform as required by code, the conditions of the resolution or as represented in the application.
- Any end user who fails to comply with the conditions as outlined in this approval will be subject to enforcement action.

# Warranty

## Introduction

Alto-Shaam, Inc. warrants to the original purchaser only, that any original part found to be defective in material or workmanship will be replaced with a new or rebuilt part at Alto-Shaam's option, subject to provisions hereinafter stated.

## Warranty Period

The original parts warranty period is as follows:

- For all other original parts, one (1) year from the date of installation of appliance or fifteen (15) months from the shipping date, whichever occurs first.
- The labor warranty period is one (1) year from the date of installation or fifteen (15) months from the shipping date, whichever occurs first.
- Alto-Shaam will bear normal labor charges performed during standard business hours, excluding overtime, holiday rates or any additional fees.
- For the refrigeration compressor, if installed, the warranty period is five (5) years from the date of original installation of the appliance.
- For heating elements on Halo Heat® Cook and Hold ovens, the warranty period is for as long as the original owner owns the oven. This warranty period applies to units sold after 2/1/2009 and excludes holding-only ovens.
- To be valid, a warranty claim must be asserted during the applicable warranty period. This warranty is not transferable.

## Exclusions

This warranty does not apply to:

- Calibration.
- Replacement of light bulbs, rubber gaskets, grease filters, air filters, racks, jet plates, and/or the replacement of glass due to damage of any kind.
- Equipment damage caused by accident, shipping, improper installation or alteration.
- Equipment used under conditions of abuse, misuse, carelessness or abnormal conditions, including but not limited to, equipment subjected to harsh or inappropriate chemicals, including but not limited to, compounds containing chloride or quaternary salts, poor water quality, or equipment with missing or altered serial numbers.
- Equipment damage caused by use of any cleaning agents other than those recommended by Alto-Shaam, including but not limited to damage due to chlorine or other harmful chemicals.
- Any losses or damage resulting from malfunction, including loss of food product, revenue, or consequential or incidental damages of any kind.
- Equipment modified in any manner from original model, substitution of parts other than factory authorized parts, unauthorized removal of any parts including legs, or unauthorized addition of any parts.

*Continued on next page*

*Continued from previous page*

- Equipment damage incurred as a direct result of poor water quality\*, inadequate maintenance of steam generators and/or surfaces affected by water. Water quality and required maintenance of steam generating equipment is the responsibility of the owner/operator.
  - Equipment damage incurred as a result of not following the required maintenance schedule published in the manuals for the equipment.
- 

## **Conclusion**

This warranty is exclusive and is in lieu of all other warranties, express or implied, including the implied warranties of merchantability and fitness for a particular purpose. No person except an officer of Alto-Shaam, Inc. is authorized to modify this warranty or to incur on behalf of Alto-Shaam any other obligation or liability in connection with Alto-Shaam equipment.

*\*Refer to the product spec sheet for water quality standards.*

# DECLARATION OF CONFORMITY

**Manufacturer:**  
Alto-Shaam, Inc.  
W164 N9221 Water Street  
Menomonee Falls, WI 53202-0450  
U.S.A.



|                               |  |
|-------------------------------|--|
| <b>EQUIPMENT TYPE:</b>        | Household and Similar Electric Appliances  |
| <b>EQUIPMENT DESCRIPTION:</b> | Commercial Electric Convection Ovens   |
| <b>MODEL NUMBER:</b>          | VMC-H2, VMC-H3, VMC-H4, VMC-H2H,<br>VMC-H2HW VMC-H3H, VMC-H3HW,<br>VMC-H4H, VMC-F3E, VMC-F4E with or without a<br>V after the dash.<br>CMC-H2H, CMC-H3H with or without option VH  |
| <b>APPLIED DIRECTIVES:</b>    | Low Voltage Directive 2014/35/EU<br>MD (Machinery Directive) 2006/42/EC<br>EMC – 2014/30/EC<br>RED – 2014/53/EU  |
| <b>APPLIED STANDARDS:</b>     | EN 60335-1:2012+AC:2014 + A11:2014<br>EN 60335-2-42:2003 + A1:2008 + A11:2012<br>AS/NZS 60335.1:2011 + A1:2012 +<br>A2:2014 + A3:2015. AS/NZS 60335.1:2020<br>EN 55014-1: CISPR 14, EN 55014-2: CISPR 14<br>EN 62479, EN 300 328, EN 301 489, EN 300 893 |



*We, the undersigned, hereby declare that the equipment specified above conforms to the above Directives and Standards*

Manufacturer Name:  
**ALTO-SHAAM INC.**  
NAME: Christa Pieper  
TITLE: Certification Manager

SIGNATURE:   
DATE: March 4<sup>th</sup> 2022



DECLARATION OF CONFORMITY

# DECLARATION OF CONFORMITY

**Manufacturer:**  
Alto-Shaam, Inc.  
W164 N9221 Water Street  
Menomonee Falls, WI 53202-0450



**EQUIPMENT TYPE:** Household and Similar Electric Appliances

**EQUIPMENT DESCRIPTION:** Commercial Convection Ovens

**MODEL NUMBER:** VMC-H2, VMC-H2H, VMC-H2HW, VMC-H3, VMC-H3H, VMC-H3HW, VMC-H4, VMC-H4H, VMC-F3E, VMC-F4E, CMC-H2H, CMC-H3H with or without option VH

**APPLIED UK REGULATIONS:**

- Supply of Machinery (Safety) Regulations 2008
- Electromagnetic Compatibility Regulations 2016
- The Restriction of the Use of Certain Hazardous Substances in Electrical and Electronic Equipment Regulations 2012
- Radio Equipment Regulations 2017

**APPLIED STANDARDS:**

EN 60335-1:2012+AC:2014 + A11:2014  
EN 60335-2-42:2003 + A1:2008 + A11:2012  
EN 55014-1:2018, EN 55014-2:2016



*We the undersigned, hereby declare that the equipment specified above conforms to the above Directives and Standards*

Manufacturer Name:  
**ALTO-SHAAM INC.**  
**NAME:** Christa Pieper  
**TITLE:** Certification Manager

**SIGNATURE:**   
**DATE:** March 4<sup>th</sup> 2022





**ALTO-SHAAM**

Menomonee Falls, WI U.S.A.

Phone 800-558-8744 | +1-262-251-3800 | [alto-shaam.com](http://alto-shaam.com)